

General Specifications

MODEL UT320 Digital Indicating Controller



GS 5D1D11-01E

General

Model UT320 Digital Indicating Controller is a highly accurate 1/8 DIN controller, provided with universal input/output. It has a large display for readings and excellent monitoring operability with the Auto/Man switching key. In addition, heating/cooling control, including PID control with auto-tuning, and the "SUPER" overshoot suppression function are available as control functions, and a retransmission of variables or a loop power supply for a transmitter are also included as standard. As described above, the UT320 is a controller provided with higher functions and capability than conventional similar-size controllers.

Main Features

- The latest in large digital displays has been realized and a large PV display with characters 14 mm in height has been employed to be clearly readable from distant locations.
- Universal input and output enable users to set or change freely the type of measured inputs (thermocouple, RTD or DCV), measurement range, type of control output (4 to 20 mA current, voltage pulse, or relay contact), etc from the front panel.

Function Block Diagram

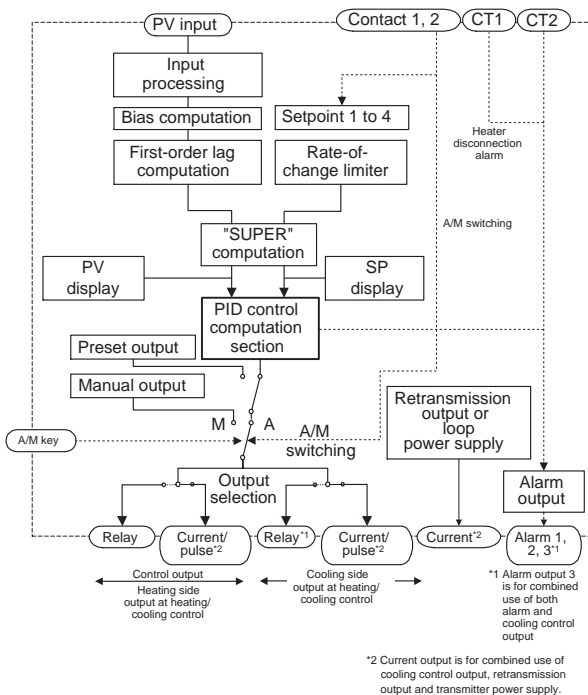

UT320



Function Specifications

Control Computation Functions

Control computation:

Can be selected from the following types:
Continuous PID control, Time-proportional PID control, Heating/Cooling control, ON/OFF control, or Manual reset control (PD control)

Control cycle time: 250 ms

Number of sets of target setpoints and PID parameters: 4

Target setpoint and PID selection:

PID parameters are provided for every target setpoint and the set of PID parameters are selected at the same time that the setpoint number is selected.

Zone PID selection:

PID parameters are selected depending on the value of the PV. For selection, the reference point (PID parameter selection setpoint) or the reference deviation is used.

Reference point method:

The measuring range is divided into a maximum of three zones with up to two reference points, and PID parameters are selected (No. 1 PID to No. 3 PID) for every zone.

Reference point = $EU(0\%) \leq$ Reference point 1 \leq

Reference point 2 \leq EU(100%)

Reference point hysteresis = Fixed to 0.5% of the measured input range width.

Reference deviation method:

PID parameters (No. 4 PID) are selected when the deviation exceeds the reference deviation. This process takes precedence over the reference point method.

Reference deviation = OFF or 0.1 to 100.0% of measured input range width

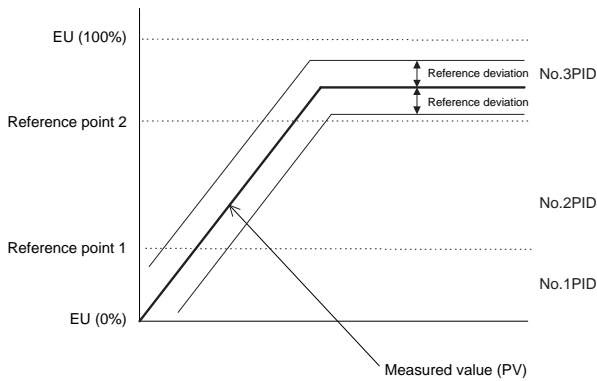
**Auto-tuning:**

Available as standard. If auto-tuning is operated, PID parameters are automatically set (limit cycle method).

“SUPER” function:

Overshoots generated by abrupt changes in the target setpoint or by disturbances can be suppressed.

Control Parameters Setting Range

Proportional band = 0.1 to 999.9%

0.0 to 999.9% (for heating/cooling control)

Integral time = 1 to 6,000 s, or OFF (manual reset)

Derivative time = 1 to 6,000 s, or OFF

Manual reset value = -5.0 to 105.0% of output value
(functions when integral time is off.)

ON/OFF control hysteresis = 0.0 to 100.0% of measured input range width (0.1 to 0.5% for heating/cooling control)

Setpoint rate-of-change setting = off, or 0.0 to 100.0%/h or min of measured input range width

A PV tracking function operates automatically when the setpoint is changed, the power is turned on, or the mode is changed from manual to automatic.

Direct/reverse action:

The output increase/decrease direction can be defined corresponding to a positive or negative deviation.

For heating/cooling control, it is fixed; for the heating side output, reverse, for the cooling side output, direct.

Anti-reset windup:

When controller output is limited, normal integration is superseded by an anti-reset windup computation to suppress over-integration.

Control output cycle time = 1 to 1000 s (the cooling side output cycle time is also the same when heating/cooling control is used).

Preset output value = -5.0 to 105.0% of output value

Output tracking: Whether the output bump is provided or not can be selected by changing the PID control mode.

Output limiter

Upper limit = Lower limit to 105.0% of output value

Lower limit = -5.0% of output value to upper limit

Heating/cooling dead band = -100.0 to 50.0% for output value

Signal Computation Functions**Measured input computation:**

Bias addition (-100.0 to 100.0% of measured input range width), and first-order lag filter (time constant off or 1 to 120 s)

Contact input function:

Target setpoint selection, Auto/Man operating mode switching, key lock parameter display/non-display switching

Target setpoint selection can be done for either a 2-setpoint or 4-setpoint selection.

- If the 2-setpoint selection is set, Auto/Man mode switching can be used as well.

- If the 4-setpoint selection is set, Auto/Man switching and key lock parameter display/non-display switching cannot be used together.

If key lock parameter display/non-display switching is used, target setpoint selection and Auto/Man mode switching cannot be used.

Alarm Functions

Eighteen types of alarm functions are provided. The alarm status is indicated by the alarm lamp on the front panel.

Also, three points among them can be output as relay contact outputs.

Alarm types:

PV high limit, PV low limit, Deviation high limit, Deviation low limit, Deenergized on deviation high limit, Deenergized deviation low limit, Deviation high and low limits, High and low limits within deviation, Deenergized on PV high limit, Deenergized on PV low limit, SP high limit, SP low limit, Output high limit, Output low limit.

Alarm output:

3 points. Any three points can be output as contact outputs among the above alarm. For heating/cooling control, if cooling side output is output as a relay contact, up to two alarm outputs can be used.

Setting ranges for PV, deviation, setpoint and output alarms:

PV/setpoint alarm:

-100.0 to 100.0% of measured input range

Deviation alarm:

-100.0 to 100.0% of measured input range width

Output alarm:

-5.0 to 105.0% of output value

Alarm hysteresis width:

0.0 to 100.0% of measured input range width

Waiting action

Waiting action can be set to make PV/deviation alarm stand-by during start-up or after SP change until SP reaches the normal region.

Heater disconnection alarm (optional):

two circuits incorporated

A heater disconnection alarm is output if the heater current consumption is the disconnection detection value or less. This alarm can be used for ON/OFF control or time-proportional PID control.

Heater current setting range: 0.0 to 50.0 A

Setting accuracy: $\pm 5\% \pm 1$ digit of span

Heater current detecting resolution: 0.5 A

Time required until disconnection detection is on: 0.2 s minimum

Disconnected sensor model: CTL-6-S (URD Co. Ltd.)

Sensor grounding alarm:

An alarm is output after detecting a change in control output. If the moving average * of control output is out of the setting range (between the high and low limits of the on/off rate) in spite of the deviation being within a fixed range (on/off rate detection width) and control being in stable condition, the sensor is judged to be in a grounding condition.

* Moving average refers to the average value for output values sampled (five times) in every cycle time.

High- and low-limit setting range of on/off rate: -5.0 to 105.0% of output range

Detection width of on/off rate: 0.0 to 100.0% of measured input range width.

Fault diagnostic alarm:

Input burnout, A/D conversion error, thermocouple reference junction compensation error

FAIL output: Software failure and/or hardware failure
When in Fail, control output, retransmission output and alarm output become 0% or off.

Display and Operation Function

PV display: In 4-digit digital display of engineering unit

Setpoint display: Various data, such as the setpoint (SP), are displayed by selection on the 4-digit digital display.

Status indicating lamps:

3 alarm indicator lamps: AL1, AL2, AL3

3 setpoint number indicator lamps:

SP2, SP3, SP4 (Go out when SP1 is selected.)

MAN operation mode lamp: MAN (lit in MAN mode)

Operation keys:

△ and ▽ keys:

Increases or decreases setpoints and various parameters.

SET/ENT key:

For data setting or call-up/selection of various parameters

A/M key: Switching of operation mode (Auto/Man)

Status lamps

Alarm (AL1, 2, 3), Manual (MAN).
Setpoint No (SP2, 3, 4), in use.

Operational keys

Increase/Decrease the setting data (,)
Select parameter/Enter the setting data (SET/ENT)
A/M mode switching (A/M)



LED display unit (for PV)
Display PV, and error code when error is detected.

LED display unit (for SP)
Display setpoint (SP), output value, and setting item/value of parameters.

Examples of Communication System Configuration Diagram

(1) Computer link communication

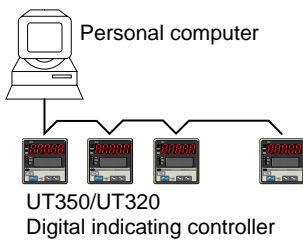

(2) Ladder communication

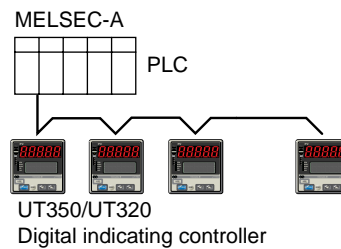

(3) Coordinated operation

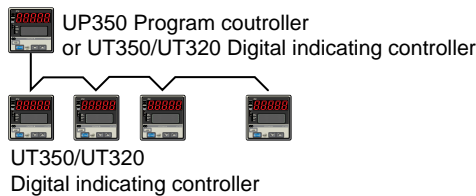

SELECT display:

A panel where operating parameters that are frequently changed during operation can be selected and registered. For example, by registering the first alarm setpoint in the SELECT display, the setpoint can easily be changed during operation.

Security function:

An operation-inhibiting mode using a password is provided.

■ Communication Specifications (optional)

This controller has a communication function and can be connected to a personal computer programmable logic controllers, or other UT320 controllers.

Communication protocol

Computer link communication:

Communication protocol with a personal computer.

Ladder communication:

Communication protocol with programmable logic controller made.

Coordinated operation:

Communication protocol to coordinate operation with two or more GREEN series controllers. The UT320 can be connected as a master station or a slave station.

Communication interface

Communication protocol:

Computer link or ladder communication

Standards: EIA RS485

Communication protocol:

Computer link or ladder or coordinated operation

Maximum number of connectable controllers:

31 GREEN series controllers

Maximum communication distance: 1,200 m

Communication method:

Two-wire half duplex or four-wire half duplex, start-stop synchronization, non-procedural

Communication rate:

600, 1200, 2400, 4800, 9600 bps

Input Type		Input range code	Instrument range (°C)	Instrument range (°F)	Measurement accuracy*1
Thermocouple	K	1	-200 to 1370°C	-300 to 2500°F	At or above 0°C ±0.1% ±1 digit of F.S. Below 0°C, ±0.2% ±1 digit of F.S.
		2	-199.9 to 999.9°C	0 to 2300°F	
		3	-199.9 to 500.0°C	-199.9 to 999.9°F	
	J	4	-199.9 to 999.9°C	-300 to 2300°F	
	T	5	-199.9 to 400.0°C	-300 to 750°F	
		6	0.0 to 400.0°C	-199.9 to 750.0°F	
	B	7	0 to 1800°C	32 to 3300°F	At or above 400°C ±0.15% ±1 digit of F.S. Below 400°C ±5% ±1 digit of F.S.
	S	8	0 to 1700°C	32 to 3100°F	±0.15% ±1 digit of F.S.
	R	9	0 to 1700°C	32 to 3100°F	
	N	10	-200 to 1300°C	-300 to 2400°F	±0.1% ±1 digit of F.S.
	E	11	-199.9 to 999.9°C	-300 to 1800°F	
	L (DIN)	12	-199.9 to 900.0°C	-300 to 1300°F	At or above 0°C ±0.1% ±1 digit of F.S. Below 0°C ±0.2% ±1 digit of F.S.
		U (DIN)	13	-199.9 to 400.0°C	
			14	0.0 to 400.0°C	-199.9 to 750.0°F
W (DIN)	15	0 to 2300°C	32 to 4200°F	±0.2% ±1 digit of F.S.	
Platinel 2	16	0 to 1390°C	32 to 2500°F	±0.1% ±1 digit of F.S.	
PR20-40	17	0 to 1900°C	32 to 3400°F	At or above 800°C ±0.5% ±1 digit of F.S. Below 800°C, not guaranteed	
W97Re3-W75Re25	18	0 to 2000°C	32 to 3600°F	±0.2% ±1 digit of F.S.	
RTD	Jpt100	30	-199.9 to 500.0°C	-199.9 to 999.9°F	±0.1% ±1 digit of F.S.
		31	-150.0 to 150.0°C	-199.9 to 300.0°F	±0.2% ±1 digit of F.S.
	Pt100	35	-199.9 to 640.0°C	-300 to 1180°F	±0.1% ±1 digit of F.S.
		36	-199.9 to 500.0°C	-199.9 to 999.9°F	
		37	-150.0 to 150.0°C	-199.9 to 300.0°F	±0.2% ±1 digit of F.S.
Standard signal	0.4 to 2V	40	0.400 to 2.000	Scaling is enable in the following 4 range. -1999 to 9999 -199.9 to 999.9 -19.99 to 999.9 -1.999 to 9.999	±0.1% ±1 digit of F.S.
	1 to 5V	41	1.000 to 5.000		
DC voltage	0 to 2V	50	0.000 to 2.000		
	0 to 10V	51	0.00 to 10.00		
	-10 to 20mV	55	-10.00 to 20.00		
	0 to 100mV	56	0.0 to 100.0		

*1 Performance in the standard operating conditions (at 23±2°C, 55±10% RH, and 50/60 Hz power frequency)

■ Hardware Specifications

Measured Input Signal

Number of input points: 1

Input system:

The types of input/measurement ranges can be set using software from a list of inputs.

Input type, measurement ranges and measurement accuracy:

Refer to the table below.

Burnout detection:

Functions with a thermocouple (TC), RTD, standard signal 0.4 to 2 V, and 1 to 5 V.
Can be specified as upscale, downscale, and off.
For standard signal, judged as burnout at 0.1 V or less.

Input bias current: 0.05 μ A (for TC/RTD)

Input resistance:

1 M Ω or more for TC/mV
About 1 M Ω for DC voltage input

Allowable signal source resistance:

250 Ω or less; effect of permissible signal source resistance 0.1 μ V/ Ω or less for TC/mV
2 k Ω or less; effect of permissible signal source resistance 0.01%/100 Ω or less for DC voltage

Allowable leadwire resistance:

Max. of 150 Ω /wire (resistance in each of three wires must be equal) for RTD
However, 10 Ω /wire in the range of -150.0 to 150.0 $^{\circ}$ C.

Allowable input voltage:

\pm 10 V DC for TC/mV/RTD
 \pm 20 V DC for DC voltage

Noise rejection ratio:

Normal mode 40 dB (50/60 Hz) or more
Common mode 120 dB (50/60 Hz) or more

Reference-junction compensation error:

\pm 1.0 $^{\circ}$ C (15 to 35 $^{\circ}$ C),
 \pm 1.5 $^{\circ}$ C (0 to 15 $^{\circ}$ C, 35 to 50 $^{\circ}$ C)

Applicable standards: JIS, IEC, or DIN for TC and RTD

Loop Power Supply for Sensor

The controller supplies power to a two-wire transmitter. Place a 100 Ω resistor between the controller and the transmitter, convert a current signal to a voltage signal, and read it from the PV input. Either the retransmission output or the loop power supply can be used.

Supply voltage is 14.5 to 18.0 V DC. Maximum supply current is about 21 mA (with a protection circuit for a field short-circuit).

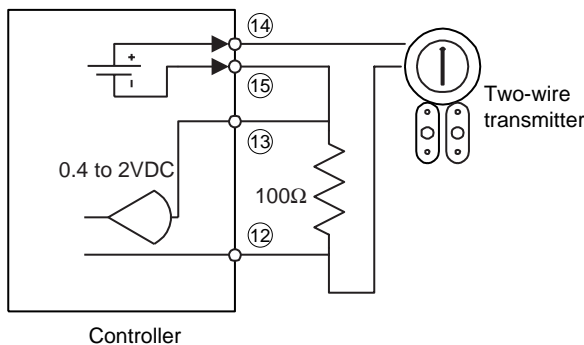

Retransmission Output

Either PV, target setpoint, or control output is output. Either the retransmission output or the loop power supply can be used.

Number of output points: 1

Output signal: 4 to 20 mA DC

Load resistance: 600 Ω or less

Output accuracy: \pm 0.3% of span

* Performance in the standard operating conditions (at 23 \pm 2 $^{\circ}$ C, 55 \pm 10% RH, and 50/60 Hz power frequency)

Control Outputs

The control output is of a universal scheme and can be selected from the following types of outputs. In the case of heating/cooling control, it is also selectable from these outputs. However, if the cooling side output is a relay contact output, the third alarm cannot be used and similarly, if the cooling side output is a voltage pulse or current output, the retransmission output/loop power supply cannot be used.

Current output

Number of output points: 1

Output signal: 4 to 20 mA

Load resistance: 600 Ω or less

Output accuracy: \pm 0.3% of span

Performance in the standard operating conditions (at 23 \pm 2 $^{\circ}$ C, 55 \pm 10% RH, and 50/60 Hz power frequency)

Voltage pulse output

Number of output points: 1

Output signal:

On voltage = 12 V DC (load resistance of 600 Ω or more; current on short-circuiting about 30 mA)

Off voltage = 0.1 V DC or less

Resolution: 10 ms

Relay contact output

Number of output points: 1

Output signal:

Three terminals for NC, NO, and Common transfer-contacts

Contact rating:

250 V AC, 3 A or 30 V DC, 3 A (resistive load)

Resolution: 10 ms

Contact Inputs

Usage:

Target setpoint selection, Auto/Man mode switching, or Key lock parameter display/non-display switching

Number of input points: 2

Input type: Non-voltage contact input or transistor open collector input

Input contact rating: 12 V DC, 10 mA or more

On/off determination:

For contact input,

ON= contact resistance of 1 k Ω or less,

OFF= contact resistance of 20 k Ω or more.

For transistor contact input,

ON= 2 V or less,

OFF= leakage current of 100 μ A or less.

Minimum retention time for status detection: 0.4 s

Contact Outputs

Usage: Alarm output and FAIL output
 Number of relay contact output points: 3
 Relay contact rating: 240 V AC, 1 A or 30 V DC, 1 A

Display Specifications

PV display:
 4-digit, 7-segment red LED; character height - 12 mm
 Setpoint display:
 4-digit, 7-segment red LED; character height - 9.3 mm
 Status indicating lamps: LEDS

Conformance to Safety and EMC Standards

Safety:
 Conforms to IEC1010-1: 1990 and EN61010-1: 1992. Certified for CSA1010. The overvoltage category of each input is CAT II (IEC1010-1)
 Certified for UL508.
 EMC standards:
 Conforms to the following standards.
 During test, the controller continues to operate with the measurement accuracy within $\pm 20\%$ of the range.
 EN55011: Class A Group 1 for EMI (emissions)
 EN50082-2: 1995 for EMS (immunity)

Construction, Mounting, and Wiring

Construction: Dust-proof and Water-proof front panel conforming to IP55.
 Material: ABS resin and polycarbonate
 Case color: Black
 Weight: Approx. 1 kg or less
 External dimensions:
 48 (width) \times 96 (height) \times 100 (depth) mm
 Mounting: Direct panel mounting; mounting bracket, one each for upper and lower mounting
 Panel cutout dimensions: $45^{+0.6}_0$ (width) \times $92^{+0.8}_0$ (height) mm
 Mounting attitude:
 Up to 30 degrees above the horizontal. No downward tilting allowed.
 Wiring:
 M3.5 (ISO 3.5 mm) screw terminals (signal wiring and power/ground wiring as well)

Power Supply Specifications and Isolation

Power supply: Rated at 100 to 240 V AC ($\pm 10\%$), 50/60 Hz
 Power consumption: MAX. 20 VA (MAX. 8.0W)
 Memory back-up: Non-volatile memory.
 Withstanding voltage:
 2300 V AC for 1 minute between primary and secondary terminals
 2300 V AC for 1 minute between primary and ground terminals
 1500 V AC for 1 minute between ground and secondary terminals.
 500V AC for 1minute between two secondary terminals

(Primary terminals = Power and relay output terminals)
 (Secondary terminals = Analog I/O signal terminals, voltage pulse output terminals, contact input terminals)

Isolation resistance:
 20 M Ω or more when 500 V DC voltage is applied between the power terminals and ground terminal.

Grounding:
 Class 3 grounding (grounding resistance of 100 Ω or less)

Isolation specifications
 Measured input terminal:
 Isolated from other I/O terminals. Not isolated from internal circuits.
 Loop power supply terminals:
 Not isolated from 4 to 20 mA analog output (voltage pulse control circuit). Isolated from other I/O terminals and internal circuits.
 Analog 4 to 20 mA output (control, retransmission) terminal:
 Not isolated from another 4 to 20 mA output terminals each other, loop power supply terminals, and voltage pulse control output terminal. Isolated from other I/O terminals and internal circuits.

Voltage pulse control output terminal:
 Not isolated from 4 to 20 mA output and loop power supply. Isolated from other I/O terminals and internal circuits.

Relay contact control output terminals:
 Isolated from other contact output terminals, other I/O terminals and internal circuits.

Contact input terminals:
 Not isolated from other contact input terminals, and communication terminals.
 Isolated from other I/O terminals and internal circuits.

Relay contact output terminals:
 Not isolated from other relay contact output terminals. Isolated from other I/O terminals and internal circuits.

RS-485 communication terminals:
 Not isolated from contact input terminals. Isolated from other I/O terminals and internal circuits.

Power terminals:
 Isolated from other I/O terminals, ground terminal, and internal circuits.

Ground terminal:
 Isolated from other I/O terminals, power terminals, and internal circuits.

Environmental Conditions

Normal operating conditions:
 Ambient temperature: 0 to 50°C (40°C or less for mounting of instruments side-by-side)
 Ambient humidity: 20 to 90% RH (no condensing)
 Magnetic field: 400 AT/m or less
 Continuous vibration (5 to 14 Hz):
 Peak-to-peak amplitude of 1.2 mm or less
 Continuous vibration (14 to 150 Hz):
 4.9 m/s² (0.5G) or less
 Short-period vibration: 14.7 m/s² (1.5G) or less, 15 s
 Shock: 147 m/s² (15G) or less, 11 ms
 Installation altitude: 2,000 m or less above sea level
 Warm-up time 30 minutes or more
 Transportation and storage conditions:
 Temperature: -25 to 70°C
 Humidity: 5 to 95% RH

Effect of operating conditions
 Effect of ambient temperature:
 For voltage or TC inputs:
 Whichever is greater, $\pm 1 \mu\text{V}/^\circ\text{C}$ or $\pm 0.01\%$ of F.S./ $^\circ\text{C}$
 For RTD inputs:
 $\pm 0.05^\circ\text{C}/^\circ\text{C}$ (ambient temperature) or less for RTD input
 $\pm 0.05\%$ of F.S./ $^\circ\text{C}$
 For analog output:
 $\pm 0.05\%$ of F.S./ $^\circ\text{C}$ or less
 Effect of power supply fluctuation (within rated voltage range):
 For analog input:
 Equal to or less than whichever is greater, $\pm 1 \mu\text{V}/10 \text{ V}$ or $\pm 0.01\%$ of F.S./10 V
 For analog output: $\pm 0.05\%$ of F.S./10 V or less

Terminal Arrangements

Terminal number	Symbol	Signal Description
1	OUTPUT1	Control output or heating side control output (relay contact) NC
2		Control output or heating side control output (relay contact) NO
3		Control output or heating side control output (relay contact) COM
4	ALM	Alarm contact output 3 or cooling side control output, relay output
5		Alarm contact output 2 (realy output)
6		Alarm contact output 1 (realy output)
7		Alarm contact output, Common (output terminals 4, 5, and 6)
8	SUPPLY	Power supply L
9		Power supply N
10		Ground
11	INPUT	Measured input terminal, A (RTD)
12		Measured input terminal + (TC, mV ,V), b (RTD)
13		Measured input terminal - (TC, mV ,V), B (RTD)
14	OUTPUT2/RET	Retransmission output or loop power supply/cooling side control output (current/voltage pulse) +
15		Retransmission output or loop power supply/cooling side control output (current/voltage pulse) -
16	OUTPUT1	Control output or heating side control output (current/voltage pulse) +
17		Control output or heating side control output (current/voltage pulse) -
18	DI	External contact input2
19		External contact input1
20		External contact input, common (input terminals 18, 19)
21	/	Unused terminal
22		Unused terminal
23	RS485*1	RS485 communication SDB (+)
24		RS485 communication SDA (-)
25		RS485 communication RDB (+)
26		RS485 communication RDA (-)
27		RS485 communication SG
28	CT*2	Heater disconnection detector CT2
29		Heater disconnection detector CT1
30		Heater disconnection detector COM

*1 Available when model code is UT320-□1.
 *2 Available when model code is UT320-□1, UT320-□2.

Terminal Diagram

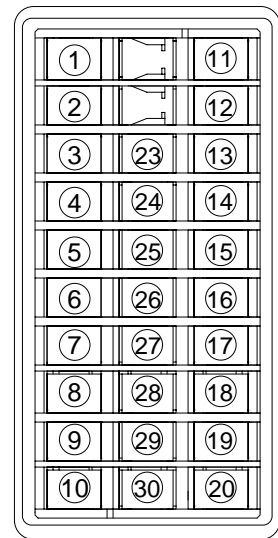

External Dimensions

1. General mounting

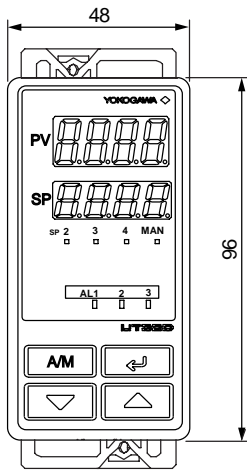
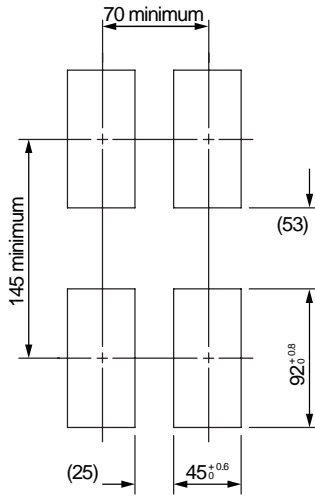

2. Close mounting side-by-side

Unit: mm

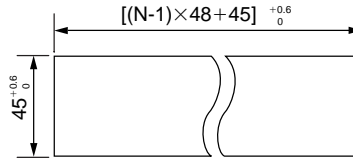

N shows the number of mounted instruments. However, if $N \geq 5$, this dimension depends on the actual measurement.

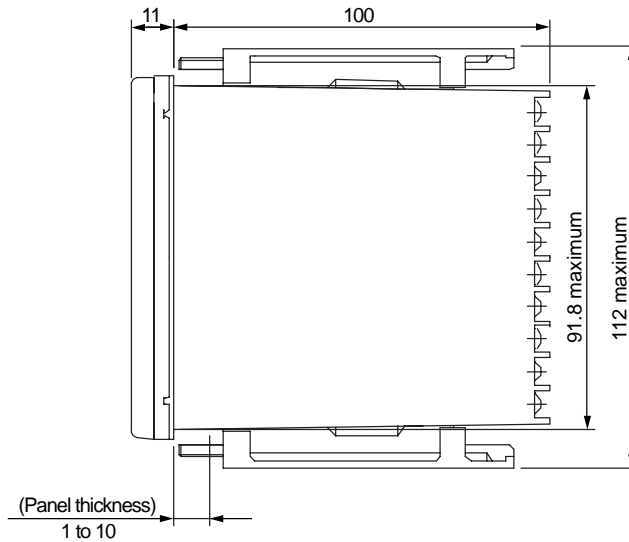
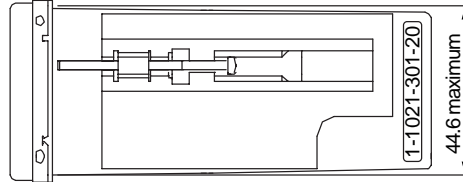

Model and Suffix codes

Model	Suffix Code	Description
UT320		Digital indicating controller (with Retransmission output/loop power supply)
Type	-0	General-purpose type (with universal input/output)
	-2	Heating/cooling type (with universal input/output)
Optional functions	0	None
	1	With communication and heater disconnection alarm
	2	With heater disconnection alarm

Standard accessories: instruction manual, mounting bracket, and unit label.

Items to be specified when ordering

Model and suffix codes