

---

Instruction  
Manual

**UT150, UT152, UT155**  
**Temperature Controllers**

IM 5C1E11-41E

---



# 1. NOTICE

---

The following safety symbol is used both on the product and in this instruction manual.

---



This symbol stands for “Handle with Care.” When displayed on the product, the operator should refer to the corresponding explanation given in the instruction manual in order to avoid injury or death of personnel and/or damage to the product. In the manual the symbol is accompanied by an explanation of the special care that is required to avoid shock or other dangers that may result in injury or loss of life.

---

The following symbols are used in this manual only.



## **IMPORTANT**

---

Indicates that operating the hardware or software in a particular manner may lead to damage or result in system failure.

---



## **NOTE**

---

Draws attention to information that is essential for understanding the operation and/or features of the product.

---

## 2. WHAT IS ON THE FRONT PANEL?

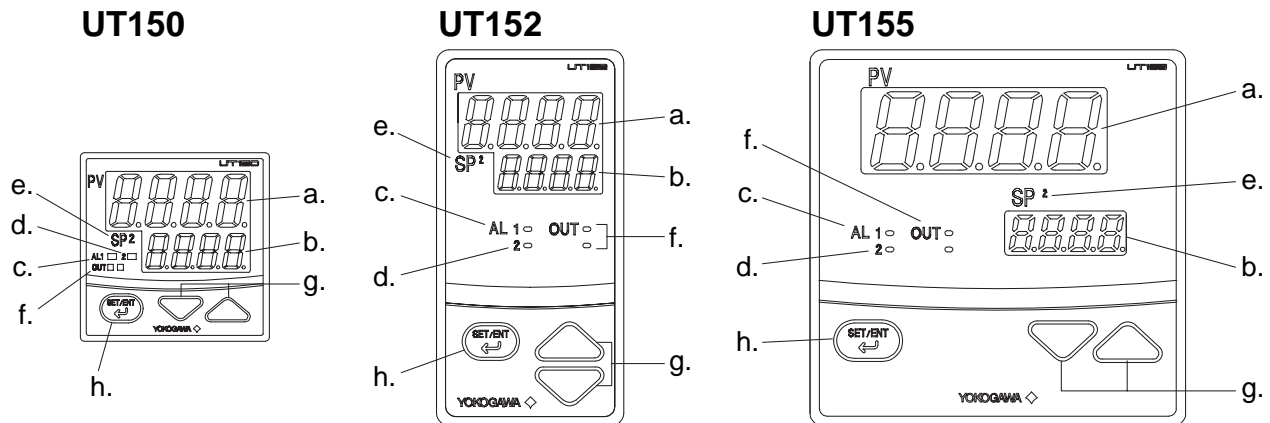

|    | Name  | Function  |
|----|---|---|
| a. | PV display (red)  | Indicates PV (measured value) and character information such as parameter codes and error codes.  |
| b. | SP display (green)  | Indicates SP (target setpoint) and parameter values.  |
| c. | Alarm 1 (AL1) lamp (red)  | Lit when alarm 1 is activated.  |
| d. | Alarm 2 (AL2) lamp (red)  | Lit when alarm 2 is activated.  |
| e. | SP2 lamp (green)  | Lit when SP2 is being used for control operation.   |
| f. | Output (OUT) display lamps<br>UT150: (Left: orange; right: green)<br>UT152, UT155:<br>(Upper: orange; lower: green) | Lit while control output is being output. <ul style="list-style-type: none"> <li>The left (upper) lamp is lit in orange during general control output.</li> <li>In heating/cooling control, the left (upper) lamp lights up in orange when the heating-side output is active; while the right (lower) lamp lights up in green when the cooling-side output is active.</li> </ul>  |
| g. | Data change keys<br>(Indicated as simply the ▽ and ▴ keys hereafter.)   | <ul style="list-style-type: none"> <li>Changes SP and the parameter values.</li> <li>Pressing the ▽ key decreases the data value and pressing the ▴ key increases it. Holding down the key will gradually increase the speed of the change.</li> </ul>  |
| h. | SET/ENT key (data registering key)<br>(Indicated as simply the SET/ENT key hereafter.)                              | <ul style="list-style-type: none"> <li>Registers the data value changed using the data change keys.</li> <li>Switches between parameter setting displays sequentially.</li> <li>Pressing the key for 3 seconds or longer in the operation display retrieves the operation parameter setting display.</li> <li>Pressing the key for 3 seconds or longer in either an operation or setup parameter setting display transfers back to operation display 1. (See Page 13.)</li> </ul> |

# 3. INSTALLING THE CONTROLLER



## WARNING

To prevent electrical shock, the source of power to the controller must be turned off when mounting the controller on to a panel.



## CAUTION

To install the controller, select a location where:

1. No-one may accidentally touch the terminals;
2. Mechanical vibrations are minimal;
3. Corrosive gas is minimal;
4. The temperature can be maintained at about 23°C with minimal fluctuation;
5. There is no direct heat radiation;
6. There are no resulting magnetic disturbances;
7. The terminal board (reference junction compensation element, etc.) is protected from wind;
8. There is no splashing of water; and
9. There are no flammable materials.

### Never place the controller directly on flammable items.

If the controller has to be installed close to flammable items or equipment, be sure to enclose the controller in shielding panels positioned at least 150mm away from each side. These panels should be made of either 1.43mm thick metal-plated steel plates or 1.6mm thick uncoated steel plates.

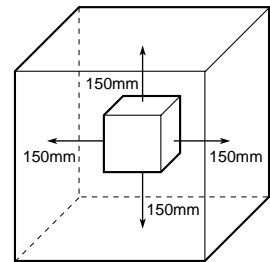

- Mount the controller at an angle within 30° from horizontal with the screen facing upward. Do not mount it facing downward.

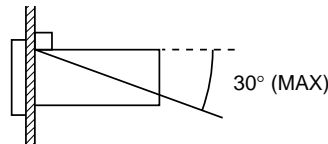

## ■ Mounting the Controller

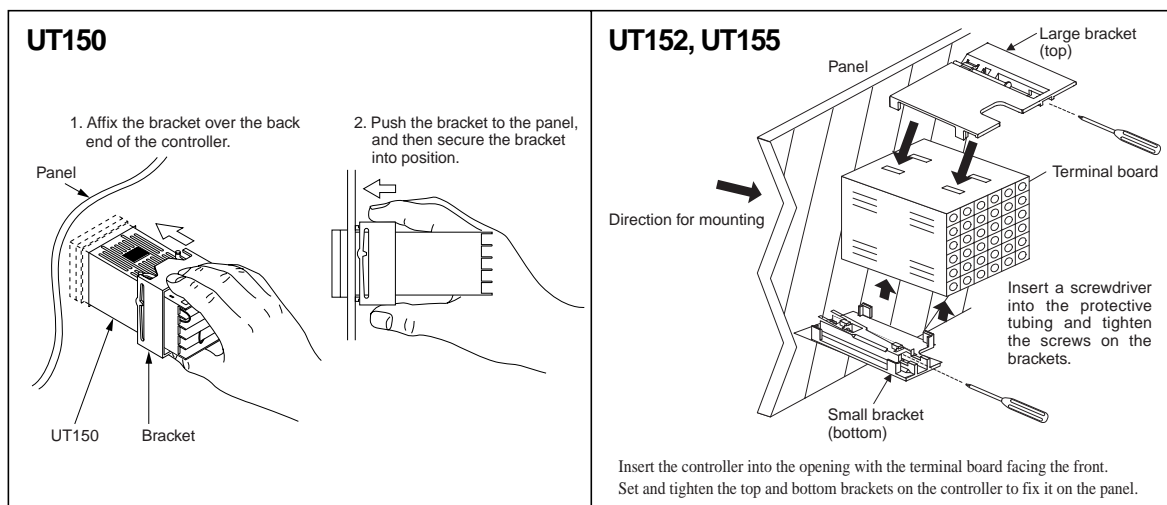

# 4. PANEL CUTOUT DIMENSIONS AND EXTERNAL DIMENSIONS



## NOTE

Splash-proof construction is not available when the side-by-side close mounting method shown in the following figures, is chosen for any of the controllers.

### 1. General Mounting

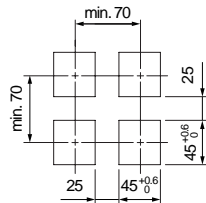

**UT150**

Unit: mm

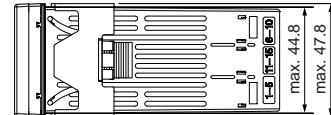

### 2. Side-by-side Close Mounting

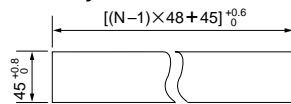

N is the number of controllers.  
If  $N \geq 5$ , then measure the actual length.

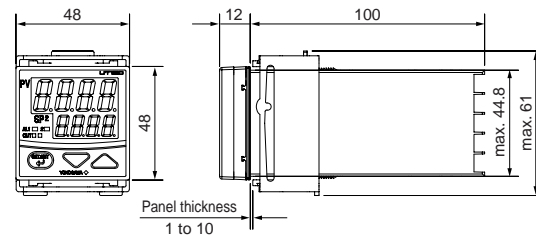

### 1. General Mounting

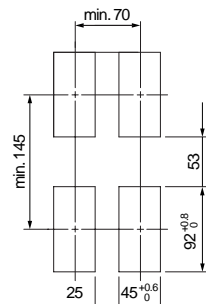

**UT152**

Unit: mm

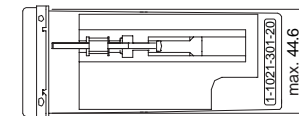

### 2. Side-by-side Close Mounting

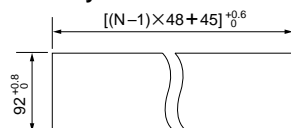

N is the number of controllers.  
If  $N \geq 5$ , then measure the actual length.

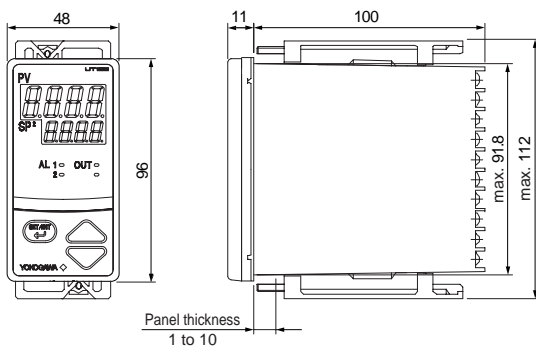

### 1. General Mounting

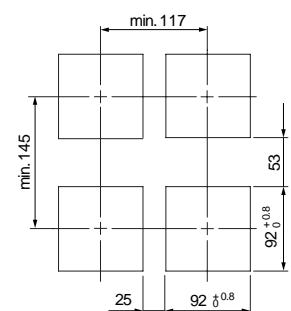

**UT155**

Unit: mm

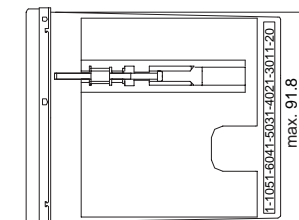

### 2. Side-by-side Close Mounting

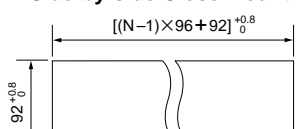

N is the number of controllers.  
If  $N \geq 5$ , then measure the actual length.

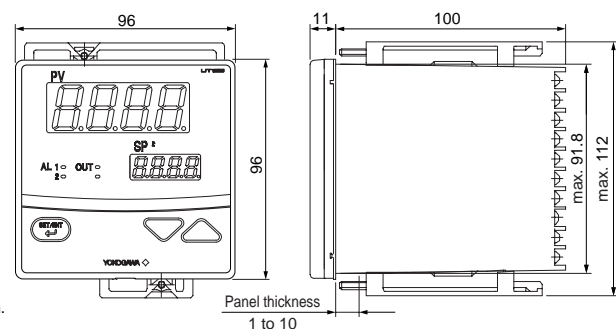

# 5. WIRING



## WARNING

- 1) Before you start wiring, turn off the power source and use a tester to check that the controller and cables are not receiving any power in order to prevent electrical shock.
- 2) Wiring should be carried out by personnel with appropriate electrical knowledge and experience.



## IMPORTANT

- 1) Use a single-phase power source. If the source has a lot of noise, use an isolation transformer for the primary side and a line filter (we recommend TDK's ZAC2205-00U product) for the secondary side. When this noise-prevention measure is taken, keep the primary and secondary power cables well apart. Since the controller has no fuse, be sure to install a circuit breaker switch (of 5A and 100V AC or 220V AC, and that conforms to IEC standards) and clearly indicate that the device is used to de-energize the controller.
- 2) For thermocouple input, use shielded compensating lead wires. For RTD input, use shielded wires which have low resistance and no resistance difference between the 3 wires. See the table given later for the specifications of the cables and terminals and the recommended products.
- 3) The control output relay cannot be replaced even though it has a limited service life (100,000 relay contacts for the resistance load). Thus, an auxiliary relay should be used so that the load can be turned on and off.
- 4) When using an inductive load (L) such as an auxiliary relay and solenoid, be sure to insert a CR filter (for AC) or diode (for DC) in parallel as a spark-rejecting surge suppressor to prevent malfunctions or damage to the relay.



## NOTE

- Always fix a terminal cover bracket to the UT150 controller before wiring if an optional anti-electric-shock terminal cover (part number: L4000FB) is used.
- Two types of optional anti-electric-shock terminal covers (part numbers T9115YE and T9115YD) are available for the UT152 and UT155 controllers, respectively.

## ● Cable Specifications and Recommended Products

|                                       |   |
|---------------------------------------|---|
| Power supply and relay contact output | 600V vinyl insulated wire/cable, JIS C3307, 0.9 to 2.0mm <sup>2</sup> |
| Thermocouple input                    | Shielded compensating lead wire, JIS C1610                            |
| RTD input                             | Shielded wire (3-wire), UL2482 (Hitachi cable)                        |
| Other signals                         | Shielded wire   |

## ● Recommended Terminals

Use M3.5 screw-compatible crimp-on terminals with an insulating sleeve, as shown below.

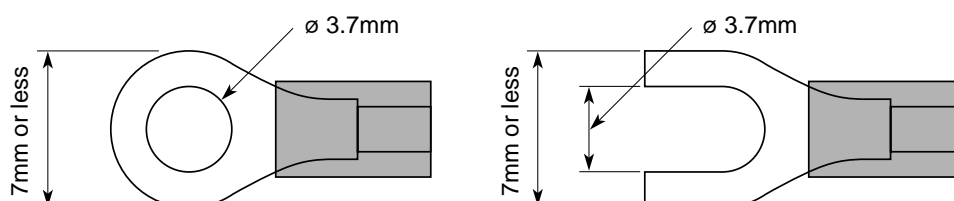

## ■ UT150 Terminal Arrangement (General purpose control model)

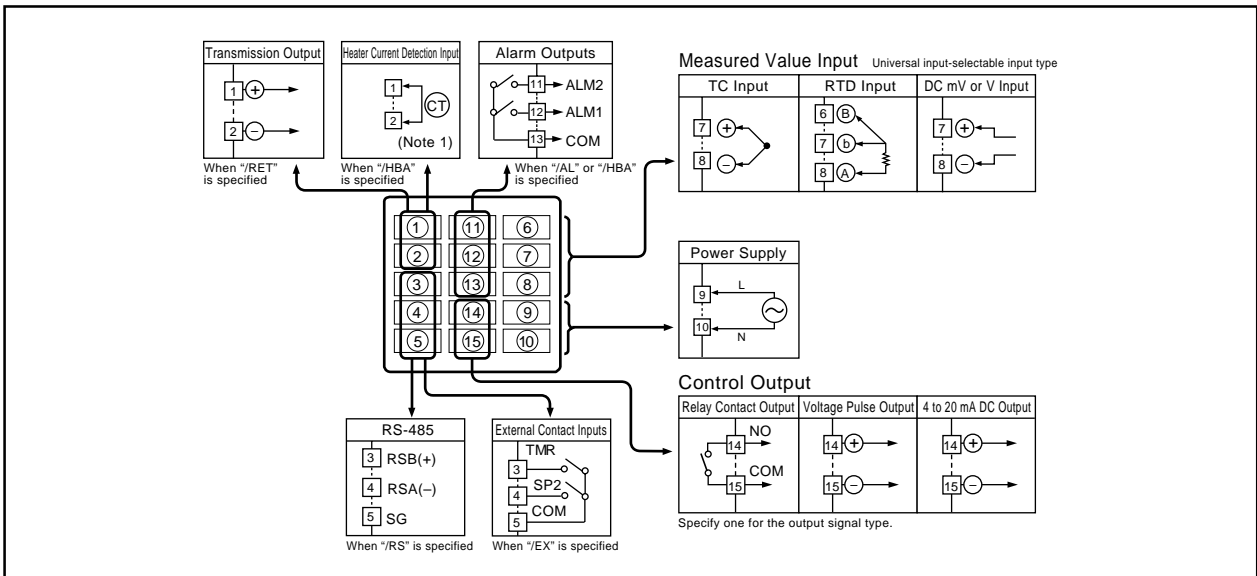

## ■ UT150 Terminal Arrangement (Heating/cooling control model)

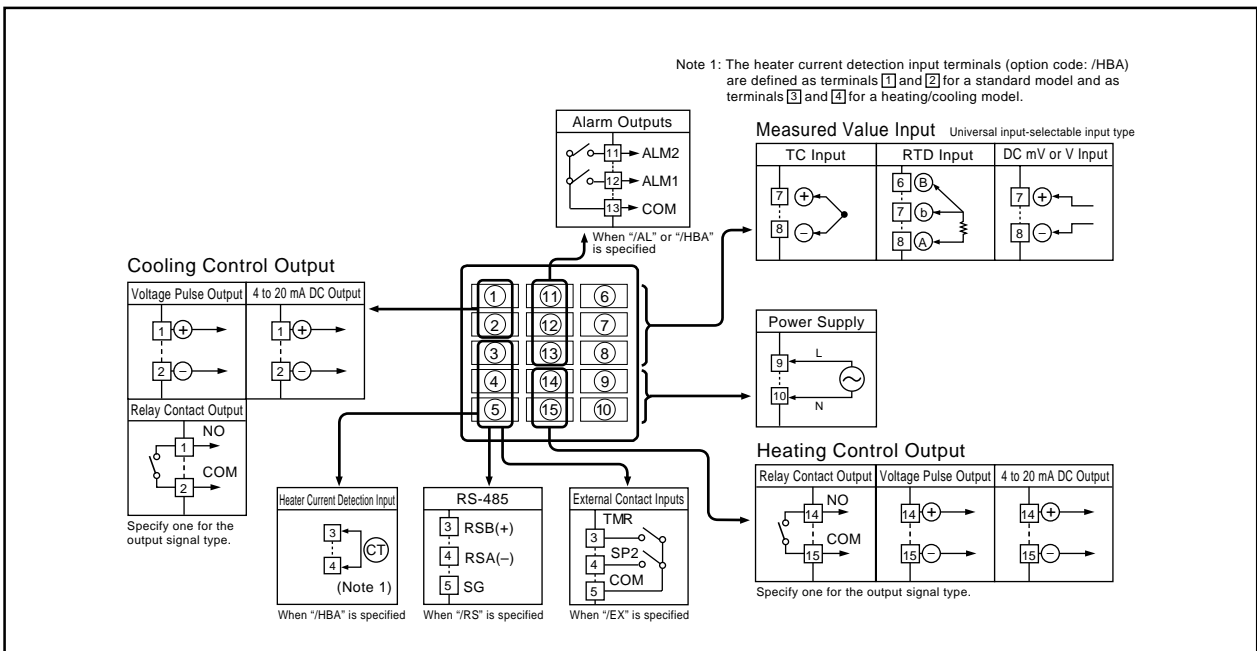

## ■ UT152/UT155 Terminal Arrangement (General purpose control model)

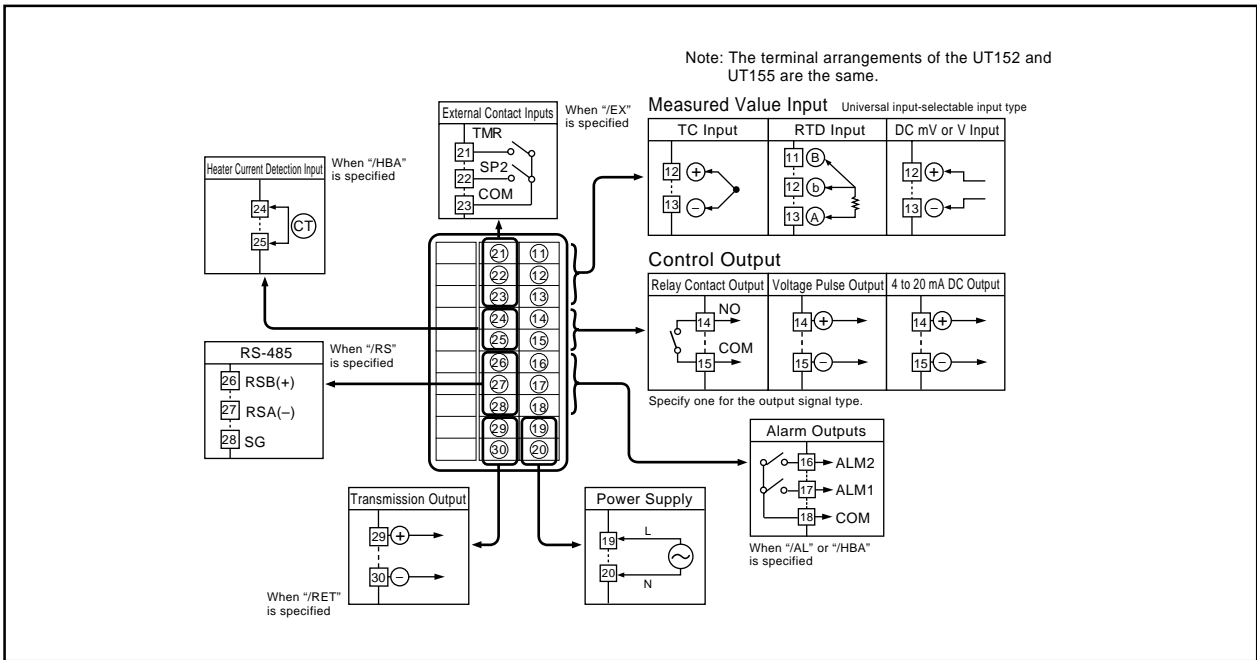

## ■ UT152/UT155 Terminal Arrangement (Heating/cooling control model)

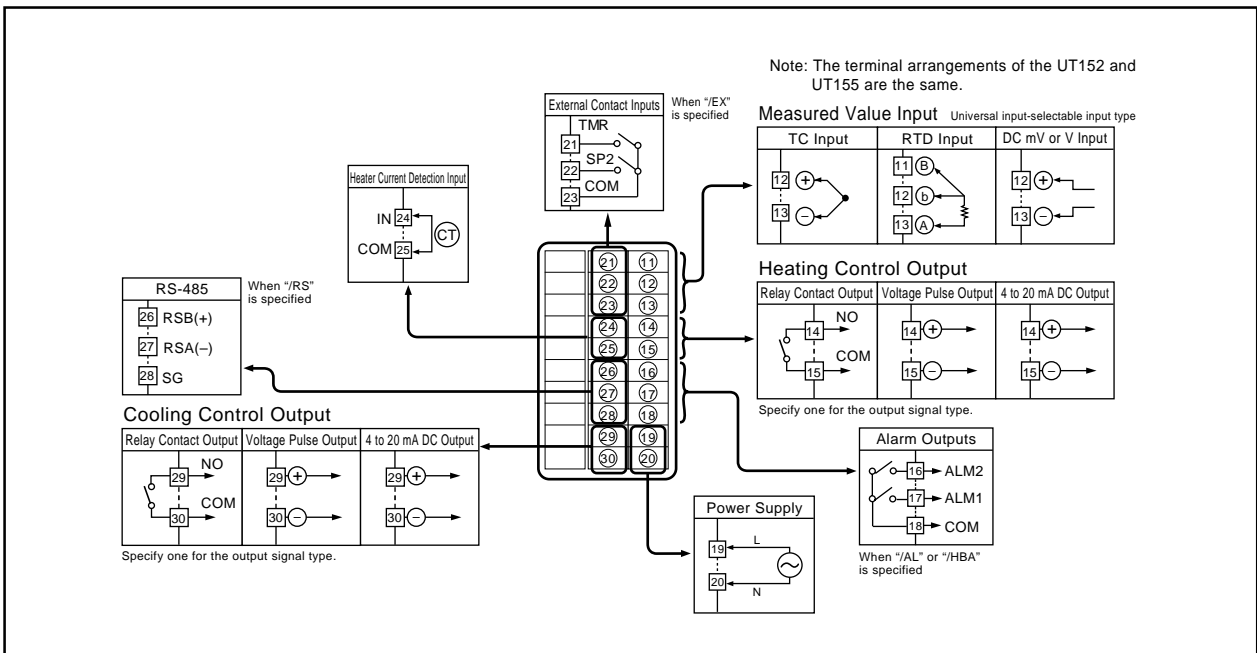

# 6. HARDWARE SPECIFICATIONS

## Measured Value Input

- Input: 1 point
  - Input type: Universal; can be selected by software
  - Input accuracy (at 23 ±2°C ambient temperature)
    - Thermocouple/RTD: ±2°C
  - Voltage (mV, V): ±0.3%
 

However,

    - ±4°C for thermocouple input –200 to –100°C
    - ±3°C for thermocouple input –100 to –0°C
    - ±5°C for type R and S (±9°C for 0 to 500°C)
    - ±9°C for type B (accuracy is not guaranteed for 0 to 400°C)
  - Sampling period for measured value input: 500ms
  - Burn-out detection: Functions for thermocouple or RTD input (burn-out upscale only; cannot be switched off)
  - Input resistance: 1MΩ or greater for thermocouple or DC mV input. Approx. 1MΩ for DC V input
  - Maximum allowable load resistance : 250Ω for thermocouple or DC mV input  
2kΩ for DC V input
  - Maximum allowable wiring resistance for RTD input: 10Ω/wire (The resistance values of three wires must be the same.)
  - Allowable input voltage: ±10V DC for thermocouple or DC mV input  
±20V DC for DC V input
  - Noise rejection ratio: Normal mode noise: Min. 40dB (50/60Hz) Common mode noise: Min. 120dB (Min. 90dB for DC V input)
  - Error of reference junction compensation: ±1.5°C (at 15–35°C)  
±2.0°C (at 0–50°C)
- The reference junction compensation cannot be switched off.
- Applicable standards: Thermocouple and resistance temperature detector JIS/IEC/DIN ITS90

## Control Output

- Output: 1 point (for general-purpose control model) or 2 point (for heating/cooling control model)
- Output type: Choose one from (1) to (3) below:
  - (1) Relay contact output  
Contact capacity: 3A at 240V AC or 3A at 30V DC (with resistance load)  
Note: The control output relay cannot be replaced by users.
  - (2) Voltage pulse output  
On voltage: 12–18V DC  
Off voltage: 0.1V DC or less  $\left\{ \begin{array}{l} \text{load resistance: } 600\Omega \text{ or greater} \\ \text{short-circuit current: approx. } 30\text{mA} \end{array} \right\}$
  - (3) Current output  
Output signal: 4 to 20mA  
Maximum load resistance: 600Ω  
Output accuracy: ±0.3% of span

## Alarm Functions

- **Alarm Functions (Option Code /AL or /HBA)**
  - Alarm types: 22 types (waiting action can be set by software): PV high limit, PV low limit, Deviation high limit, Deviation low limit, Deenergized on deviation high limit, Deenergized on deviation low limit, Deviation high and low limits, High and low limits within deviation, Deenergized on PV high limit, Deenergized on PV low limit, self-diagnostic alarm, failure alarm
  - Alarm output: 2 relay contacts  
Relay contact capacity: 1A at 240V AC or 1A at 30V DC (with resistance load)  
Note: The alarm output relays cannot be replaced by users.
- **Heater Disconnection Alarm (Option Code /HBA)**  
The heater disconnection alarm is available when time-proportional PID control or on/off control is selected.
  - Heater current setting range: 1 to 80A
  - Alarm output: 1 relay contact (The terminals are the same as those of the /AL option.)
  - On time of burn-out detection: Min. 0.2 second
  - Sensor: CTL-6-S or CTL-12-S36-8 (URD Co., Ltd.)  
To be purchased separately.
- **Timer Function (Option Code /EX/AL or /EX/HBA)**  
The output contact status changes when the preset time has passed since external contact (TMR) turned on.  
The contact action can be selected by software from:
  - (1) Make contact—the contact closes upon time-up.
  - (2) Break—the contact opens upon time-up.
  - Input contact type: See **Contact Inputs** below.

## Transmission Output

- The transmission output is provided only when the /RET option is specified, but is not available for the heating/cooling control model.
- Output signal: Measured value in 4–20mA DC
  - Maximum load resistance: 600Ω
  - Output accuracy: ±0.3% of span (at 23±2°C ambient temperature)

## Contact Inputs

- The contact inputs are provided only when the /EX option is specified.
- Functions: (1) Switching over two setpoints (SP1 and SP2)  
(2) Starting a timer (See the **Alarm Functions**.)
  - Input: 2 points (with the shared common terminal)
  - Input type: Voltage-free contact or transistor contact input
  - Contact capacity: At least 12V/10mA
  - On/off judgment: On state for 1kΩ or less; off state for 20kΩ or greater

## Communication Function

The communication function is provided only when the /RS option is specified. (For details, read the instruction manual of the communications function IM 5C1E11-10E.)

- **Communication Protocol**
  - Personal computer link: Used for communication with a personal computer, or UT link module of the FA-M3 controller (from Yokogawa Electric Corporation).
  - Ladder communication: Used for communication with a ladder communication module of the FA-M3, or a programmable controller of other manufacturers.
  - MODBUS communication: Used for communication with equipment featuring the MODBUS protocol.
- **Communication Interface**
  - Applicable standards: Complies with EIA RS-485
  - Number of controllers that can be connected: Up to 31
  - Maximum communication distance: 1,200m
  - Communication method: Two-wire half-duplex, start-stop synchronization, non-procedural
  - Communication speed: 2400, 4800, or 9600 bps

## Safety and EMC Standards

- Safety: Confirms to IEC1010-1: 1990 and EN61010-1: 1992  
Approved by CSA1010 for installation category CAT II (IEC1010-1)  
Certified for UL508 (application pending)
  - EMC standards: Complies with: EN55011: Class A, Group 1 for EMI (emission)  
EN55082-2: 1995 for EMS (immunity)
- The UT150-series temperature controllers conform to the standards specified under the following conditions.
- All wires except those for the power supply and relay contact output terminals are shielded.
  - The controller does not fluctuate more than 20% even when noise is applied.

## Power Supply and Isolation

### Power Supply (Common for All Models)

|                           |   |   |
|---------------------------|---|---|
| Power supply              | Voltage   | Rated at 100–240VAC (±10%) (universal power supply)             |
|                           | Frequency   | 50 or 60Hz  |
| Maximum power consumption |   | 8VA   |
| Memory                    |   | Non-volatile memory   |
| Withstanding voltage      | Between primary terminals and secondary terminals (See note 1.) | 1500V AC for 1 minute (See note 2.)                             |
|                           | Insulation resistance   | Between primary terminals and secondary terminals (See note 1.) |

Note 1: The primary terminals are the power supply terminals and relay output terminals. The secondary terminals are the analog input and output terminals, the voltage pulse output terminals, and the contact input terminals.

Note 2: The withstanding voltage is specified as 2300 V AC per minute to provide a margin of safety.

### Isolation

The bold lines below indicate reinforced isolation, and the broken line indicates functional isolation.

|   |   |
|---|---|
| <ul style="list-style-type: none"> <li>• Power supply terminals</li> </ul>                    | <ul style="list-style-type: none"> <li>• Measured value input terminals</li> <li>• CT input terminals for /HBA</li> <li>• 2 input terminal for /EX</li> <li>• Internal circuit</li> </ul> |
| <ul style="list-style-type: none"> <li>• Control output terminals (relay contacts)</li> </ul> | <ul style="list-style-type: none"> <li>• Control output terminals: Voltage pulse</li> <li>• RS-485 terminals for /RS</li> </ul>   |
| <ul style="list-style-type: none"> <li>• Alarm output terminals (2 relay contacts)</li> </ul> |   |

Note: Neither the measured value input terminals, CT input terminals for the /HBA option, nor input terminals for the /EX option are isolated from the internal circuit.

## Construction, Mounting, and Wiring

- Construction: Splash-proof front panel (compliant with IP65 [Model UT150] and IP55 [Models UT152 and 155]). Splash-proof construction is not available if the controller is mounted closely side-by-side.
- Casing: ABS resin and polycarbonate
- Case color: Black
- Mounting: Flush panel mounting
- Terminals: Screw terminals

## Environmental Conditions

- **Normal Operating Conditions**
  - Warm-up time: At least 30 minutes
  - Ambient temperature: 0–50°C (0–40°C when mounted side-by-side)
  - Rate of change of temperature: 10°C/h or less
  - Ambient humidity: 20–90% RH (no condensation allowed)
  - Magnetic field: 400AT/m or less
  - Continuous vibrations of 5 to 14Hz: Amplitude of 1.2mm or less
  - Continuous vibrations of 14 to 150Hz: 4.9m/s<sup>2</sup> (0.5G) or less
  - Short-period vibrations: 14.7m/s<sup>2</sup> (1.5G) for 15 seconds or less
  - Shock: 147m/s<sup>2</sup> (15G) for 11 milliseconds or less
  - Mounting angle: Upward incline of up to 30 degrees; downward incline is not allowed.
  - Altitude: 2000m or less above sea level
- **Maximum Effects from Operating Conditions**
  - (1) Temperature effects
    - Thermocouple, DC mV and DC V input: ±2μV/°C or ±0.02% of F.S./°C, whichever is the larger
    - Resistance temperature detector: ±0.05°C/°C
    - Analog output: ±0.05% of F.S./°C
  - (2) Effect from fluctuation of power supply voltage (within rated voltage range)
    - Analog input: ±0.2μV/V or ±0.002% of F.S./V, whichever is the large
    - Analog output: ±0.05% of full scale/V
- **Transportation and Storage Conditions**
  - Temperature: –25 to 70°C
  - Humidity: 5 to 95% RH (no condensation allowed)
  - Shock: Package drop height 90cm (when packed in the dedicated package)

# 7. KEY OPERATIONS



## NOTE

At power-on, the temperature controller displays the operation display ①, but if the input range setting remains OFF, then “IN” appears. In this case, press the key to display the input range code you want to use, then press the key to register it. (Refer to the flowchart on page 13.)

- (1) You can move between parameter setting displays using the key.
- (2) To change the set value,
  - (i) Change the display value with the or key (the period flashes).
  - (ii) Press the key to register the setting.

Note: If you cannot change, check the key-lock parameter (LOC) setting.

- (3) At the operation display ① or ②, pressing the key for at least 3 seconds retrieves the operation parameter setting display.
- (4) At the operation parameter setting display, pressing the key for at least 3 seconds transfers back to the operation display ①. Registering the key-lock parameter LOC to “-1” retrieves the setup parameter setting display.
- (5) At the setup parameter setting display, pressing the key for at least 3 seconds transfers back to the operation display ①.

**NOTE**

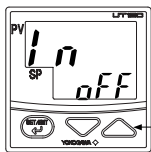

When “In” appears, press the key to display the input range code you want to use, then press the key to register it. After this operation, the controller shows the operation display ①.

### ● UT150/UT152/UT155 Input Ranges

| Input type   | Range (°C)  | Range code (°C)   | Range (°F)    | Range code (°F)   |    |
|--------------|-------------|-------------------|---------------|-------------------|----|
| Thermocouple | K           | -270 to 1370.0°C  | 1             | -300 to 2500°F    | 31 |
|              |             | 0.0 to 600.0°C    | 2             | 32.0 to 999.9°F   | 32 |
|              |             | 0.0 to 400.0°C    | 3             | 32.0 to 750.0°F   | 33 |
|              |             | -199.9 to 200.0°C | 4             | -300 to 400°F     | 34 |
|              | J           | -199.9 to 999.9°C | 5             | -300 to 2100°F    | 35 |
|              | T           | -199.9 to 400.0°C | 6             | -300 to 750°F     | 36 |
|              | E           | -199.9 to 999.9°C | 7             | -300 to 1800°F    | 37 |
|              | R           | 0 to 1700°C       | 8             | 32 to 3100°F      | 38 |
|              | S           | 0 to 1700°C       | 9             | 32 to 3100°F      | 39 |
|              | B           | 0 to 1800°C       | 10            | 32 to 3200°F      | 40 |
|              | N           | -200 to 1300°C    | 11            | -300 to 2400°F    | 41 |
|              | L           | -199.9 to 900.0°C | 12            | -300 to 1600°F    | 42 |
|              | U           | -199.9 to 400.0°C | 13            | -300 to 750°F     | 43 |
| Platinel 2   | 0 to 1390°C | 14                | 32 to 2500°F  | 44                |    |
| RTD          | Pt100       | -199.9 to 850.0°C | 15            | -199.9 to 999.9°F | 45 |
|              |             | 0.0 to 400.0°C    | 16            | 32.0 to 750.0°F   | 46 |
|              |             | -199.9 to 200.0°C | 17            | -300 to 400°F     | 47 |
|              |             | -19.9 to 99.9°C   | 18            | -199.9 to 999.9°F | 48 |
|              | JPt100      | -199.9 to 500.0°C | 19            |                   |    |
| DC voltage   | 0 to 100mV  | 0.0 to 100.0      | User-scalable | 20                |    |
|              | 0 to 5V     | 0.000 to 5.000    |               | 21                |    |
|              | 1 to 5V     | 1.000 to 5.000    |               | 22                |    |
|              | 0 to 10V    | 0.00 to 10.00     |               | 23                |    |

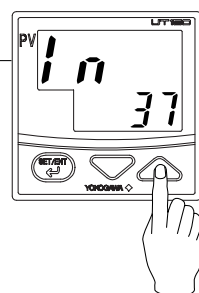

For example, to select thermocouple type E (°F), set the range code to 37.



## **WARNING**

---

To prevent electrical shock, the controller should be mounted on the panel so that you do not accidentally touch the terminals when power is being applied.

---



## **NOTE**

---

The temperature controller is shipped with the parameters set at the factory-set defaults. Check the default values against the “Parameter List” in the following page (P.14, 15), and change the parameter settings that need to be changed.

---

The following section explains how to set and register parameter values.

The procedure for changing SP (target setpoint) and A1 (alarm 1 setpoint) can be found on “Changing Target Setpoint (SP)” and “Changing Alarm 1 Setpoint (A1),” respectively. You can set the other parameters in the same way.

There are no setup displays for parameters specific to functions, such as the optional alarm output functions or heating/cooling control, if they were not selected at ordering.

The setting of some parameters (such as the control mode parameter CTL) determines whether the other parameters are displayed or not.

**The flowchart (P.13) will help you understand how this works.**

## ■ Changing Target Setpoint (SP)

The following instructions assume that the controller is already receiving power.

### Step 1:

Confirm that the controller shows the operation display ① during normal operation (PV and SP are displayed on the indicators).

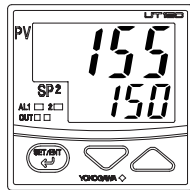

### Step 2:

Press the  $\triangle$  or  $\nabla$  key to change the displayed SP value to the required value. In this example, SP is changed to 200°C.

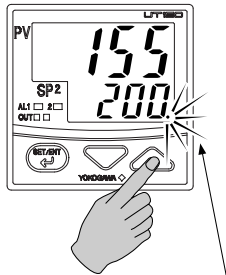

The period flashes while the value is being changed.

### Step 3:

Press the  $\text{ENTER}$  key once to register the setting.

SP is now changed.

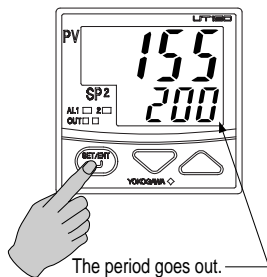

The period goes out.

## ■ Changing Alarm 1 Setpoint (A1)

(This setpoint appears only if the /AL or /HBA option is specified.)

### Step 1:

Confirm that the controller shows the operation display ① during normal operation (PV and SP are displayed on the indicators).

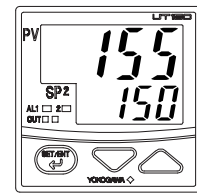

### Step 2:

To enter the operation parameter setting display, press the  $\text{ENTER}$  key for at least 3 seconds.

If your controller has the /AL or /HBA option, the display for the Alarm 1 setpoint (A1) appears. {If not, control mode (CTL) appears.}

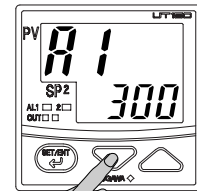

Press for at least 3 seconds.

### Step 3:

Press the  $\triangle$  or  $\nabla$  key to change the current A1 value to a desired value. In this example, A1 is changed to 200°C.

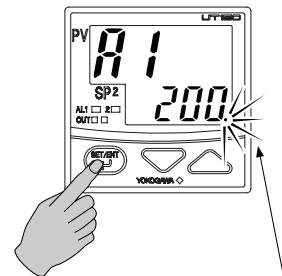

The period flashes while the value is being changed.

### Step 4:

Press the  $\text{ENTER}$  key once to register the setting.

A1 is now changed.

Another press of the

$\text{ENTER}$  key calls up the Alarm 2 setpoint display.

To return to the operation

display ①, press the  $\text{ENTER}$  key for at least 3 seconds.

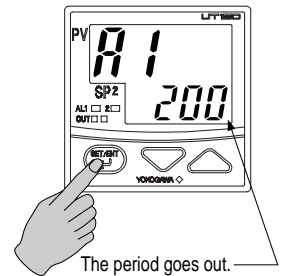

The period goes out.

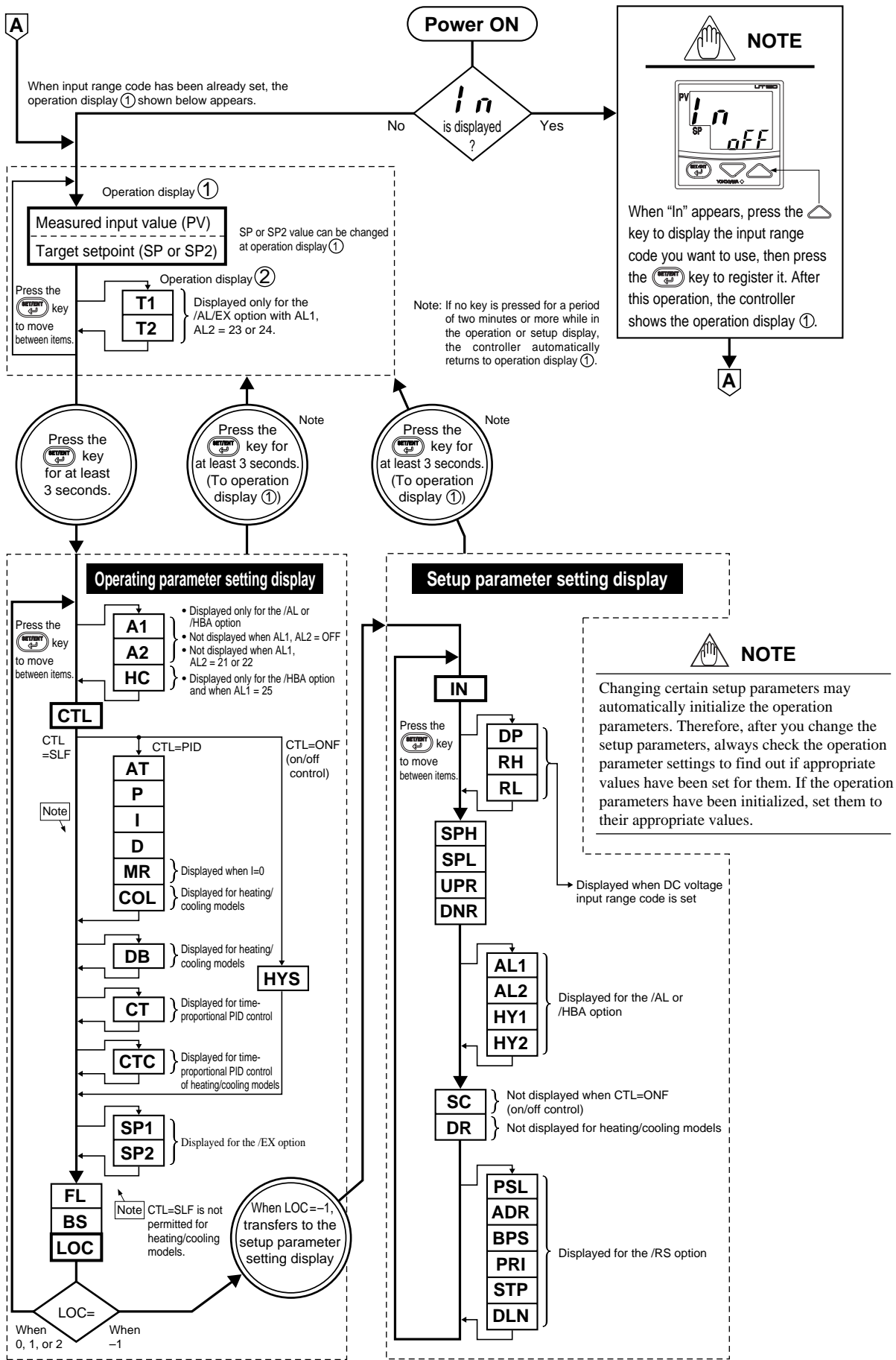

## ■ Parameter Lists

### ■ Parameter Lists

#### (1) Target Setpoint (SP) and Timer Setting 1 and 2

| Code               | Name            | Setting range and unit  | Default | User setting |
|--------------------|-----------------|---|---------|--------------|
| (SP value display) | Target setpoint | Minimum value (SPL) to maximum value (SPH) of target setpoint range<br>Unit: °C                 | SPL     |              |
| T1                 | Timer setting 1 | 0.0 to 99.59<br>Unit: minutes and seconds<br>For example, 15.25 sets 15 minutes and 25 seconds. | 0.00    |              |
| T2                 | Timer setting 2 |   | 0.00    |              |

#### (2) Operating Parameters

| Code | Name                                      | Setting range and unit   | Default  | User setting |
|------|---|--|--|--------------|
| A1   | Alarm 1 setpoint                          | <ul style="list-style-type: none"> <li>■ PV alarm Unit: °C/°F<br/>Setting range: minimum value to maximum value of measurement range</li> <li>■ Deviation alarm Unit: °C/°F<br/>Setting range: -100 to 100% of the measurement range span</li> </ul>       | Max. value of measurement range (PV alarm)         |              |
| A2   | Alarm 2 setpoint                          | <ul style="list-style-type: none"> <li>■ Heater burnout alarm Unit: A (ampere)<br/>Setting range: OFF, 1 to 80<br/>(can be set for the alarm 1 setpoint only)</li> </ul>   | Min. value of measurement range (PV alarm)         |              |
| HC   | Heater current measured value             | “HC” is not a parameter to be set. The current value (0 to 80) of heater burnout detector is displayed. Unit: A (ampere)<br>Settings: When the display value is ----, the heater current is not being measured.  |  |              |
| CTL  | Control mode                              | ONF: On/off control<br>PID: PID control<br>SLF: Dynamic auto tune control (cannot be set for heating/cooling control)  | SLF for general; PID (for heating/cooling control) |              |
| AT   | Auto-tuning                               | OFF: Stop auto-tuning<br>ON: Start auto-tuning   | OFF  |              |
| P    | Proportional band                         | 1°C/°F to the temperature that corresponds to 100% of the measurement range span   | 5% of measurement range span                       |              |
| I    | Integral time                             | 1 to 3600 seconds;<br>0: no integral action  | 240 seconds  |              |
| D    | Derivative time                           | 1 to 3600 seconds;<br>0: no derivative action  | 60 seconds   |              |
| MR   | Manual reset                              | -100 to 100%   | 50.0%; 0.0% for heating/cooling models             |              |
| COL  | Cooling-side gain                         | 0.01 to 9.99 times   | 1.00 times   |              |
| DB   | Deadband                                  | <ul style="list-style-type: none"> <li>■ PID control Unit: °C/°F<br/>Setting range: -(proportional band setting) to +(proportional band setting)</li> <li>■ On/off control Unit: °C/°F<br/>Setting range: -50 to +50% of measurement range span</li> </ul> | 3% of measurement range span                       |              |
| HYS  | Hysteresis for on/off control             | 0°C/°F to the temperature that corresponds to 100% of the measurement range span   | 0.5% of measurement range span                     |              |
| CT   | Cycle time of control output              | 1 to 240 seconds   | 30 seconds   |              |
| CTC  | Cycle time of cooling-side control output | 1 to 240 seconds   | 30 seconds   |              |
| SP1  | Target setpoint 1                         | Minimum value (SPL) to maximum value (SPH) of target setpoint range  | SPL  |              |
| SP2  | Target setpoint 2                         | Unit: °C/°F<br>There are also optional engineering units for voltage input.  | SPL  |              |
| FL   | Input filter                              | OFF, 1 to 120 seconds  | 2 seconds  |              |
| BS   | PV bias                                   | -100 to 100% of measurement range span   | 0% of instrument range span                        |              |
| LOC  | Key lock                                  | 0: No key lock<br>1: Prevents operations from being changed except for the changing of SP in the operation display<br>2: Prevents all parameter changing operations<br>-1: Set to enter the setup parameter setting display                                | 0  |              |

### (3) Setup Parameters

| Code           | Name                                   | Setting range and unit  | Default   | User setting |
|----------------|--|---|---|--------------|
| IN <i>ln</i>   | Input type                             | 1 to 23 (See input range code list.)<br>OFF: No input<br>(If no input type is specified at the time of ordering, you must set the input type.)  | OFF, or the input range code specified with order |              |
| DP <i>dp</i>   | Decimal point position of input        | 0: No decimal place (nnnn)<br>1: One decimal place (nnn.n)<br>2: Two decimal places (nn.nn)<br>3: Three decimal places (n.nnn)  | 1   |              |
| RH <i>rH</i>   | Maximum value of measurement range     | (RL + 1) to 9999  | 100.0   |              |
| RL <i>rL</i>   | Minimum value of measurement range     | -1999 to (RH - 1)   | 0.0   |              |
| SPH <i>SPH</i> | Maximum value of target setpoint range | (SPL value +1°C) to the maximum value of the measurement range; Unit: °C/°F   | Maximum value of measurement range                |              |
| SPL <i>SPL</i> | Minimum value of target setpoint range | Minimum value of measurement range to (SPH -1°C)<br>Unit: °C/°F   | Minimum value of measurement range                |              |
| UPR <i>UPr</i> | Slope for rising setpoint              | OFF (no slope)<br>or a value from the minimum to the maximum value of the measuring range<br>Unit: °C/min or °F/min   | OFF (no slope)                                    |              |
| DNR <i>dnr</i> | Slope for falling setpoint             |   | OFF (no slope)                                    |              |
| AL1 <i>AL1</i> | Alarm 1 type                           | OFF or a value from 1 to 22 (see the table of alarm function list), and either 23 or 24 (if the timer function [/EX option] is included), and 25 (if the heater disconnection function [/HBA option] is included) | 1<br>(PV high limit alarm)                        |              |
| AL2 <i>AL2</i> | Alarm 2 type                           | OFF or a value from 1 to 22 (see the table of alarm function list), and either 23 or 24 (if the timer function [/EX option] is included)  | 2<br>(PV low limit alarm)                         |              |
| HY1 <i>HY1</i> | Alarm 1 hysteresis                     | 0 to 100% of measurement range span<br>Unit: °C/°F  | 0.5% of measurement range span                    |              |
| HY2 <i>HY2</i> | Alarm 2 hysteresis                     |   |   |              |
| SC <i>SC</i>   | SUPER function                         | ON: Uses the SUPER function<br>OFF: Does not use SUPER function<br>Note: Not displayed when on/off control  | OFF   |              |
| DR <i>dr</i>   | Direct/reverse action                  | 0: Reverse action<br>1: Direct action<br>Note: Not displayed on heating/cooling models  | 0   |              |
| PSL <i>PSL</i> | Protocol selection                     | 0: PC-link communication<br>1: PC-link communication with sum check<br>2: Ladder communication<br>3: Modbus in ASCII mode<br>4: Modbus in RTU mode  | 0   |              |
| ADR <i>Adr</i> | Controller address                     | 1 to 99<br>However, the number of controllers that can be connected per host device is 31 at the maximum.   | 1   |              |
| BPS <i>bPS</i> | Baud rate                              | 2.4: 2400 bps<br>4.8: 4800 bps<br>9.6: 9600 bps   | 9.6   |              |
| PRI <i>Pri</i> | Parity                                 | NON: Disabled<br>EVN: Even parity<br>ODD: Odd parity  | EVN   |              |
| STP <i>StP</i> | Stop bit                               | 1 or 2 bits   | 1 bit   |              |
| DLN <i>dLn</i> | Data length                            | 7 or 8 bits<br>• 8 bits when ladder, MODBUS (RTU)<br>• 7 bits when MODBUS (ASCII)   | 8 bits  |              |

## Alarm Function List

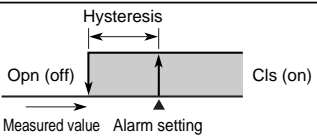
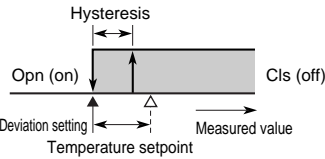
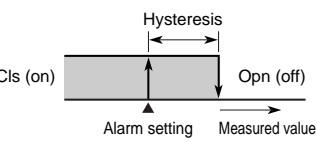
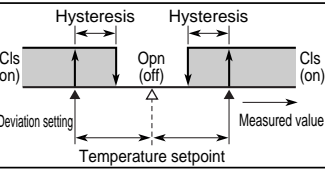
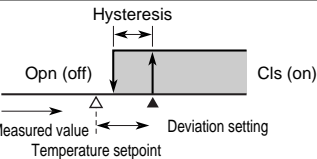
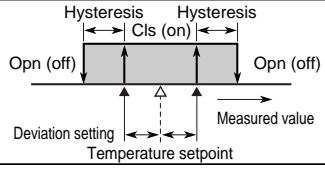
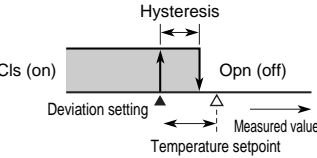
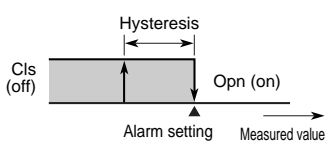
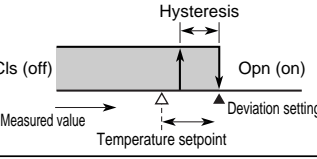
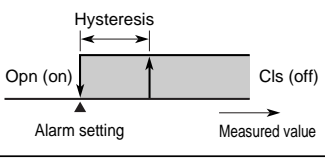
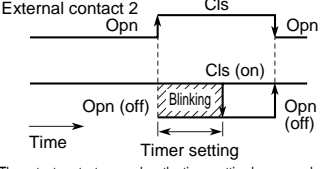
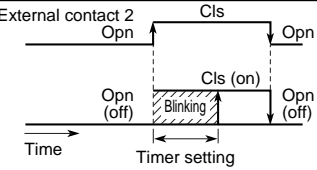
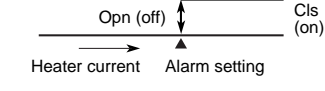
| Alarm type                          | Action<br>("Opn" and "Cls" indicate that the relay contact is opened and closed; "on" and "off" indicate that the lamp is on and off; and white triangles indicate temperature control setpoints.)  | Alarm type code             |                           | Alarm type                          | Action<br>("Opn" and "Cls" indicate that the relay contact is opened and closed; "on" and "off" indicate that the lamp is on and off; and white triangles indicate temperature control setpoints.) | Alarm type code             |                           |
|-------------------------------------|---|-----------------------------|---------------------------|-------------------------------------|--|-----------------------------|---------------------------|
|                                     |   | Closed contact during alarm | Open contact during alarm |                                     |  | Closed contact during alarm | Open contact during alarm |
| No alarm                            |   | OFF                         |                           |                                     |  |                             |                           |
| PV high limit                       |    | 1<br>11<br>(See note.)      |                           | Deenergized on deviation low limit  |    |                             | 6<br>16<br>(See note.)    |
| PV low limit                        |    | 2<br>12<br>(See note.)      |                           | Deviation high and low limit        |    | 7<br>17<br>(See note.)      |                           |
| Deviation high limit                |    | 3<br>13<br>(See note.)      |                           | Deviation within-high-and-low-limit |    | 8<br>18<br>(See note.)      |                           |
| Deviation low limit                 |    | 4<br>14<br>(See note.)      |                           | Deenergized on PV high limit        |    | 9<br>19<br>(See note.)      |                           |
| Deenergized on deviation high limit |   | 5<br>15<br>(See note.)      |                           | Deenergized on PV low limit         |   | 10<br>20<br>(See note.)     |                           |
| Self-diagnostics alarm              | The contact is closed at input burnout.   | 21                          |                           | Break timer function                |    | 24                          |                           |
| Failure alarm                       | The output contact is opened in the following events:<br><ul style="list-style-type: none"> <li>• Program error</li> <li>• ROM error</li> <li>• RAM error</li> <li>• power failure</li> <li>• A/D converter error</li> <li>• RJC error</li> <li>• EEPROM error</li> </ul> | 22                          |                           |                                     |  |                             |                           |
| Timer function                      | <br>The output contact closes when the timer setting has passed since external contact was closed. Then, the output contact opens immediately when external contact is opened.         | 23                          |                           | Heater disconnection alarm          |    | 25                          |                           |

Note: The alarms numbered 1 to 10 have no waiting action, while alarms 11 to 20 have a waiting action.

The waiting action turns off the PV and deviation alarms that occur from the start of the control operation until a stable state is reached.

Waiting action

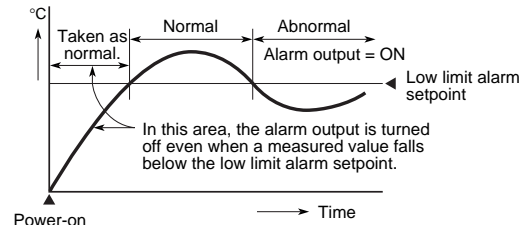

## ■ Description of Parameters

This section describes the parameter functions specific to the UT150/UT152/UT155 temperature controllers. (The functions described in other sections of this manual and the general functions are not discussed.)

| Parameter      | Function  | Parameter       | Function  |
|----------------|---|-----------------|---|
| <b>CTL</b>     | <p>Control mode</p> <p>Select one from the following:</p> <ol style="list-style-type: none"> <li>Dynamic auto tune control (SLF) (See note)</li> <li>PID control (PID)</li> <li>On/off control</li> </ol> <p>Note: Dynamic auto tune control is not available for heating/cooling control.</p> <p>Read the section in Page 18 to find out more about dynamic auto tune control.</p>   | <b>PV bias</b>  | <p>This function adds a bias value to the measured input value, and the result is used for display and control computation.</p> $\boxed{\text{PV value inside the controller}} = \boxed{\text{measured input value}} + \boxed{\text{PV bias}}$  |
| <b>BS</b>      | <p>Manual reset</p> <p>You can set this parameter only for control without an integral action (when registered as CTL=PID and I=0). The controller outputs the manual reset (MR) value when PV=SP. For example, if you set MR=50%, the controller outputs (OUT) 50% when PV=SP.</p>   | <b>BS</b>       | <p>This function is useful for carrying out fine adjustment when the PV value is within the required accuracy but it differs from the value obtained by other equipment.</p>  |
| <b>MR</b>      | <p>Manual reset</p> <p>You can set this parameter only for control without an integral action (when registered as CTL=PID and I=0). The controller outputs the manual reset (MR) value when PV=SP. For example, if you set MR=50%, the controller outputs (OUT) 50% when PV=SP.</p>   | <b>DP</b>       | <p>Decimal point of input</p> <p>For DC voltage input, the input signal can be scaled for the particular engineering unit. For example, if you set the input type (IN) at range code 22, the initial range is 0.0 to 100.0.</p> <ol style="list-style-type: none"> <li>Using PD, set the decimal point position fit for the engineering unit you want to use. (In the example below, the 2 digits to the right of the decimal point)</li> <li>Next, register the scale values of the measurement range using RH and RL. (In the example below, RH=10.00 and RL=0.00)</li> </ol> |
| <b>COL</b>     | <p>Cooling-side gain</p> <p>For heating/cooling control, you can set the ratio between the cooling-side output and heating-side output.</p> <p>For example, if you set COL=2.0 and the heating-side output is 10% at a certain deviation (SP-PV), then the cooling-side output will be 20% when the cooling-side also reaches that deviation.</p>   | <b>RH, RL</b>   |   |
| <b>COL</b>     | <p>Cooling-side gain</p> <p>For heating/cooling control, you can set the ratio between the cooling-side output and heating-side output.</p> <p>For example, if you set COL=2.0 and the heating-side output is 10% at a certain deviation (SP-PV), then the cooling-side output will be 20% when the cooling-side also reaches that deviation.</p>   | <b>SPH, SPL</b> | <p>Maximum/minimum value of target setpoint range</p> <p>Using the SPH and SPL parameters, you can limit the setting range of the target setpoint (SP) within the measured input range.</p> <p>This function prevents SP from being mistakenly set at too large or too small a value (beyond the setting range).</p>  |
| <b>DB</b>      | <p>Deadband</p> <p>You can only set a deadband for heating/cooling control. In a positive deadband, there are neither heating-side nor cooling-side outputs. In a negative deadband, there are both heating-side and cooling-side outputs, which overlap each other.</p> <ol style="list-style-type: none"> <li>When the deadband of a heating/cooling model is positive (Proportional band [P] control)</li> <li>When both the heating and cooling sides are under on-off control</li> </ol> | <b>UPR, DNR</b> | <p>Setpoint ramp up/ramp-down rate</p> <p>To prevent a sudden change in SP, or to change SP at a constant rate, ramp-up and ramp-down rates can be set separately. This function operates at the following events.</p> <ol style="list-style-type: none"> <li>SP change</li> <li>SP/SP2 switching</li> <li>Power-on</li> </ol> <p>At power-on, SP starts from the current PV value.</p>   |
| <b>DB</b>      | <p>Deadband</p> <p>You can only set a deadband for heating/cooling control. In a positive deadband, there are neither heating-side nor cooling-side outputs. In a negative deadband, there are both heating-side and cooling-side outputs, which overlap each other.</p> <ol style="list-style-type: none"> <li>When the deadband of a heating/cooling model is positive (Proportional band [P] control)</li> <li>When both the heating and cooling sides are under on-off control</li> </ol> | <b>HYS</b>      | <p>Hysteresis for on/off control</p> <p>For on/off control (CTL=ONF), you can set a hysteresis band around the on/off point (SP) to prevent chattering.</p>   |
| <b>HYS</b>     | <p>Hysteresis for on/off control</p> <p>For on/off control (CTL=ONF), you can set a hysteresis band around the on/off point (SP) to prevent chattering.</p>   | <b>CT, CTC</b>  | <p>Cycle time of control output</p> <p>The cycle time is the period of on/off repetitions of a relay or voltage pulse output in time proportional PID control. The ratio of the ON time to the cycle time is proportional to the control output value.</p>  |
| <b>CT, CTC</b> | <p>Cycle time of control output</p> <p>The cycle time is the period of on/off repetitions of a relay or voltage pulse output in time proportional PID control. The ratio of the ON time to the cycle time is proportional to the control output value.</p>  | <b>FL</b>       | <p>Super function selection</p> <p>The SUPER function is effective in the following cases:</p> <ol style="list-style-type: none"> <li>An overshoot must be suppressed.</li> <li>The rise-up time needs to be shortened.</li> <li>The load often varies.</li> <li>SP is changed frequently.</li> </ol> <p>Note 1: The SUPER function will not work when on/off control is selected, or I or D constants is set at 0 in PID control.</p> <p>Note 2: For some types of systems, the SUPER function may not be so useful. If this is the case, turn off the function.</p>           |
| <b>FL</b>      | <p>Input filter</p> <p>This function should be used when the PV display value may fluctuate greatly, for example, when the measured input signal contains noise. The filter is of the first-order lag type, and FB sets the time constant. If a larger time constant is set, the filter can remove more noise.</p>  | <b>SC</b>       | <p>Super function selection</p> <p>The SUPER function is effective in the following cases:</p> <ol style="list-style-type: none"> <li>An overshoot must be suppressed.</li> <li>The rise-up time needs to be shortened.</li> <li>The load often varies.</li> <li>SP is changed frequently.</li> </ol> <p>Note 1: The SUPER function will not work when on/off control is selected, or I or D constants is set at 0 in PID control.</p> <p>Note 2: For some types of systems, the SUPER function may not be so useful. If this is the case, turn off the function.</p>           |

## ■ What is Dynamic Auto Tune Control?

Dynamic auto tune control is one of the features offered by the temperature controller.

When the controller is turned on or the process variable (PV) starts “hunting”, this mode of control monitors the behavior of the PV and/or OUT (control output value) to automatically determine the optimum PID constants. This means that the PID constants may be changed automatically. If this is not desirable for your system, operate the controller in the normal “PID control”.

If you want to automatically determine the PID constants at the initial startup of the controller, first define the target setpoint variable (SP) and then turn the controller off once and then back on again. Do not use dynamic auto tune control for a system where there is interference or continual disturbances.



### **IMPORTANT**

---

To use dynamic auto tune control,

- (1) be sure to turn on the final control element, such as a heater, before starting the control, and
- (2) make sure the controlled loop is a closed loop.

If you do not follow these precautions, improper PID constants may be written into the controller. If this occurs, carry out the following:

- Set the parameter CTL at PID.
- Set the PID constants at the factory-set defaults ( $P = (\text{upper range-limit} - \text{lower range-limit}) \times 5\%$ ;  $I = 240 \text{ sec.}$ ; and  $D = 60 \text{ sec.}$ )
- Set the parameter CTL at SLF.

If the control still doesn't work properly, stop using the dynamic auto tune control function. Change the parameter CTL setting to PID and execute auto-tuning to obtain the PID constants.

---

# 8. TROUBLESHOOTING

In the event of an abnormality, perform the following checks as outlined by the flowchart.

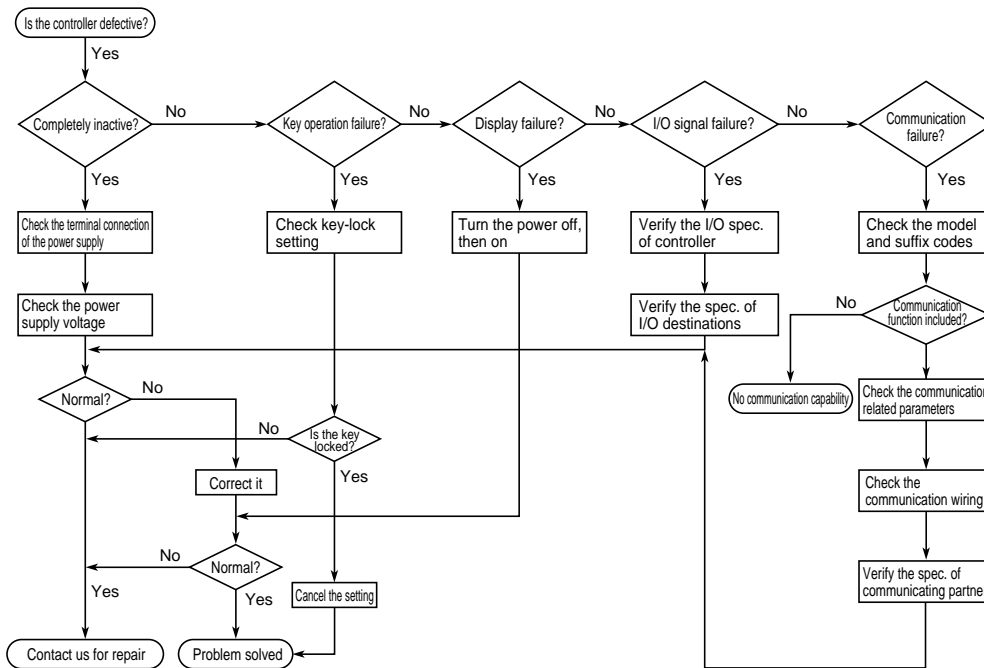

## ■ Error Display during Operation

(1) If the controller displays one of the following, carry out the appropriate remedy for the particular error.

| Display          | Error content   | Remedy  |
|------------------|---|---|
| <i>P.Er</i> P.Er | The parameter is abnormal                               | Check the settings of all the parameters and set them at their proper values. |
| <i>b.o</i> B.o   | Input burnout   | Check the sensor wiring and correct it.                                       |
| <i>ooo</i> OOO   | PV over-scale<br>(PV exceeds its effective range.)      | Check the input type and range settings and correct them.                     |
| <i>uuu</i> UUU   | PV under-scale<br>(PV falls below its effective range.) |   |
| Flashing period  | Communication failure<br>(for /RS option only)          | Press any key to stop the flashing.   |

(2) The controller needs to be repaired if any of the indications in the table below appear.

In these cases, do not try to repair the controller yourself. Order a new controller or contact us for repair.

| Display                        | Error content        | Display                           | Error content   |
|--------------------------------|----------------------|-----------------------------------|---|
| Unknown (at power-on)          | CPU failure          | Flashing "Err" (at power-on)      | RAM or ROM failure                                    |
| All extinguished (at power-on) | Power source failure | Flashing "Err" (during operation) | A/D converter failure, RJC failure, or EEPROM failure |
| "Err" (at power-on)            | Calibration abnormal |                                   |   |

## ■ When Power Failure Occurred during Operation

- Momentary power failures of less than 20msec. have no effect on the controller operation (i.e., normal operation continues).
- For power failures longer than 20msec, however the status will be as follows.  
(The controller action at power recovery is the same as at power-on.)
  - Alarm action: Continues (but alarms with a waiting action enter the waiting state once)
  - Parameter settings: Maintained
  - Auto-tuning: Canceled

**YOKOGAWA**   
Yokogawa M&C Corporation

World Wide Web. site at  
[http://www.yokogawa.co.jp/MCC/Welcome\\_e.htm](http://www.yokogawa.co.jp/MCC/Welcome_e.htm)

**NOTICE**

- Before using the product, read the instruction manual carefully to ensure proper operation.

**YOKOGAWA M&C CORPORATION  
International Operations**

Kojimachi-Tokyu Bldg, 3F  
6-6 Koji-machi, Chiyoda-ku, Tokyo, 102-0083 Japan  
Phone : 81-3-3239-0576 Facsimile : 81-3-3239-0585

**YOKOGAWA CORPORATION OF AMERICA**  
2 Dart Road, Newnan, Ga. 30265-1094, U.S.A.  
Phone : 1-770-253-7000 Facsimile : 1-770-251-2088

**YOKOGAWA EUROPE B. V.**  
Radiumweg 30, 3812 RA, Amersfoort, THE NETHERLANDS  
Phone : 31-33-464-1611 Facsimile : 31-33-464-1856  
Telex : 79118 YEF NL

**YOKOGAWA AMERICA DO SUL S. A.**  
Avenida Jura, 149-AlphaVillage,  
06455-010-Barueri, Sao Paulo, BRAZIL  
Phone : 55-11-7295-1433 Facsimile : 55-11-7295-1329

**YOKOGAWA ENGINEERING ASIA PTE. LTD.**  
11 Tampines Street 92, Singapore 528872, SINGAPORE  
Phone : 65-783-9537 Facsimile : 65-786-6550  
Telex : RS-26137 YASSIN

**HANKUK YOKOGAWA ELECTRIC CO., LTD.**  
K. P. O. Box : 403, Chongohon-2dong, Pupyong-ku,  
Inchon, KOREA  
Phone : 82-32-510-3304 Facsimile : 82-32-529-6301/6302

**YOKOGAWA TAIWAN CORPORATION**  
Fu Chi Bldg. 6th Floor, 99Jon-ai Road,  
2nd Section, Taipei, TAIWAN  
Phone : 866-2-321-1113 Facsimile : 866-2-322-5593

**YOKOGAWA AUSTRALIA PTY. LTD.**  
Private mail bag 24, Centre Court D3, 25-27  
Paul Street North, North Ryde, N. S. W.  
2113, AUSTRALIA  
Phone : 61-2-9805-0699 Facsimile : 61-2-9888-1844

**YOKOGAWA BLUE STAR LTD.**  
40/4 Lavelle Road, Bangalore 560 001, INDIA  
Phone : 91-80-227-1513 Facsimile : 91-80-227-4270

**LTD. YOKOGAWA ELECTRIC**  
Hotel International No. 2, Room 1047, Krasnopresnenskaja Nab.  
12, Moscow 123610, RUSSIAN FEDERATION  
Phone : 7-095-967-0350 Facsimile : 7-502-253-3509

Represented by :

Subject to change without notice.

All Rights Reserved, Copyright © 1998, Yokogawa M&C Corporation.

Note: This instruction manual (IM 5C1E11-41E) is a re-edited, A4-size version of the IM 5C1E11-01E instruction manual that is supplied along with the product shipped. Therefore, both manuals have the same contents, except for some minor differences in the cross-referenced page numbers.