

UT1000 Temperature Controllers

SERIES

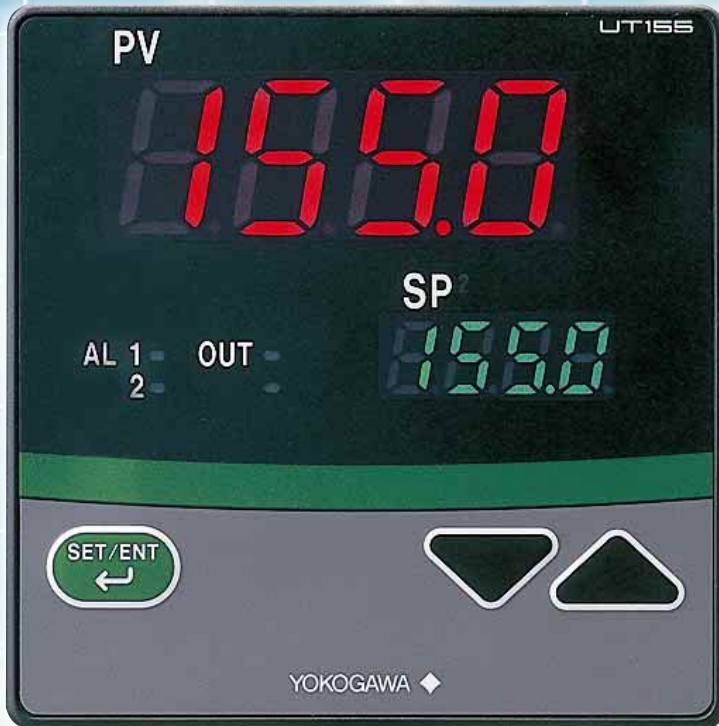

Yokogawa M&C Corporation

UT100 - The Perfect Solution

The UT100 series meets almost every conceivable need.



Q1 Is it easy for first-time users to operate?

A1: Yes! Install it, connect the wiring, and your UT controller will start operating. The Dynamic Auto Tune control eliminates troublesome tuning work. You only have to set the temperature setpoint.

Q2 Is the display easy to read with such a compact body?

A2: Yes! The display is large. Characters on the LED display of the UT130, for example, are 17.5mm high.

Q3 Can a small 1/16 DIN controller perform heating/cooling control?

A3: Yes! For all models, you can specify the heating/cooling control function when ordering.

Q4 Can it communicate with a personal computer and a programmable controller?

A4: Yes! A two-wire RS-485 port can be specified (option code /RS) for all models. MODBUS, Personal Computer link or Radder communication can be selected by software.

Q5 How do I record the temperature?

A5: The UT150, UT152, and UT155 can transmit the measured value (PV). By specifying the option code /RET, your UT controller will output the measured value(PV) as a 4to20 mA signal, which can then be connected to a recorder.

Dynamic Auto Tune

The best PID parameter settings for the new setpoint!

The Dynamic Auto Tune function of the UT100 series assures stable control. Whenever you change the setpoint (SP), the function automatically tunes the PID parameters and updates them to the suitable settings. And also **SUPER** fuzzy function prevents over shooting.

The Dynamic Auto Tune function may not operate if the input-output response is too quick or too slow (delay time is too large). In this case, use the Auto-tuning function or set the PID parameters manually.

Extensive Alarm Functions

Various alarm types are offered by the /AL, /HBA, and /EX options.

Q6 I want the controller to output a signal notifying that a preset time is an external timer required?

A6: A timer function can be provided in the UT150, UT152, and UT155 (option code /E energizes (or de-energizes depending on the specification) an output relay upon time-

Q7 Can UT100 series be used in dusty or wet environmen

A7: Yes! The front panel has a rugged splash-proof and dust-proof design (IP65*). When mounted on a panel, you can wash it by hose from the front. (*IP65:UT130/UT150, IP55:152/UT155)



Q8 Can it be used anywhere in the world?

A8: Yes! The UT100 series controllers all comply with international safety standards including UL, CSA, and CE mark.

Q9 Is product quality control trustworthy?

A9: We are proud of our quality control. All products are manufactured at factories that have obtained ISO9001 approval. We inspect each product and ship only those that pass our strict inspections. If desired, we can also provide the calibration certificate that states the traceability system of the reference equipment used for testing and inspections.



Simple Design, All The Necessary Fun

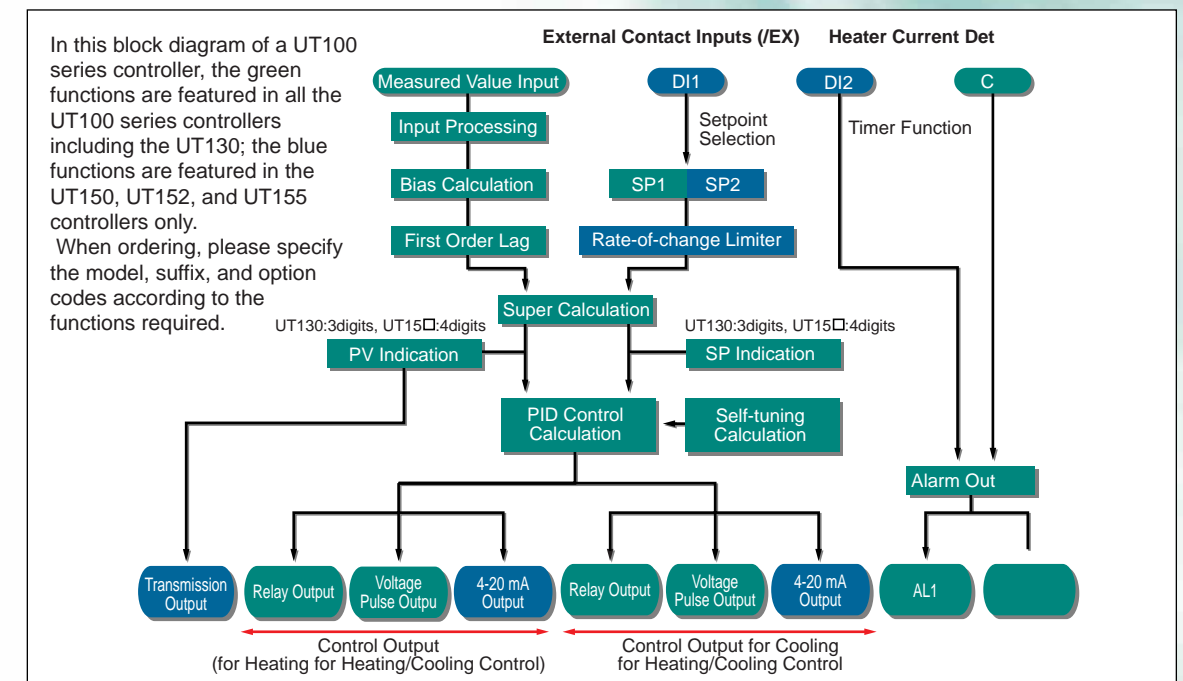

Reduce Instrumentation Costs!

List of UT100 Series Temperature Controllers



Common Specifications

- Selectable control type—standard type or heating/cooling type
- Optional communication function—MODBUS, personal computer link or ladder communication.
- Safety and EMC standards—CSA, UL, and CE mark
- Dust-proof and splash-proof (front panel)
- Universal power supply, low power consumption of max. 8 VA

1/16DIN Temperature Controller with Large 3-digit Display (One display for PV or SP)

UT130

Dynamic Auto Tune

48 (H) x 48 (W) x 100 (D) mm, 200 g



1/16DIN Temperature Controller with 4-digit Display (for PV and SP Indication)

UT150

Dynamic Auto Tune

48 (H) x 48 (W) x 100 (D) mm, 200g



1/8DIN Temperature Controller with Large 4-digit Display (for PV and SP Indication)

UT152

Dynamic Auto Tune

48 (H) x 96 (W) x 100 (D) mm, 300g



1/4DIN Temperature Controller with Large 4-digit Display (for PV and SP Indication)

UT155

Dynamic Auto Tune

96 (H) x 96 (W) x 100 (D) mm, 400g



Display digits (main display)	3 digits (PV or SP)	4 digits (x2 sets for PV and SP)	4 digits (x2 sets for PV and SP)
Input accuracy; sampling period for measured value input	±2°C, 500 ms	±2°C(Thermocouple/RTD), ±0.3%(DC Voltage), 500 ms	±2°C(Thermocouple/RTD), ±0.3%(DC Voltage), 500 ms
Temperature setpoints (SP)	1 setpoint only	2 setpoints	2 setpoints
Input	Input type selection method	Universal input (See Table 1.)	Universal input (See Table 2.)
	Thermocouple	K, J, T, E, L, U	K, J, T, E, R, S, B, N, L, U, platinum 2
	RTD	Pt100, JPt100	Pt100, JPt100
	DC voltage	Not available	0 to 100 mV, 0 to 5 V, 1 to 5 V, 0 to 10 V
Output	Output type selection method	Specify when ordering.	Specify when ordering.
	Time-proportional PID	Relay contact or voltage pulse	Relay contact or voltage pulse
	Continuous PID	Not available	4 to 20 mA DC
	On/off	Relay contact	Relay contact
Alarm	Number of output points; alarm types (option code /AL or /HBA)	2 points; selectable from 22 alarm types	2 points; selectable from 22 alarm types
	Timer function (option code /EX/AL or /EX/HBA)	Not available	2 types
	Heater disconnection alarm (option code /HBA)	1 type	1 type
Transmission output (option code /RET)	Not available	4 to 20 mA DC output of process value (PV)	4 to 20 mA DC output of process value (PV)
External contact switching (option code /EX)	Not available	Switching over the setpoint between SP1 and SP2	Switching over the setpoint between SP1 and SP2
Communication function (option code /RS)	MODBUS, Personal computer link, Ladder Communication	MODBUS, Personal computer link, Ladder Communication	MODBUS, Personal computer link, Ladder Communication

Applications

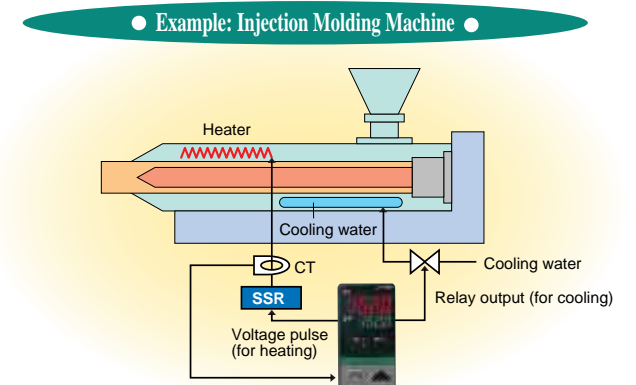
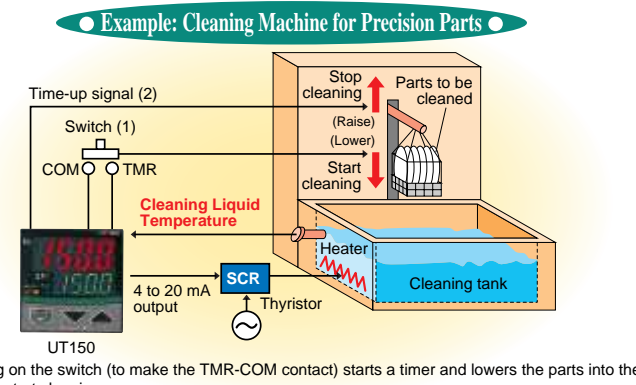
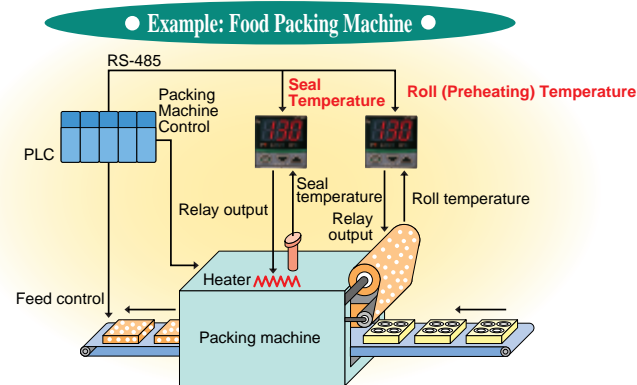

Model and suffix codes

Note : When specifying the /RS option, be sure to order the required number of copies of the Communication Function Instruction manual (IM5CIE11-10E) separately.

Model	Suffix Code	Description	Model	Suffix Code	Description	Model	Suffix Code	Description
UT130	-□ □	Temperature controller	UT150	-□ □	Temperature controller	UT152	-□ □	Temperature controller
Output signal (for heating) Note 1	-R	Relay contact output (for time-proportional PID or on/off control)	Output signal (for heating) Note 1	-R	Relay contact output (for time-proportional PID or on/off control)	Output signal (for heating) Note 1	-R	Relay contact output (for time-proportional PID or on/off control)
	-V	Voltage pulse output (for time-proportional PID)		-V	Voltage pulse output (for time-proportional PID)		-V	Voltage pulse output (for time-proportional PID)
Output signal for cooling	N	No cooling output (Standard type)	Output signal for cooling	N	No cooling output (Standard type)	Output signal for cooling	N	No cooling output (standard type)
	R	Relay contact output (for time-proportional PID) Note 2		R	Relay contact output (for time-proportional PID control) Note 2		R	Relay contact output (for time-proportional PID control) Note 2
	V	Voltage pulse output (for time-proportional PID) Note 2		V	Voltage pulse output (for time-proportional PID) Note 2		V	Voltage pulse output (for time-proportional PID) Note 2
Option	/AL	Alarm outputs (2 points) Note 3	Option	/AL	Alarm outputs (2 points) Note 3	Option	/AL	Alarm outputs (2 points) Note 3
	/HBA	Heater burn-out alarm and 2 other alarm outputs Note 4 (includes the functions of /AL) Note 3		/HBA	Heater disconnection alarm and 2 other alarm outputs (includes the functions of /AL) Note 3, 4, 7		/HBA	Heater disconnection alarm and 2 other alarm outputs Note 1 (includes the functions of /AL) Note 3
	/RS	Communication function Note 4		/EX	Switchover between SP1 and SP2, and starting of timer by external contacts Note 5, 7		/EX	Switchover between SP1 and SP2, and starting of timer by external contacts
				/RET	4 to 20 mA output of measured value (PV) Note 4, 6		/RET	4 to 20 mA output of measured value (PV) Note 4
				/RS	Communication function Note 5, 7		/RS	Communication function

Note 1: Output signal of standard type or output signal for heating when selecting heating / cooling type. /HBA can not be specified when selecting "-A 4 to 20mA output".
 Note 2: Specify "R", "V" or "A" for the cooling output signal when the heating/cooling control is required.
 Note 3: /AL can not be specified when /HBA is specified as the /HBA option already includes the functions of the /AL option.
 Note 4: /HBA and /RET cannot be specified as same time when selecting standard type.
 Note 5: /EX and /RS cannot be specified as the same time when selecting standard type.
 Note 6: /RET cannot be specified when selecting heating/cooling type.
 Note 7: /HBA, /EX and /RS cannot be specified as the same time when selecting heating / cooling type.

Note 1: Output signal of standard type or output signal for heating when selecting heating / cooling type. /HBA can not be specified when selecting "-A 4 to 20mA output".
 Note 2: Specify "R", "V" or "A" for the cooling output signal when the heating/cooling control is required.
 Note 3: /AL cannot be specified when /HBA is specified as the /HBA option already includes the functions of the /AL option.
 Note 4: /RET cannot be specified when selecting heating/cooling type.

UT130 Terminal Arrangement

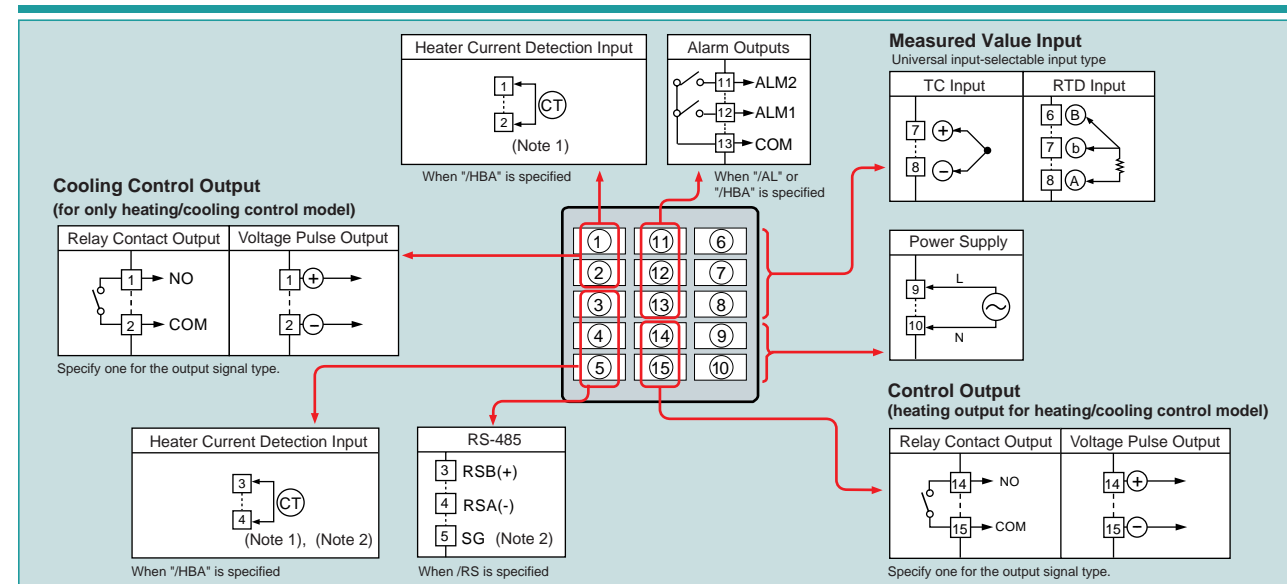

Note 1: The heater current detection input terminals (option code:/HBA) are defined as terminals 1 and 2 for a standard model and as terminals 3 and 4 for a heating/cooling model.
 Note 2: For a heating/cooling model, you are not allowed to specify both the /HBA and /RS options at the same time.

UT150 Terminal Arrangement

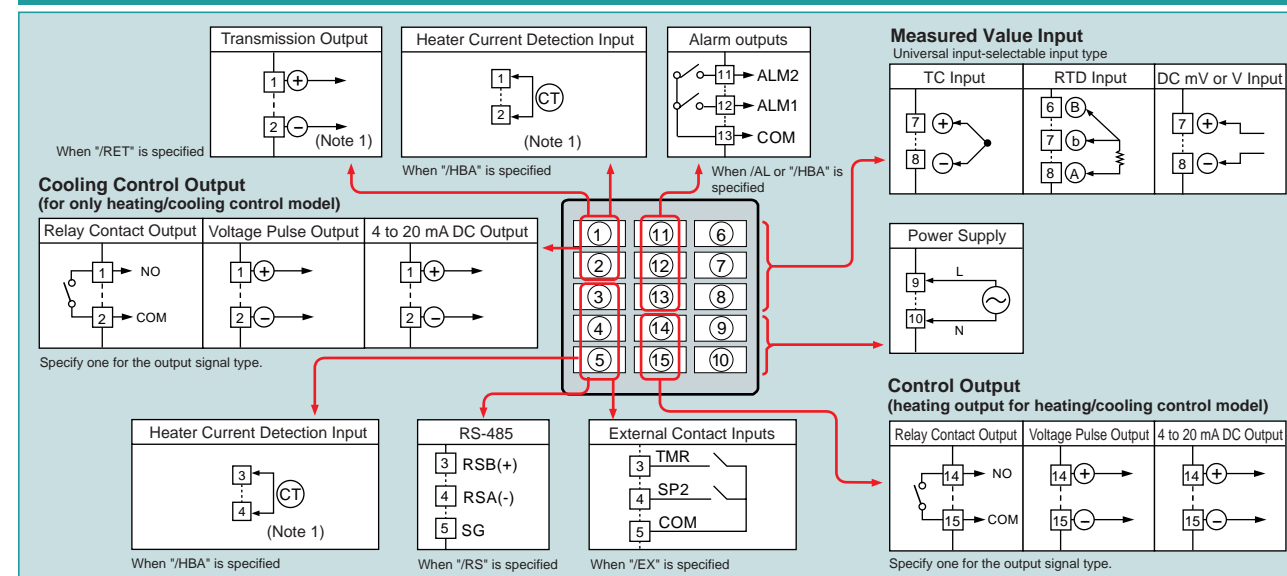

Note 1: The heater current detection input terminals (option code:/HBA) are defined as terminals 1 and 2 for a standard model, and as terminals 3 and 4 for a heating/cooling model. When the /RET option is specified, these terminals are defined as terminals 3 and 4.

UT152/UT155 Terminal Arrangement

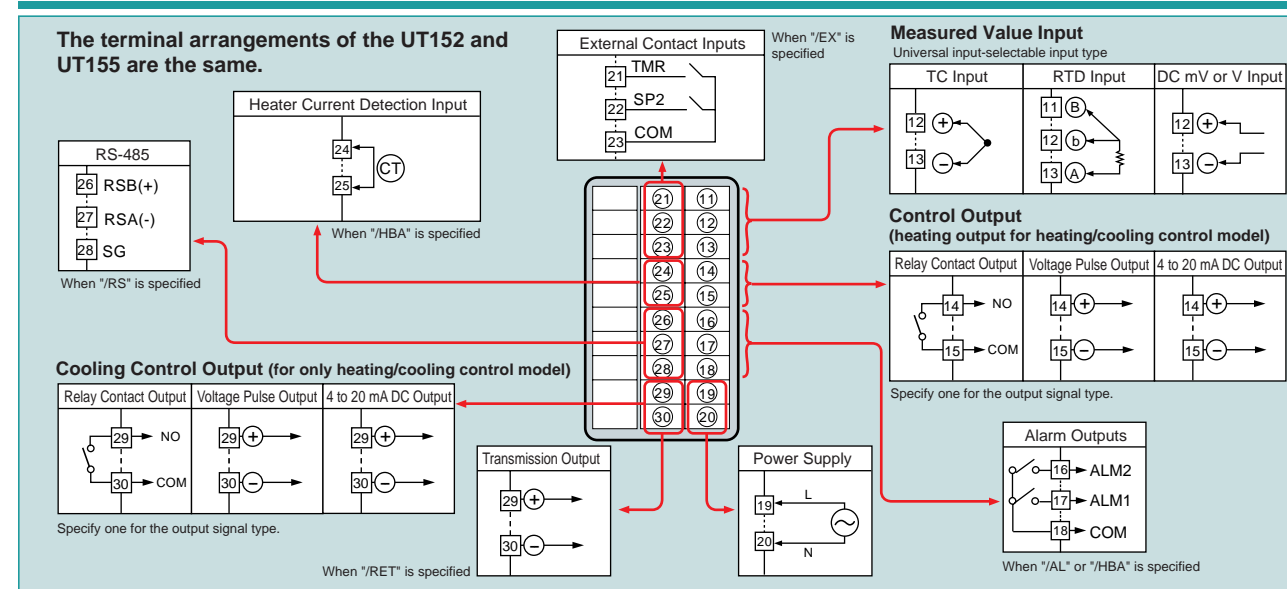

Hardware Specifications

Measured Value Input

Input: 1 point
Input type: Universal; can be selected by software (see Tables 1 and 2)
Input accuracy (at 23±2°C ambient temperature)
 • Thermocouple: ±2°C
 However,
 • +4°C for thermocouple input-200 to -100°C
 • +3°C for thermocouple input-100 to 0°C
 • +5°C for type R and S (±9°C for 0 to 500°C)
 • +9°C for type B (accuracy is not guaranteed for 0 to 400°C)
 • RTD: ±1°C ±1 digit
 • Voltage (mV, V) ±0.3%
Sampling period for measured value input: 500 ms
Burn-out detection: Functions for thermocouple or RTD input (burn-out upscale only; cannot be switched off)
Input resistance:
 • 1 MΩ or greater for thermocouple or DC mV input
 Approx. 1 MΩ for DC V input
Maximum allowable load resistance: 250 Ω for thermocouple or DC mV input 2 kΩ for DC V input
 • Effect of signal source's resistance: Less than whichever is greater, ±0.2 μV/1Ω or ±0.01% / 100Ω
Maximum allowable wiring resistance for RTD input: 10 Ω/wire (The resistance values of three wires must be the same.)
 • Effect of wiring resistance: ±0.2°C / 10Ω maximum

Allowable input voltage:
 ±10 V DC for thermocouple or DC mV input
 ±20 V DC for DC V input
Noise rejection ratio (50/60Hz)
 Normal mode noise: Min. 40 dB
 Common mode noise: Min. 120 dB (Min. 90 dB for DC V input)
Error of reference junction compensation:
 ±1.5°C (at 15-35°C)
 ±2.0°C (at 0-50°C)
 The reference junction compensation cannot be switched off.
Applicable Standards:
 Thermocouple and resistance temperature detector JIS/IEC/DIN ITS90

Control Output
Output: 1 point (for general-purpose control model) or 2 points (for heating/cooling control model)
Output type:
 Choose one from (1) to (3) below:
 (1) Relay contact output
 Contact capacity: 3 A at 240 V AC or 3 A at 30 V DC (with resistance load)
 Note: The control output relay cannot be replaced by users
 (2) Voltage pulse output
 On voltage: 12-18 V DC
 Off voltage: 0.1 V DC or less
 load resistance: 600 Ω or greater
 short-circuit current: approx. 30 mA
 (3) Current output
 Output signal: 4 to 20 mA
 Maximum load resistance: 600 Ω
 Output accuracy: ±0.3% of span (at 23 ±2°C ambient temperature)

Display
Measured value and setpoint display: 7-segment LED display
Character height: See the table below.

	UT130	UT150	UT152	UT155
PV display (mm)	17.5	13.5	13.5	20.0
SP display (mm)	N/A	9.0	9.0	9.5

Status indicator lamps: LEDs
Transmission Output
 The transmission output is provided only when the /RET option is specified, but is not available for the UT130 or a heating/cooling control model.
Output signal: PV (Process value) in 4 to 20 mA DC
Maximum load resistance: 600 Ω
Output accuracy: ±0.3% of span (at 23 ±2°C ambient temperature)

Contact Inputs
 The contact inputs are provided only when the /EX option is specified, but are not available for the UT130.
Functions:
 (1) Switching over two setpoints (SP1 and SP2)
 (2) Starting a timer (See the following "Alarm Functions.")
Input type: Voltage-free contact or transistor contact input
Contact capacity: At least 12 V, 10 mA
On/off judgment: On state for 1kΩ or less; off state for 20 kΩ or greater

Alarm Functions

Alarm Functions (Option Code /AL or /HBA)
Alarm types: 22 types (Waiting action can be set by software): PV high limit, PV low limit, Deviation high limit, Deviation low limit, Deenergized on deviation high limit, Deenergized on deviation low limit, Deviation high and low limits, High and low limits within deviation, Deenergized on PV high limit, Deenergized on PV low limit, self-diagnostic alarm, failure alarm
Alarm output: 2 relay contacts
 Relay contact capacity: 1 A at 240 V AC or 1 A at 30 V DC (with resistance load)

Heater Disconnection Alarm (Option Code /HBA)
 The heater disconnection alarm is available when time-proportional PID control or on/off control is selected.
Heater current setting range: 1 to 80 A
Alarm output: 1 relay contact (The terminals are the same as those of the /AL option.)
On time of burn-out detection: Min. 0.2 second
Sensor: CTL-6-S or CTL-12-S36-8 (URD Co. Ltd.) To be purchased separately.

Timer Function (Option Code /EX/AL or /EX/HBA)
 The output contact status changes when the preset time has passed since "TMR" contact turned on. The contact action can be selected by software from:
 (1) Make contact - the contact closes upon time-up.
 (2) Break - the contact opens upon time-up.
Input contact type: See "Contact Inputs" above.

Communication Function

The communication function is provided only when the /RS option is specified.

Communication Protocol
Personal computer link: Used for communication with a personal computer, or UT link module of the FA-M3 controller (from Yokogawa Electric Corporation).
Ladder communication: Used for communication with a ladder communication module of the FA-M3, or a programmable controller of other manufacturers.
MODBUS communication: Used for communication with equipment featuring the Modbus protocol.

Communication Interface
Applicable standards: Complies with EIA RS-485
Number of controllers that can be connected: Up to 31
Maximum communication distance: 1,200 m
Communication method: Two-wire half-duplex, start-stop synchronization, non-procedural
Communication speed: 2400, 4800, or 9600 bps

Safety and EMC Standards

Safety:
 Confirms to IEC1010-1: 1990 and EN61010-1: 1992
 Approved by CSA1010 for installation category CAT II (IEC1010-1)
 Certified for UL508
EMC standards: Complies with:
 EN55011: Class A, Group 1 for EMI (emission)
 EN50082-2: 1995 for EMS (immunity)
 • All wires except those for the power supply and relay contact output terminals are shielded.
 • The controller does not fluctuate more than 20% even when noise is applied.

Construction, Mounting, and Wiring

Construction: Start-stop synchronization, non-procedural
Casing: ABS resin and polycarbonate
Case color: Black
Mounting: Flush panel mounting
Terminals: Screw terminals
Dimensions and weight: See the list of models (page. 3-4).
Panel cutout dimensions: See the rear cover.

Power Supply and Isolation

Power Supply (Common for All Models)		
Power supply	Voltage	Rated at 100-240 V AC (10% universal power supply)
	Frequency	50 or 60 Hz
Maximum power consumption	8 VA	
Memory	Non-volatile memory	
Withstanding voltage	Between primary terminals and secondary terminals (See Note 1.)	1500 V AC for 1 minute (Note 2)
	Insulation resistance	20M Ω or more at 500 V DC (See Note 1.)

Note 1: The primary terminals are the power supply terminals and relay output terminals. The secondary terminals are the analog input and output terminals, the voltage pulse output terminals, and the contact input terminals.
 Note 2: The withstanding voltage is specified as 2300 V AC per minute to provide a margin of safety.

Isolation
 Red lines below indicate reinforced isolation, and green line indicate functional isolation.

• Power supply terminals	• Measured value input terminals
• Control output terminals: relay contacts	• CT input terminals for /HBA
• Alarm output terminals (2 relay contacts)	• 2 input terminals for /EX (note 1)
	• Internal circuit (note 2)
	• Control output terminals: 4-20 mA DC output or voltage pulse (note 3)
	• RS-485 terminals for /RS

Note 1: The /EX option is not available for the UT130.
 Note 2: Neither the measured value input terminals, CT input terminals for the /HBA option, nor input terminals for the /EX option are isolated from the internal circuit.
 Note 3: The UT130 does not have the 4 to 20 mA DC output.

Environmental Conditions

Normal Operating Conditions
Warm-up time: At least 30 minutes
Ambient temperature: 0 to 50°C (0 to 40°C when mounted side-by-side)
Rate of change of temperature: 10°C/h or less
Ambient humidity: 20 to 90% RH (no condensation allowed)
Magnetic field: 400 A/m(AT/m) or less
Continuous vibrations of 5 to 14 Hz: Amplitude of 1.2 mm or less
Continuous vibrations of 14 to 150 Hz: 4.9 m/s² (0.5G) or less
Short-period vibrations: 14.7 m/s² (1.5G) for 15 seconds or less
Shock: 98 m/s² (10G) for 11 milliseconds or less
Mounting angle: Upward incline of up to 30 degrees; downward incline is not allowed.
Altitude: 2000m or less above sea level

Maximum Effects from Operating Conditions
 (1) Temperature effects
Thermocouple, DC mV and DC V input: ±2 μV/°C or ±0.02% of F.S. /°C, whichever is the larger
Resistance temperature detector: ±0.05°C/°C or less
Analog output: ±0.05% of F.S./°C
 (2) Effect from fluctuation of power supply voltage (within rated voltage range)
Analog input: ±0.2 μV/V or ±0.002% of F.S./V, whichever is the larger
Analog output: ±0.05% of F.S./V

Transportation and Storage Conditions
Temperature: -25 to 70°C
Humidity: 5 to 95% RH (no condensation allowed)
Shock: Package drop height 90 cm (when packed in the dedicated package)

Other Handy Functions

Universal Input

The UT100 series allows you to freely change the input type by software.

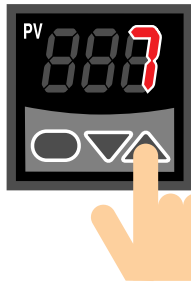

For example, to select thermocouple type E(°C), set the range code to 7.

Table 1. UT130 Input Ranges

Input Type	Range(°C)	Range Code	Range(°F)	Range Code	
Thermocouple	K	-199 to 999°C	1	-199 to 999°F	31
		0 to 600°C	2	32 to 999°F	32
		0 to 400°C	3	32 to 750°F	33
		-199 to 200°C	4	-199 to 400°F	34
	J	-199 to 999°C	5	-199 to 999°F	35
	T	-199 to 400°C	6	-199 to 750°F	36
RTD	E	-199 to 999°C	7	-199 to 999°F	37
		-199 to 900°C	12	-199 to 999°F	42
	L	-199 to 900°C	12	-199 to 999°F	42
		-199 to 400°C	13	-199 to 750°F	43
	U	-199 to 400°C	13	-199 to 750°F	43
		-199 to 850°C	15	-199 to 999°F	45
Pt100	-199 to 400°C	16	32 to 750°F	46	
	-199 to 200°C	17	-199 to 400°F	47	
	-199 to 999°C	18	-199 to 999°F	48	
	JPt100	-199 to 500°C	19		

Table 2. UT150/152/155 Input Ranges

Input Type	Range(°C)	Range Code(°C)	Range(°F)	Range Code(°F)		
Thermocouple	K	-270 to 1370°C	1	-300 to 2500°F	31	
		0.0 to 600.0°C	2	32.0 to 999.9°F	32	
		0.0 to 400.0°C	3	32.0 to 750.0°F	33	
		-199.9 to 200.0°C	4	-300.0 to 400.0°F	34	
	J	-199.9 to 999.9°C	5	-300.0 to 2100°F	35	
	T	-199.9 to 400.0°C	6	-300.0 to 750.0°F	36	
	E	-199.9 to 999.9°C	7	-300.0 to 1800.0°F	37	
	R	0 to 1700°C	8	32 to 3100°F	38	
	S	0 to 1700°C	9	32 to 3100°F	39	
	B	0 to 1800°C	10	32 to 3200°F	40	
RTD	N	-200 to 1300°C	11	-300 to 2400°F	41	
		-199.9 to 900.0°C	12	-300 to 1600°F	42	
	L	-199.9 to 900.0°C	12	-300 to 1600°F	42	
		-199.9 to 400.0°C	13	-300 to 750°F	43	
	U	-199.9 to 400.0°C	13	-300 to 750°F	43	
		0 to 1390°C	14	32 to 2500°F	44	
	Platinel 2	Pt100	-199.9 to 850.0°C	15	-199.9 to 999.9°F	45
			0.0 to 400.0°C	16	32.0 to 750.0°F	46
		JPt100	-199.9 to 200.0°C	17	-300 to 400°F	47
			-19.9 to 99.9°C	18	-199.9 to 999.9°F	48
DC voltage	0 to 100mV	0.0 to 100.0	Note	20		
	0 to 5 V	0.000 to 5.000	Note	21		
	1 to 5 V	1.000 to 5.000	Note	22		
	0 to 10 V	0.00 to 10.00	Note	23		

Note: Scalling is enable in the following 4 range.
-199.9 to 999.9, -199.9 to 999.9, -199.99 to 99.99, -1.999 to 9.999

Panel Cutout Dimensions

● UT130 and UT150 Unit: mm

General Mounting

Side-by-side Close Mounting

N is the number of controllers.
If N ≥ 5, then measure the actual length.

● UT152 Unit: mm

General Mounting

Side-by-side Close Mounting

N is the number of controllers.
If N ≥ 5, then measure the actual length.

● UT155 Unit: mm

General Mounting

Side-by-side Close Mounting

N is the number of controllers.
If N ≥ 5, then measure the actual length.

YOKOGAWA
Yokogawa M&C Corporation

World Wide Web site at http://www.yokogawa.co.jp/MCC/Welcome_e.htm

NOTICE

- Before using the product, read the instruction manual carefully to ensure proper and safe operation.

YOKOGAWA M&C CORPORATION International Operations

Kojimachi-Tokyu Bldg. 3F
6-6 Koji-machi, Chiyoda-ku, Tokyo, 102-0083 Japan
Phone: 81-3-3239-0576 Facsimile: 81-3-3239-0585

YOKOGAWA CORPORATION OF AMERICA
2 Dart Road, Newnan, GA, 30265-1094 U.S.A
Phone: 1-770-253-7000 Facsimile: 1-770-251-2088

YOKOGAWA TAIWAN CORPORATION
Fu Chi Bldg. 6th Floor, 99 Jen-ai Road,
2nd Section, Taipei, TAIWAN
Phone: 886-2-2321-1113 Facsimile: 886-2-2322-5593

YOKOGAWA EUROPE B. V.
Vanadiumweg 11, Amersfoort, 3812PX THE NETHERLANDS
Phone: 31-334-64-1611 Facsimile: 31-334-64-1610

YOKOGAWA AUSTRALIA PTY. LTD.
Centrecourt D1, 25-27 Paul Street North,
North Ryde, NSW 2113, AUSTRALIA
Phone: 61-2-9805-0699 Facsimile: 61-2-9888-1844

YOKOGAWA AMERICA DO SUL S.A.
Avenida Jurua, 149 Alphaville, Barueri/SP, 06455-010 BRAZIL
Phone: 55-11-7295-1433 Facsimile: 55-11-7295-1329

YOKOGAWA BLUE STAR LTD.
40/4 Lavelle Road, Bangalore, 560 001 INDIA
Phone: 91-80-227-1513 Facsimile: 91-80-227-4270

YOKOGAWA ENGINEERING ASIA PTE. LTD.
11 Tampines Street 92, 52887 SINGAPORE
Phone: 65-783-9537 Facsimile: 65-786-6550

LTD. YOKOGAWA ELECTRIC
Hotel International No. 2, Room 1047, Krasnopresnenskaja Nab.
12, Moscow, 123610 RUSSIAN FEDERATION
Phone: 7-095-967-0350 Facsimile: 7-502-253-3509

HANKUK YOKOGAWA ELECTRIC CO., LTD.
K. P. O. Box: 403, Chongohon-2dong, Pupyong-ku,
Inchon, KOREA
Phone: 82-32-510-3304 Facsimile: 82-32-529-6301/6302

Represented by:

MCS-EM2