

General Specifications

Model YF100 Vortex Flowmeters (Style E)

YEWFL0

GS 01F02B04-00E-A

These YF100 Vortex Flowmeters measure process fluid flow by measuring the rate at which vortices are shed from a shedder in the process flow line. Two Flowmeter versions are available : one has a built-in (integral) converter, the other - used with a remote converter - is for when the detectors is inaccessible or when high temperature process liquid, gas or steam flow is to be measured. In either case, the associated converter provides a pulse output or a 4 to 20mA DC signal proportional to flow rates.

The YF100 style E combines FOUNDATION Fieldbus(Note1), BRAIN and HART(option, Note2) communication functions with a Vortex Flowmeter.

FEATURES

- This simply structured model without moving parts excels in reliability and durability. Its flow route involves only a vortex generating body with a trapezoidal section.
- Generated vortices are detected by two piezoelectric sensor elements embedded in the shedder bar. The sensor and fluid are not in contact.
- Liquids, gases and steam can all be measured by a detector with the same structure.
- As the range of temperature and fluid pressure are wide, this model can be used for a variety of fluids.
- Output is directly proportional to volume flow rate.
- Auto-tuning function: It automatically cut noise output caused by piping vibration and is convenient for simple maintenance. To executed this function only simply press the key of HHT(BT200).
(Available from Amplifier's version 3.00)
- FEATURES of Intelligent Amplifier
- Using a hand-held terminal, (BT200 BRAIN TERMINAL or HART communication), the YF100 allows the user to remotely change flowmeter range.
- Analog signals cannot be affected by communication because AC communication signals are superimposed on analog signals of 4 to 20mA DC.
- YF100 style E communication function includes FOUNDATION Fieldbus, BRAIN and HART protocol. The items marked with * in this specification, is different for Fieldbus communication type, please refer to GS 1F2F4-E.
- It can display totalized flow, as well as instantaneous flow rates in engineering units or percent(%) of span alternatively.
- Nominal size 15 to 300mm, Liquid, Gas, Steam, Cryogenic (15 to 100mm, Option) and High process temperature (25 to 200mm, Option) service can be in the same amplifier.
- Amplifier can be converted into 4 to 20mA DC or Voltage pulse easily.



(Note 1)FOUNDATION is a registered trademark of Foundation Fieldbus .
(Note 2)HART is a registered trade mark of the HART Communication Foundation .

STANDARD SPECIFICATIONS

Fluid to be Measured: Liquid, gas or Steam (Avoid Multi-phase Flow and Sticky Fluids).

Measurable Flow Rates: Refer to Sizing Chart (Table 3).

Accuracy: (Refer to Table 3(b))

Liquid	±0.8% of Reading
Gas and Steam	±0.8% of Reading (Velocity 35m/s or less) ±1.5% of Reading (Velocity 35m/s to 80m/s)

(Note) This table shows the accuracy of Pulse Output. In case of Analog Output add up ± 0.1% of full scale to the values mentioned above.
(For Intrinsic Safety and IEC Type n add up ± 0.2%)

Repeatability: ± 0.2% of reading.

Process Temperature Limits: -40 to +300°C.

Refer to Figure 1-1 for integral converter type.
If fluid temperature is 300°C or more, High temperature version (HPT:400°C) will be recommended.

If fluid temperature is -40°C or less, Low temperature version (LPT:-200°C) will be recommended.

Process Pressure Limits: -1kg/cm²(-0.1 MPa) to flange ratings.

Ambient Temperature Limits: -40 to +80°C,
(see Figure 1-1.)

• With indicator/totalizer: -30 to +80°C

• JIS Explosion proof: -20 to +60°C

• FM Explosion proof: -40 to +60°C

• FM Intrinsic.Safety

Integral type, Remote type (Converter): -40 to +50°C

Remote type (Detector): -40 to +80°C

- CENELEC Explosion proof:
Integral type, Remote type (Converter)
: -40 to +80°C
Remote type (Detector): -40 to +80°C
- CENELEC Intrinsic Safety:
Integral type, Remote type (Converter): -40 to +50°C
Remote type (Detector): -40 to +80°C
- IEC Type n Explosion proof:
Integral type, Remote type (Converter): -40 to +50°C
Remote type (Detector): -40 to +80°C
- SAA Explosion proof: -40°C to +60°C
- SAA Intrinsic Safety:
Integral type, Remote type (Converter): -40 to +50°C
Remote type (Detector): -40 to 80°C
- CSA Explosion proof:
Integral type: -50 to T°C(See Fig1-1.)
Remote type: -50 to +80°C
- CSA Intrinsically Safe:
Integral type: -40 to +50°C
Remote type: -40 to +80°C

Ambient Humidity Limits: 5 to 100% Relative Humidity.
(no condensation)

Power Supply Voltage and Load Requirements(*):

Analog output; 20 to 42 V DC.(at 350 ohm)
See "Relationship between supply voltage and load resistance " Figure 2.

Pulse output; 14 to 30 V DC
(Input Power Supply Voltage Vs).
Maximum line capacitance; 0.22µF, (0.1µF, In case output frequency is more than 2.5kHz.)
Maximum lead wire resistance; 50 ohm

Output Signal(from converter) (*);

Analog; 4 to 20mA DC, 2 wire system.
(Delay time 0.5 seconds.)

Pulse; Voltage pulse, 3 wire system.
(Delay time 0.5 seconds.)
(Scaled and unscaled pulse)

Low level; 0 to 2V
High level; Vs - Vd (Refer to Fig.3)
(Vs:Input Power Supply Voltage, Vd: Voltage Drop)
Duty cycles;50% (max - 1 to 2 or 2 to 1)

Nominal pulse rates are shown in Table 4.

Communication Signal: FOUNDATION Fieldbus digital communication,BRAIN or HARTcommunication signal (superimposed on a 4 to 20mA DC signal)

Communication-Line Conditions (*):

- Load resistance: 250 to 600Ω
(includes cable resistance).
- BRAIN communication (see Figure 2.)
Region within communication 2km (800m is for Intrinsic Safety and IEC Type n.) (when "CEV" cables are used).
- Load capacitance: 0.22µF maximum.
- Load inductance: 3.3mH maximum.
- HART communication

Conditions of Communication Line:

Supply Voltage;
General Use & Explosion proof Type...17 to 42V DC
(Refer to Figure. 2).

Load resistance; refer to Figure.2
Minimum cable size: 24 A WG,(0.51mm diameter).
Cable type: Single pair shielded or multiple pair with overall shield.

Maximum twisted-pair length: 10,000 ft (3,048 m).
Maximum multiple twisted-pair length: 5,000 ft(1,524 m)

Use the following formula to determine cable length for a specific application:

$$L = \frac{65 \times 10^6}{(RXC)} - \frac{(C_r + 10,000)}{C}$$

Where:

- L = length in feet or meters.
- R = resistance in ohms, current sense resistance plus barrier resistance.
- C = cable capacitance in pF/ft, or pF/m.
- C_r = Maximum shunt capacitance of field devices in pF.

• BRAIN and HART communications
Communication cables must be laid at least 15 cm away from power lines. Do not lay the cables parallel to power lines.

Instruments connected for receiving resistance:
Input impedance 10k ohm or more (at 2.4kHz)

Time Constant: 0.3 sec. (with analog output).

Material:

Body; JIS SCS14 stainless steel (The flange of 250mm and 300mm are JIS SUS 304.)
Hastelloy C (equivalent to ASTM A494CW-12MW)

Shedder bar; Duplex stainless steel (DCS1, only for 15 mm is DSD1-H, Both equivalent to JIS SUS329J)

Hastelloy C (equivalent to ASTM A494CW-12MW)
(Note) DSC1 and DSD1-H are registered trademarks of Daido Tokushu Steel Co.

Gasket; JIS SUS316 stainless steel with polytetrafluoroethylene (Teflon) coating.

Flowmeter Housing and Covers; Aluminum alloy.

Coating Color:

Frosty white (Polyurethane resin coating)
.....Converter case
Deep sea moss green (Polyurethane anticorrosion coating)Converter cover

Mounting:

Flowmeter can be installed vertically, horizontally or at any other angle. For liquid service, the flow line must be filled with the liquid.

Vortex Flow Detector:

Flange mounting or wafer mounting by flanges of adjacent pipeline.

Vortex Flow Converter:

(Remote converter type): 50mm, (2 inch) pipe mounting.

Enclosure Classification:

Designed to meet JIS C0920 Watertight (equivalent to IEC IP67, NEMA 4X).

Electrical Classification:• **JIS Explosion proof**

certified for Ex d II B+H2 T6X.

• **FM Explosion proof**

Explosionproof for: Class I, Division 1, Group B, C and D.

Dust ignitionproof for: Class II, Division 1, Groups E,F and G.

Suitable for: Class III, Division 1

Temperature Class: T6

Outdoor NEMA Type 4 Hazardous location.

• **FM Intrinsically Safe**

Intrinsically Safe for use in Class I,II,III,Division 1, Group A,B,C,D,E,F and G

No. IFM011-A12

Nonincendive for Class I, Division 2, Group A,B,C and D

No. IFM011-A12

Suitable for Class II,III,Division 2, Group F and G hazardous indoor/outdoor (NEMA 4) locations

Analog output : Vmax = 28V DC

I_{max} = 93mA, P_{max} = 0.66W

C_i = 4nF, L_i = 1.1mH

Pulse output : Vmax = 28V DC

I_{max} = 93mA, P_{max} = 0.66W

C_i = 62nF, L_i = 1.1mH

Temperature class :T5

• **CENELEC Explosion proof**

KEMA No.: Ex-93.C.7708

EEx d II C T6...T1

• **CENELEC Intrinsic Safety**

KEMA No.: Ex-93.C.8205

EExib IIC T6...T1,

Maximum voltage V_{max} = 28V

Maximum current I_{max} = 93mA

Internal inductance L_{int} = 1.1mH

Internal capacitance C_{int} = 6nF

• **IEC Type n Explosion proof**

KEMA No.: Ex-95.Y.3507

Ex nA II C T6

• **SAA Explosion proof**

Certificate No. AUS Ex 1303

Ex d IIB T6 IP65

• **SAA Intrinsic Safety**

Certificate No. AUS Ex 3076X

EX ib IIC T6 IP65

Ex n IIC T6 E7 IP65

Maximum voltage V_{max} = 28V

Maximum current I_{max} = 93mA

Maximum power P_{max} = 0.66W

Internal inductance L_{int} = 1.1mH

Internal capacitance C_{int} = 6nF

• **CSA Explosion proof**

Application No.LR81741C

Explosion proof ClassI, Division 1, Groups C&D

Dust-ignition proof ClassII, Division 1, Groups E,F&G

Suitable for ClassIII, Division 1

When installed in ClassI, Division 2-LEADS

FACTORY SEALED

Temperature Class T6...T2

Outdoor Rating Encl.4

• **CSA Intrinsically Safe type**

Certificate No.LR81741C

Intrinsically Safe for Class I, Groups A,B,C&D;

Class II, Groups E,F&G;When connected as per

YOKOGAWA Drawing Number ICS002-A12 P1,

Suitable for use in Class I, Div.2, Groups A,B,D&D:

Class II, Div.2, Groups E,F &G:

Class III HAZARDOUS LOCATIONS.

Group F Dust Resistance must be greater than

100.000 ohms per centimeter.

Enclosure "Type4".

Temperature class;

Integral type T5...T1

Remote type T5...T1

Maximum Voltage V_{max}=28V DC

Maximum Current I_{max}=93mA

Internal Capacitance C_i=6nF

Internal Inductance L_i=1.1mH

Electrical Connection: JIS G1/2 female (the same as G1/2 in ISO R228), ANSI 1/2 NPT female, ISO M20X1.5 female, or DIN Pg 13.5 female.

Signal Cable: Model YF011 cable, used for remote detector and converter. Maximum length is 20m. Outer Sheath Material; Black heat resistance polyethylene Durable Temperature; -40 to +150°C

MASS: Refer to External Dimensions.

Calibration: These flowmeters are factory-calibrated using water flow.

Functions (Only available for combining with BT200):

Instrument Error Correction: YF100 Vortex Flowmeter instrument errors can be corrected by segment approximations (using 5 correction factors).

Damping adjustment: 0,2,4,8,32 or 64 seconds can be set. (Default Value: 4sec)

*Delay Time : 0.5sec.

*Time Constant : 4sec.(with analog output)

Remote Reset Functions: Totalizer values on the flow indicator can be reset.

Other corrections: Reynolds Number correction, Adjacent pipe effect correction, Gas expansion factor correction.

• **EMC Conformity Standards**

EMI : EN55011 Class A Group 1

EMS : EN50082-2

AS/NZS 2064 : 1997

Note:

1. For pulse output type, the shielded type wire should be used for power supply cable.
2. For remote converter type, the signal cable should be used with the metal conduit.

• **Refer to P.12 and P.13 for installation of this Vortex flowmeter.**• **Pressure Loss:**

At velocity of 10m/s by water, $\Delta P = 1.1\text{kg/cm}^2$.

At velocity of 80m/s by atmospheric air,

$$\Delta P = 910\text{mmH}_2\text{O}.$$

obtained from the following equations.

$$\Delta P = 1.1 \times 10^{-5} \cdot p \cdot f \cdot V^2$$

or

$$\Delta P = 1.3377 \times pf \cdot \frac{Q^2}{D^4}$$

where,

- ΔP : Pressure loss (kg/cm²)
- ρ_f : Density at operating condition (kg/cm³)
- V : Flow velocity (m/s)
- Q : Actual flow rate (m³/h)
- D : Internal Diameter (mm)

Figure 4 shows pressure loss versus actual flow rate. When nominal size 15 to 50mm and adjacent pipeline is Sch 40, and nominal size 80 to 300mm and adjacent pipeline is Sch 80, the pressure loss will be approximately 10% smaller than calculated value.

• Cavitation

(Minimum Back Pressure, Liquid service only):

Confirm that the flow line pressure is sufficiently high, so as to no cavitation occurs. The optimum line pressure can be obtained from the following equation.

$$P = 2.7 \cdot \Delta P + 1.3 \cdot P_o$$

Where,

- P : Line pressure, 2 to 7 times as large as internal diameter on downstream of flowmeter body surface. (kg/cm² absolute).
- ΔP : Pressure loss (kg/cm²). Refer to the item above.
- P_o : Saturation liquid vapor pressure at operating temperature (kg/cm² absolute).

Example

- Water Flow Rate : 0 to 50 m³/h
- Density : 992.2kg/m³
- Operating Pressure : 0.5kg/cm²G
- Operating Temperature : 40°C
- Flowmeter Size : 50mm (2 inch)

(Solution)

$$\Delta P = 1.377 \times 992.2 \times \frac{50^2}{51.1^4}$$

$$= 0.501 \text{ kg/cm}^2$$

$$P = 2.7 \times 0.501 + 1.3 \times 0.07252$$

$$= 1.450 \text{ kg/cm}^2 \text{ absolute}$$

$$= 1.450 - 1.0332 = 0.417 \text{ kg/cm}^2 \text{G}$$

Since the operating pressure of 0.5kg/cm²G is higher than 0.417kg/cm²G, no cavitation occurs.

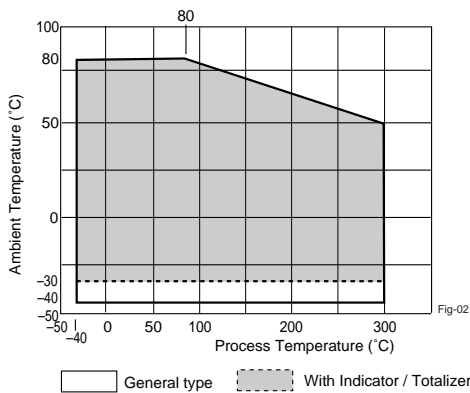

Figure 1-1. Ambient Temperature Limit (Integral Converter Type)

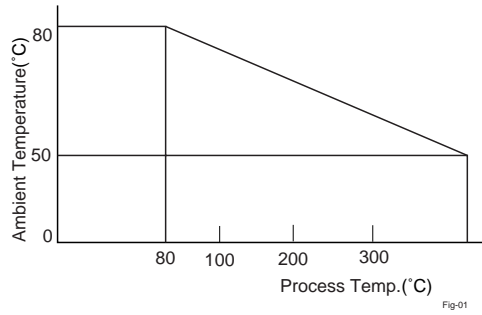

Figure 1-2. Ambient Temperature Limit (Only for CSA Explosion Proof Type)

■ Analog

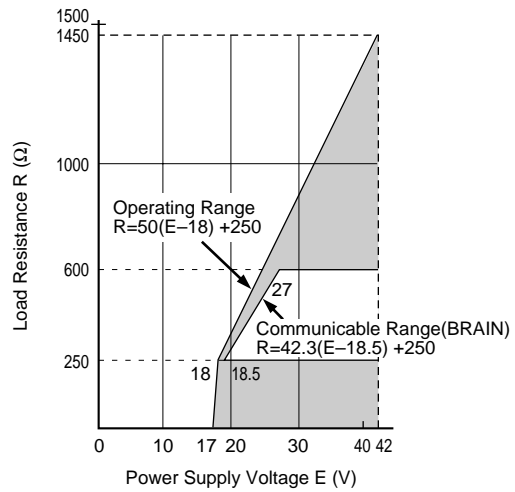

Figure 2-1. Relationship between Supply Voltage and Load Resistance (Analog output)

■ Intrinsic Safety • Analog

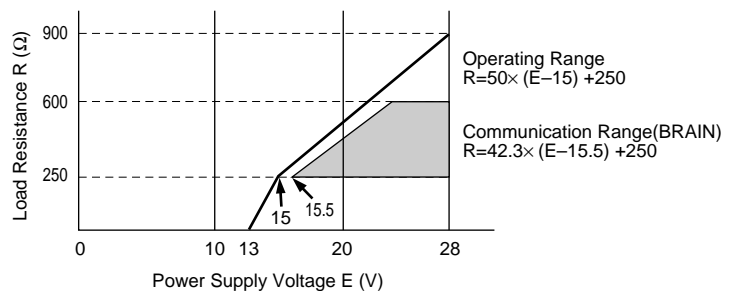

Figure 2-2. Relationship between Supply Voltage and Load Resistance (Analog output for Intrinsic Safety)

■ IEC Type n • Analog

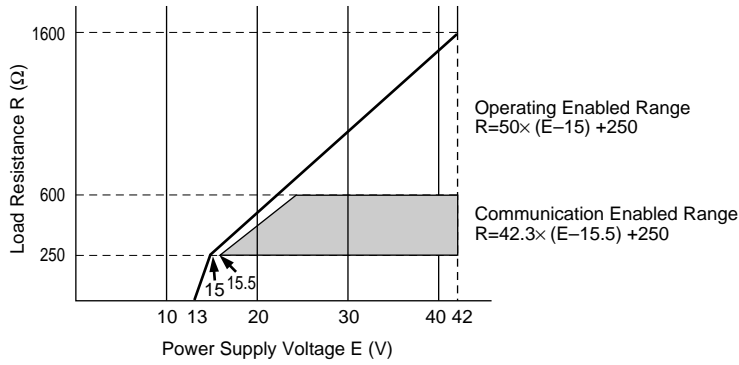

Figure 2-3. Relationship between Supply Voltage and Load Resistance (Analog output for IEC Type n)

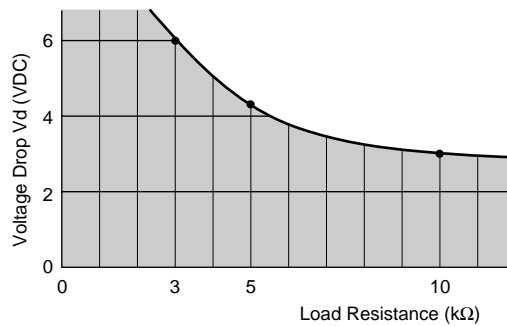

Figure 3. Load Resistance vs. Voltage Drop

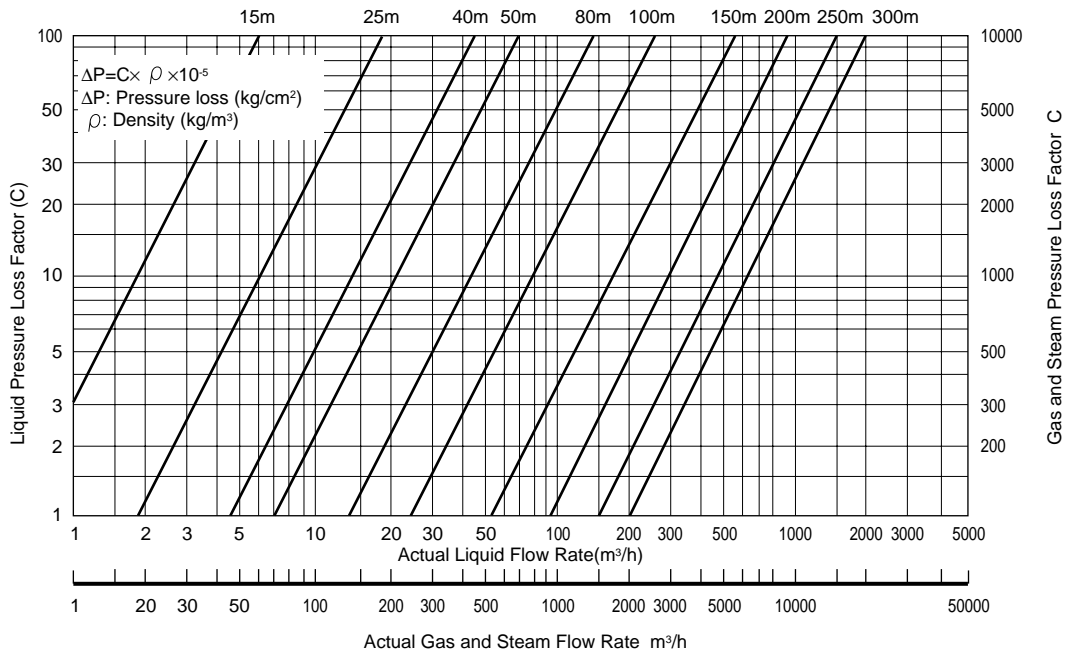

Figure 4. Pressure Loss

Model and Suffix Codes
YF100 Vortex Flowmeters

Model	Suffix Code	Description	
YF101		Size 15 mm (1/2 inch)	
YF102		Size 25 mm (1 inch)	
YF104		Size 40 mm (1-1/2 inch)	
YF105		Size 50 mm (2 inch)	
YF108		Size 80 mm (3 inch)	
YF110		Size 100 mm (4 inch)	
YF115		Size 150 mm (6 inch)	
YF120		Size 200 mm (8 inch)	
YF125		Size 250 mm (10 inch)	
YF130		Size 300 mm (12 inch)	
Converter and Output Signal *9 *13	-AA	Integral type Liquid, Gas, Steam Digital communication (FOUNDATION Fieldbus protocol)	
	F	4 to 20 mA DC, Pulse Brain Communication Intrinsic Safety	
	U	4 to 20 mA DC Brain Communication Intrinsic Safety	
	D	4 to 20 mA DC Brain Communication Intrinsic Safety Pulse	
	R	Remote converter type	
Process *1 Connection	J1	JIS 10 kg/cm ² flange	
	J2	JIS 20 kg/cm ² flange	
	J3	JIS 40 kg/cm ² flange *1	
	A1	ANSI Class 150 flange	
	A2	ANSI Class 300 flange	
	A3	ANSI Class 600 flange *1	
	D1	DIN PN10 flange	
	D2	DIN PN16 flange	
	D3	DIN PN25 flange	
	D4	DIN PN40 flange	
	D5	DIN PN64 flange	
	D6	DIN PN100 flange	
	M1	JPI CLASS150	
	M2	JPI CLASS300	
	M3	JPI CLASS600	
	K1	JIS 10 kg/cm ² wafer	
	K2	JIS 20 kg/cm ² wafer	
	K3	JIS 40 kg/cm ² wafer	
	B1	ANSI Class 150 wafer	
	B2	ANSI Class 300 wafer	
	B3	ANSI Class 600 wafer	
	E1	DIN PN10 wafer	
	E2	DIN PN16 wafer	
	E3	DIN PN25 wafer	
	E4	DIN PN40 wafer	
	H1	JPI CLASS150 wafer	
	H2	JPI CLASS300 wafer	
	H3	JPI CLASS600 wafer	
	Electrical Connection *2	J	JIS G 1/2 Female
		A	ANSI 1/2 NPT Female *3
		D	DIN Pg 13.5 Female
		M	ISO M20x1.5 Female
	Vortex Shedder Body Material	-S3S3	Stainless Steel
-HCHC		Hastelloy C	
Style Code	*E	Style E *6	
Electrical Classification *3,4,10,11,12	/JF3	JIS Explosion proof (Flame proof)	
	/FMF	FM Explosion proof	
	/FMS	FM Intrinsic Safety	
	/CEF	CENELEC Explosion proof	
	/CES	CENELEC Intrinsic Safety and IEC Type n	
	/SAF	SA A Explosion proof	
	/SAS	SA A Intrinsic Safety	
	/CSF	CSA Explosion proof	
/CSS	CSA Intrinsically Safe		
Options	/□ /□		

- *1 : In case of Size 250 and 300 mm (8, 10, 12 inch), JIS 40kg/cm² and ANSI Class 600 are not available. And in case of Size 200 mm (8 inch), JIS 40 kg/cm² is not available.
- *2 : ANSI 1/2 NPT female or DIN Pg 13.5 is available for /JSF by special order procedure.
- *3 : In the case of / FMF or /CEF, gauge depth limit is +0.5 to +3.5 turns deeper than ANSI standards to match FM Explosionproof.
- *4 : In case of JIS Flameproof (/JF3), specify in the option code with Flame proof packing ground (/G□) for the cable wire construction. In case the ambient temperature exceeds 50deg.C, use heat resistant cables with maximum allowable temperature of 70degC or above.
- *6 : Vortex Flow detector is the same as style D.
- *8 : Nominal size, output (4 to 20mA DC or Pulse), Fluid (Liquid, Gas or, Steam), Density, Viscosity, Pressure, Temperature, Flow range, Parameters are set at the factory before shipment.

Tab-03

Table 1. Flowmeter Selection Guide

Nominal Size mm (inch)		15 (1/2)	25(1)	40(1-1/2)	50(2)	80(3)	100(4)	150(6)	200(8)	250(10)	300(12)
Process Connection	Stainless Steel	Wafer Type	YES	YES	YES	YES	YES	NO	NO	NO	NO
		Frang Type	YES	YES	YES	YES	YES	YES	YES	YES	YES
	Hastelloy C	Wafer Type	YES	YES	YES	YES	NO	NO	NO	NO	NO

Tab-05

YFA11 Vortex Flow Converter (Remote type)

Model	Suffix Code	Description
YFA 11		Vortex Flow Converter
Fluid and Output Signal *9 *13	-A	Liquid, Gas, Steam Digital communication (FOUNDATION Fieldbus protocol)
	F	4 to 20 mA DC, Pulse Brain Communication Intrinsic Safety
	U	4 to 20 mA DC Brain Communication Intrinsic Safety
	D	4 to 20 mA DC Brain Communication Intrinsic Safety Pulse
	R	2 inch Pipe Mounting
Mounting	P	2 inch Pipe Mounting
Electrical Connection *2	J	JIS G 1/2 Female
	A	ANSI 1/2 NPT Female *3
	D	DIN Pg 13.5 Female
	M	ISO M20x1.5 female
Flowmeter Nominal Size	-01	15 mm (1/2 inch)
	-02	25 mm (1 inch)
	-04	40 mm (1-1/2 inch)
	-05	50 mm (2 inch)
	-08	80 mm (3 inch)
	-10	100 mm (4 inch)
	-15	150 mm (6 inch)
	-20	200 mm (8 inch)
	-25	250 mm (10 inch)
	-30	300 mm (12 inch)
Style Code	*E	Style E
Electrical Classification *3,4,10,11,12	/JF3	JIS Explosion proof (Flame proof)
	/FMF	FM Explosion proof
	/FMS	FM Intrinsic Safety
	/CEF	CENELEC Explosion proof
	/CES	CENELEC Intrinsic Safety and IEC Type n
	/SAF	SA A Explosion proof
/SAS	SA A Intrinsic Safety	
/CSF	CSA Explosion proof	
/CSS	CSA Intrinsically Safe	
Options	/□ /□	

YF011 Signal Cable (Remote type)

Model	Suffix Code	Description
YF011		Single Cable *7
Cable	-0	Without End finish *5
	-1	Without End finish
Cable Length	-05	5m
	-10	10m
	-15	15m
	-20	20m
Style Code	*E	Style E
Options	/C□	With cable end finish part. An entered digit shows required set quantity. Only for YF011-0

- * 5 : One set of end finish parts is attached.
- * 7 : Signal cable is the same as style D.
- * 9 : When parameter B02 is set for a pulse output, the BRAIN or HART communication is not available. The parameters can only be set or read by connecting BRAIN or HART communication and amplifier.
- *10 : /CEF, and /CES are available for DIN Pg 13.5, ISO M20x1.5, or ANSI 1/2 NPT.
- *11 : /SAF, and /SAS are available for ANSI 1/2 NPT or ISO M20x1.5.
- *12 : ANSI 1/2 NPT is available for /FMS, /CSF and /CSS.
- *13 : FOUNDATION Fieldbus communication model is not applicable to intrinsically safe type and the remote type confirmed to EMC standards.

Tab-04

Option Specifications

Item	Specification	Code
Built-in indicator/Totalizer (Instantaneous flow (% or engineering units) or totalized flow or alternate display of two selections.)	Six-digit LCD display with back-light. Totalizer value is protected by an EEPROM at the time of a power failure. It can be turned in 90 degree revolution. Mass:0.4kg additional. When intrinsic safety and IEC Type n are selected, back light does not light. Display unit: %, l, t, Nm ³ , m ³ , kg, scf, gal, lb, /h, /m	/TBL
Stainless steel tag plate	SUS304 tag plate, hung on case.	/SCT
Flameproof Packing Adapter	Power source connection port and signal cable (remote type) connection port. JIS G1/2 female thread. Other cable shape: φ 8 to φ 12. G11 : One piece, G12 : Two pieces	/G11 /G12
Stainless steel bolt & nut assembly	SUS304 bolt/nut assembly. Used when a wafer type is installed for a process.	/BLT
Paint color change	Only for converter covers: See GS 22DF1.	/SCF- □ P
HART Communication (Note 1)	Communication with HART communicator.	/HART
Material Certificate	Reproduced material certificated for body and shedder bar from material manufacture. Available for the YEFWLO standard material.	/M01
Static Pressure and Leakage test Certificate	Using hydraulic or nitrogen pressure according to the table 2.	/T01
Degrease Treatment (Note 2)	All wet parts are assembled after degreasing for stainless body. After flow calibration, the body is cleaned by trichloroethylene.	/OSW
Epoxy Coating	Epoxy coating for meter cover and case.	/EPF
High Process Temperature Version (Note 3)	This specification temperature is from -40 to +400°C. Size 25 to 200mm (1 to 8 inch) are available. If the case of another size, please ask us. Refer to figure 5 and 7.	/HPT
Cryogenic Version (Note 4)	This specification temperature is from -200 to +40°C. Size 15 to 100mm (1/2 to 4 inch) are available. If the case of another size, please ask us. Refer to figure 6.	/LPT
Stainless steel Bracket for YFA11	The bracket material for YFA11 is SUS304.	/SBK
Converter 180° reversal	The converter, YF100 integral type, is installed 180° reversal before shipment.	/CRC
GOST Certificate	Calibration Certificate for GOST(only for products produced at YFT)	/GOS

- (Note 1) HART Communication is available for CENELEC Intrinsic Safety, FM Intrinsic Safety and CSA Intrinsically safe.
 (Note 2) There is a case that calibration water should stay between the body and the shedder bar. So this is not degrease treatment in the strict sense.
 (Note 3) High Process Temperature Version is not available for Hastelloy C.
 Refer to figure 5 about fluid temperature condition, and figure 7 about minimum measurable flow velocity.
 Gasket material: JIS SUS316 stainless steel plated with silver.
 (Note 4) Cryogenic Version is not available for Hastelloy C.
 Refer to figure 6 about fluid temperature condition.
 Shedder bar material: JIS SUS14 stainless steel (JIS SUS316 stainless steel only for 15mm)

Tab-06

Table 2. Pressure test value

Flange Rating	Pressure
JIS 10K	2.1MPa(21kgf/cm ²)
JIS 20K	5.0MPa(51kgf/cm ²)
JIS 40K	10.0MPa(102kgf/cm ²)
ANSI Class 150	2.9MPa (29kgf/cm ²)
ANSI Class 300	7.5MPa(76kgf/cm ²)
ANSI Class 600	14.9MPa(152kgf/cm ²)

Tab-07

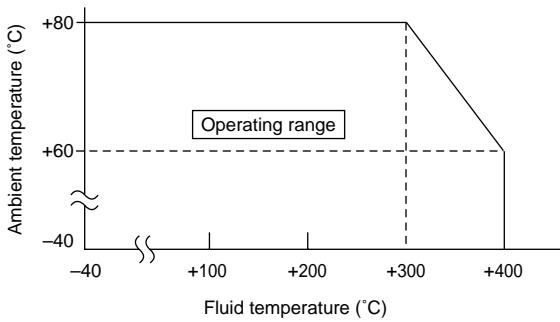

Figure 5. Fluid temperature range of high process temperature version

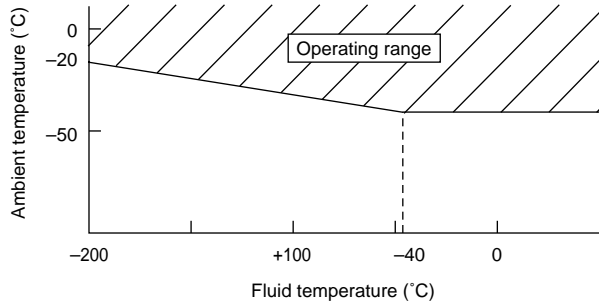

Figure 6. Fluid temperature range of cryogenic version

Sizing

- Measurable minimum flow velocity:
 - Larger value of flow velocity obtained from "relationship between the minimum flow velocity and specific weight <Figure 7(a), (b)>" or "at the velocity of a Reynolds number limit of 5000 or more", whichever is greater.
 - For liquid measurement; use <Figure 7(a)> and find the minimum velocity and "relationship between Reynolds number and minimum flow velocity <Figure 8>" can be used.
 - For Gas or Steam measurement; use <Figure 7(b)> and find the velocity, and calculate the velocity at a Reynolds number of 5000.
- Guaranteed accuracy at minimum flow velocity:
 - Nominal Size 15 to 100 mm
 - Larger value of flow velocity obtained from "relationship between the minimum flow velocity and specific weight <Figure 7(a), (b)>, or "at the velocity of a Reynolds number limit of 20000 or more", whichever is greater.
 - Nominal Size 150 to 300 mm
 - Larger value of flow velocity obtained from "relationship between the minimum flow velocity and specific weight <Figure 7(a), (b)>, or "at the velocity of a Reynolds number limit of 40000 or more", whichever is greater.
 - For liquid measurement;
 - Use the <Figure 8> of the relationship between Reynolds number and minimum velocity to obtain minimum velocity.
 - The value is four times when the Reynolds number is 20000, and eight times when the Reynolds number is 40000.
 - The method of calculating the measurable minimum flow velocity and guaranteed accuracy at minimum flow velocity are shown in Table 3(a) and Table 3(b).

- When the flow velocity is lower than minimum either the analog output or the pulse output is displayed as zero "0".

- How to calculate volume flow rate at operating conditions.

- $Q_f = \frac{v \times D^2}{354}$ or $Q_f = 3600 \times v \times S$

- How to calculate the velocity of a Reynolds number of 5000.

- $v = 5 \times \frac{V}{D}$

- $Re = \frac{354 \times 10^3 \times Q_f}{V \times D}$

- $V = \frac{V}{\rho f} \times 10^3$

Q_f : Volume flow rate at operating conditions (m³/h)

D : Inner diameter of YEFWLO (mm)

v : Flow velocity (m/s)

S : Sectional area of YEFWLO (m²)

Re : Reynolds number (none unit)

ρf : Density at operating conditions (kg/m³)

μ : Viscosity at operating conditions (cp)

ν : Kinematic viscosity at operating conditions (cSt)

Table 3(a). Range of Measurable Flow Velocity

	Minimum flow velocity	Maximum flow velocity
Liquid	Larger value of flow velocities obtained from Figure 7 and Figure 8(Reynolds number 5000).	10m/s
Gas, Steam	Larger value of flow velocities obtained Figure 7 and calculated flow velocity at Reynolds number 5000.	80m/s

Table 3(b). Accuracy Guaranteed Flow Velocity Range.

	Minimum flow velocity	Maximum flow velocity
Liquid	(1) 15 to 100 mm Larger value of flow velocities obtained from Figure 7 and calculated flow velocity at Reynolds number 20000.	10m/s
Gas, Steam	(2) 150 to 300 mm Larger value of flow velocities obtained from Figure 7 and calculated flow velocity at Reynolds number 40000.	80m/s

■ Liquid (Minimum)

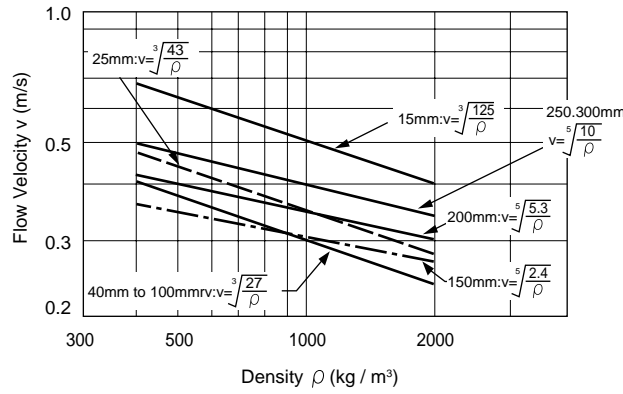

Figure 7 (a)-1. Relationship between Minimum Velocity and Density (pf:400kg/m³ or more, standard)

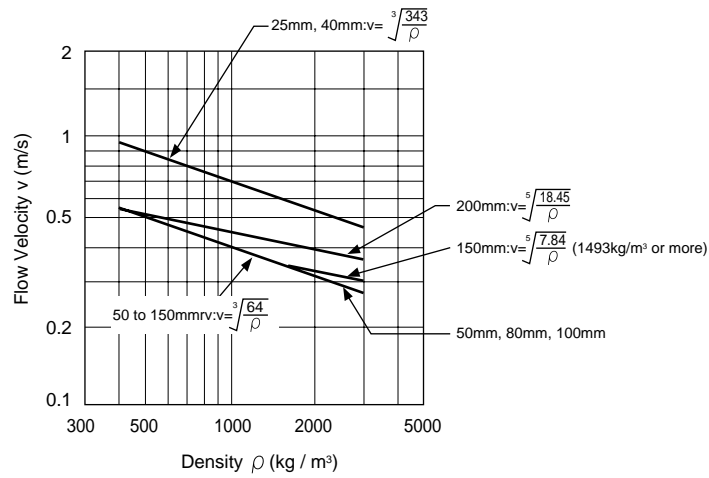

Figure 7 (a)-2. Relationship between Minimum Velocity and Density (pf:400kg/m³ or more, High process temperature version)

■ Gas & Steam (Minimum)

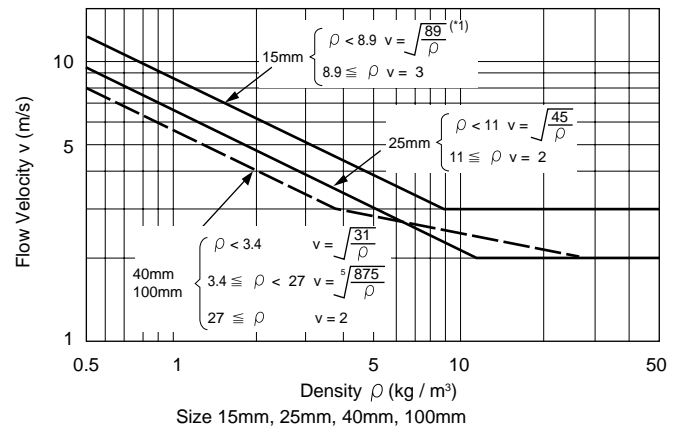
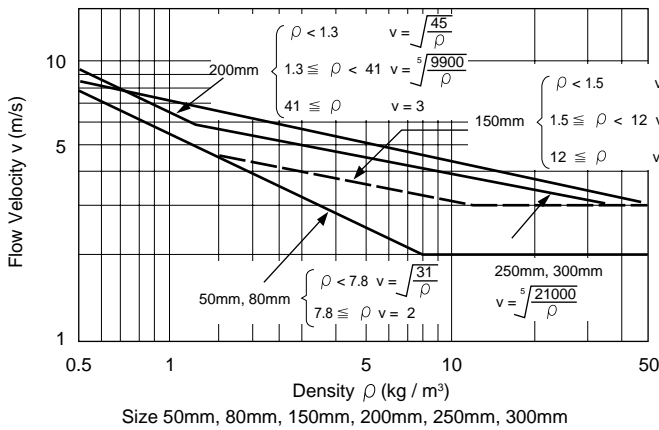

Figure 7 (b)-1. Relationship between Minimum Velocity and Density (pf:0.5kg/m³ or more, standard)

*1. In case of Intrinsic Safety and IEC Type n.
 15mm { ρ < 11.2kg/m³, v = √[101/ρ]
 ρ ≥ 11.2kg/m³, v = 3

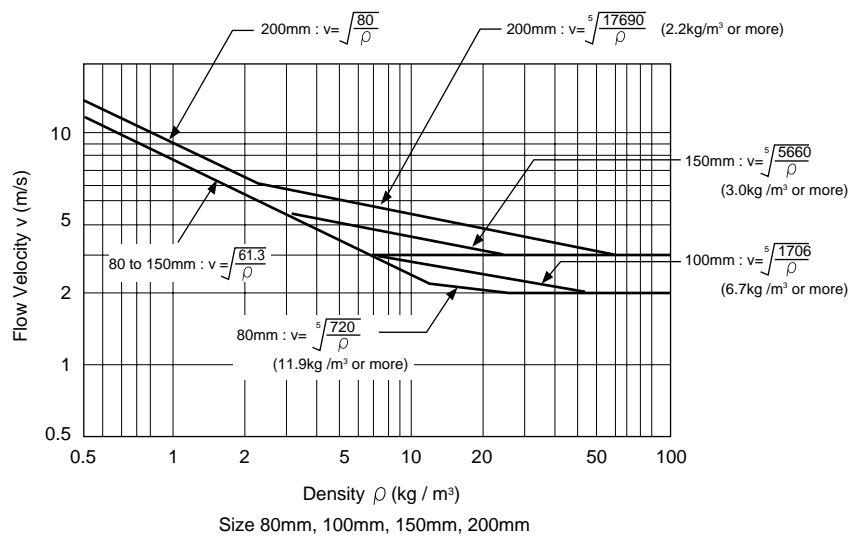
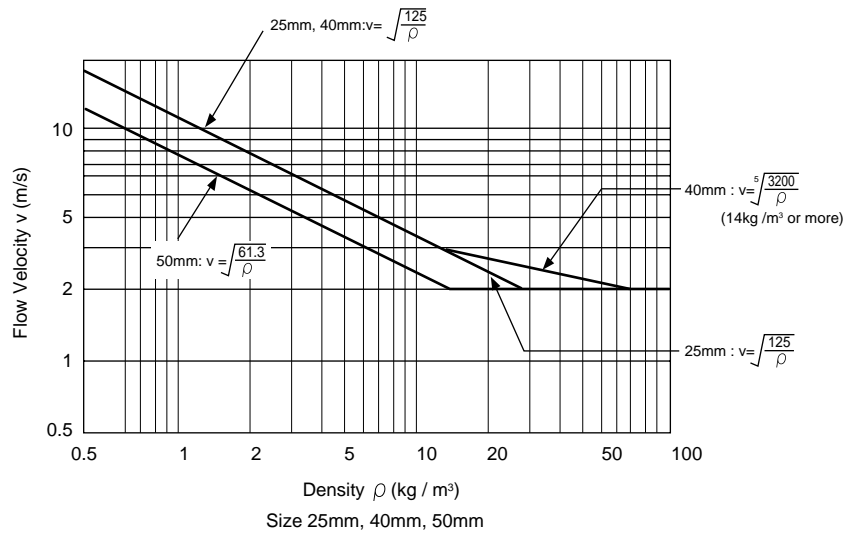

Figure 7 (b)-2. Relationship between Minimum Velocity and Density (rf:0.5kg/m³ or more, High process temperature version)

■ Liquid (Minimum) (Reynolds Number of 5,000)

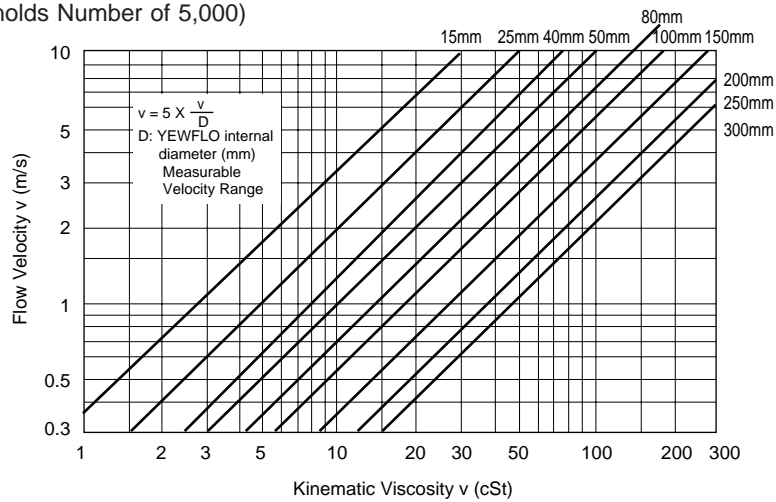

Figure 8. Relationship between Velocity and Kinematic Viscosity

Table 4. Nominal Pulse Rate and K-Factor

Nominal Size		Internal Diameter mm	Nominal K-Factor Pulse/L	Nominal Pluse Rate	
mm	inch			Hz/m/s	Hz/m ³ /h
15	1/2	14.6	376	62.7	104
25	1	25.7	65.6	35.5	19.1
40	1-1/2	39.7	18.7	23.1	5.19
50	2	51.1	8.95	18.3	2.49
80	3	71.0	3.33	13.2	0.925
100	4	93.8	1.43	9.88	0.397
150	6	138.8	0.441	6.67	0.123
200	8	185.6	0.185	5.00	0.0514
250	10	230.8	0.0966	4.04	0.0268
300	12	276.2	0.0563	3.37	0.0156

Table 5. Water Flow Rate
(At standard conditions of 15°C, ρ = 1000kg/m³)

Nominal Size		Measurable Flow Rate in m ³ /h	Normal Operating Flow Rate in m ³ /h
mm	inch		
15	1/2	0.30 to 6	0.94 to 6
25	1	0.65 to 18	1.7 to 18
40	1-1/2	1.3 to 44	2.6 to 44
50	2	2.2 to 73	3.3 to 73
80	3	4.3 to 140	4.6 to 140
100	4	7.5 to 245	7.5 to 245
150	6	17 to 540	18 to 540
200	8	34 to 970	34 to 970
250	10	60 to 1500	60 to 1500
300	12	86 to 2150	86 to 2150

Table 6. Air Flow Rate at Selected Process Pressures

Nominal Size	Flow Rate Limits	Minimum and Maximum Measurable Flow Rate in Nm ³ /h									
		0 MPa	0.1 MPa	0.2 MPa	0.4 MPa	0.6 MPa	0.8 MPa	1 MPa	1.5 MPa	2 MPa	2.5 MPa
15mm	min.	4.8(11.1)	6.7(11.1)	8.2(11.1)	10.5(11.1)	12.5	16.1	19.7	28.6	37.5	46.4
	max.	48.2	95.8	143	239	334	429	524	762	1000	1238
25mm	min.	11.0(19.5)	15.5(19.5)	19.0(19.5)	24.5	29.0	33.3	40.6	59.0	77.5	95.9
	max.	149	297	444	739	1034	1329	1624	2361	3098	3836
40mm	min.	21.8(30.0)	30.8	39.3	59	77.2	94.3	111	149	186	229
	max.	367	708	1060	1764	2468	3171	3875	5634	7394	9153
50mm	min.	36.2(38.7)	51	62.4	80.5	102	131	161	233	306	379
	max.	591	1174	1757	2922	4088	5254	6420	9335	12249	15164
80mm	min.	69.8	98.4	120	155	197	254	310	451	591	732
	max.	1140	2266	3391	5642	7892	10143	12394	18021	23648	29274
100mm	min.	122	172	219	329	431	526	618	833	1036	1277
	max.	1990	3954	5919	9847	13775	17703	21632	31453	41274	51095
150mm	min.	267	440	607	912	1193	1458	1776	2583	3389	4196
	max.	4358	8659	12960	21561	30163	38765	47367	68871	90375	111880
200mm	min.	575	1009	1393	2094	2739	3347	3929	5301	6589	7815
	max.	7792	15482	23172	38552	53933	69313	84693	123144	161595	200046
250mm	min.	1047	1814	2504	3763	4922	6016	7063	9528	11842	14047
	max.	12049	23941	35833	59617	83400	107181	130968	190427	249887	309346
300mm	min.	1500	2597	3586	5389	7049	8616	10114	13645	16959	20117
	max.	17256	34286	51317	85377	119438	153499	187560	272712	357865	443017

- (1) At standard conditions STP (0°C, 1atm).
- (2) Pressure listed is at process temperature of 0°C.
- (3) Maximum flow rate is the lower of 80 m/s.
- (4) Minimum values are determined from Figure 7(b). The values in parenthesis show the minimum linear flow rates (Re = 20,000 or 40,000) when they are higher than the minimum measurable flow rate.

Table 7. Saturated Steam Flow Rate at Selected Process Pressures

Nominal Size	Flow Rate Limits	Minimum and Maximum Measurable Flow Rate in kg/h									
		0.1 MPa	0.2 MPa	0.4 MPa	0.6 MPa	0.8 MPa	1 MPa	1.5 MPa	2 MPa	2.5 MPa	3 MPa
15mm	min.	5.9(10.7)	7.0(11.1)	8.8(11.6)	10.4(12.1)	11.6(12.3)	12.8	15.3	19.1	23.6	28.1
	max.	55.8	80	129	177	225	272	390	508	628	748
25mm	min.	13.4(18.9)	16.2(20.0)	20.5	24.1	27.1	30	36	41	49	58
	max.	169.7	247.7	400	548	696	843	1209	1575	1945	2318
40mm	min.	26.5(29.2)	32	40.6	49.0	59.2	69	92	114	135	155
	max.	405	591	954	1310	1662	2012	2884	3759	4640	5532
50mm	min.	43.9	53	67.3	79	89	98	120	156	192	229
	max.	671	979	1580	2170	2753	3333	4778	6228	7668	9166
80mm	min.	84.6	103	130	152	171	189	231	301	371	442
	max.	1295	1891	3050	4188	5314	6434	9224	12024	14842	17694
100mm	min.	148	179	227	273	330	385	514	635	751	865
	max.	2261	3300	5324	7310	9276	11230	16099	20986	25904	30883
150mm	min.	324	401	587	757	915	1067	1423	1759	2127	2536
	max.	4951	7226	11658	16007	20310	24589	35250	45953	56720	67624
200mm	min.	697	920	1348	1737	2101	2448	3266	4038	4778	5500
	max.	8853	12920	20845	28620	36315	43966	63029	82165	101418	120913
250mm	min.	1221	1652	2422	3121	3776	4400	5870	7257	8588	9885
	max.	13690	19980	32234	44257	56157	67988	97466	120758	156831	186978
300mm	min.	1749	2366	3469	4470	5408	6302	8406	10393	12300	14156
	max.	19606	28613	46162	63381	80423	97367	139582	18196	224599	267772

(1) Maximum flow rate is the lower of 80 m/s.

(3) Minimum values are determined from Figure 7(b). The values in parenthesis show the minimum linear flow rates (Re = 20,000 or 40,000) when they are higher than the minimum measurable flow rate.

Remarks on Installation

- Piping support: If pipeline vibration exist, support the pipeline.
- Installation direction: If a pipe is always filled with liquids and Reynolds number is 2×10^4 or above, the pipe can be installed vertically or at inclined angle.
- Adjacent pipes: Sch 40 pipes are recommended. When Sch10 or Sch80 pipes, it can be corrected by the pipe effect correction that YEFWLO has.
- Valve Position and Straight Pipe Length:
 - (1) In general, install the YEFWLO on the upstream side of valve. (Refer to Figure 9.1.1)
 - (2) In case of installing a valve on the upstream side of YEFWLO.
For a gas line which uses a position-type or roots-type blower compressor or a high-pressure liquid line about 1MPa(10kg/cm²) or more which uses piston-type or plunger pump, fluid vibrations may be produced.
In this case, install valve on the upstream side of YEFWLO. (Refer to Figure 9.1.2)
 - (3) In addition, install a fluid vibration damping device such as throttling plate or expansion section on the upstream side of YEFWLO. (Refer to Figure 9.1.3)
- (4) Piston-type or plunger pump; Install the accumulator on the upstream side of YEFWLO to reduce fluid vibrations. (Refer to Figure 9.1.4)
- Intensity of Fluid Vibration and expected error: When Fluid vibration may occur in the pipe line, consider the velocity fluctuation.
 - (1) Velocity fluctuation ratio $\Delta V/V < 20\%$; Measurable at error of -1% or less.
 - (2) Velocity fluctuation ratio $\Delta V/V > 40\%$; Not measurable due to occurrence of Vortex signal turbulent or noise of fluid vibration frequency.
 - (3) Velocity fluctuation ratio $20\% < \Delta V/V < 40\%$; Maximum error will occur around -10%.
(V: Average velocity in pipe, ΔV : Intensity of velocity fluctuation)

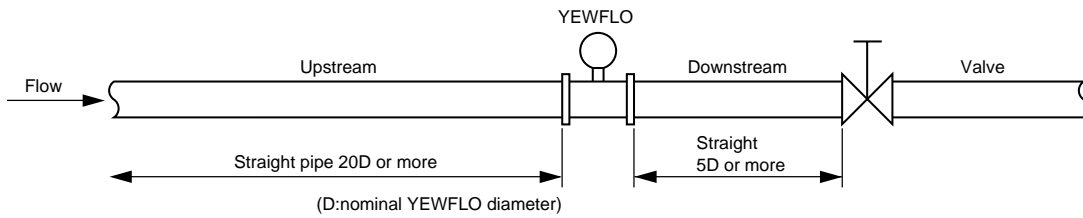

Figure 9.1.1

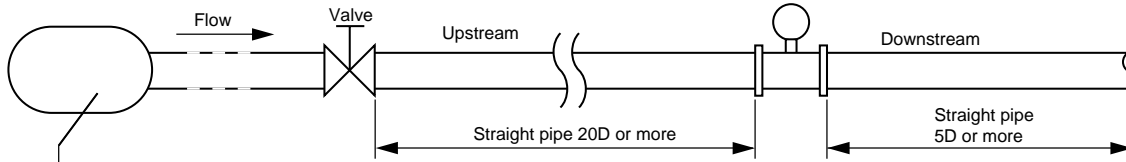

Figure 9.1.2

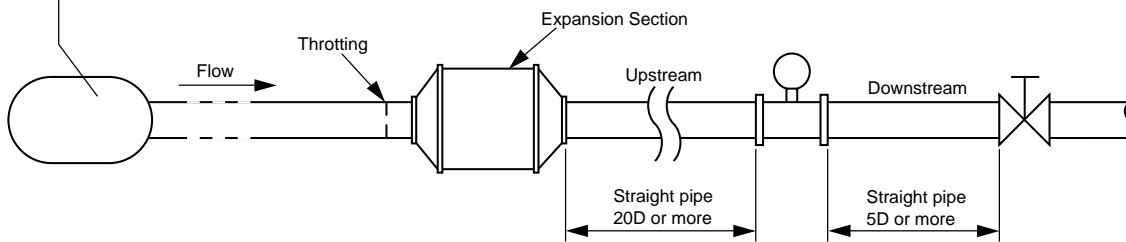

Figure 9.1.3

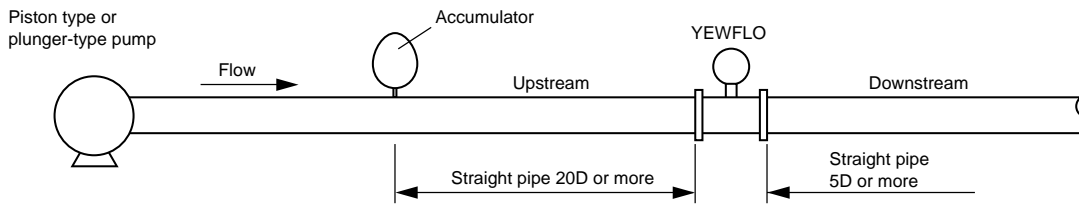

Figure 9.1.4

- Bent pipe and straight pipe length:
Ensure the upstream straight pipe length to be 10D or more, and the downstream straight pipe length be 5D or more for per bent pipe. (Refer to Figure 9.2.1)

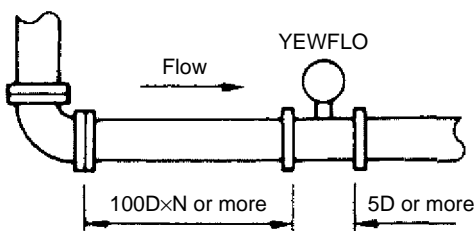

Figure 9.2.1

- Reducer or expander pipe:
Ensure the upstream straight pipe length be 5D or more, and the downstream straight Pipe length to be 5D or more for per reducer pipe.
Ensure the upstream straight pipe length be 10D or more, and the downstream straight pipe length be 5D or more for per expander pipe. (Refer to Figure 9.2.2)

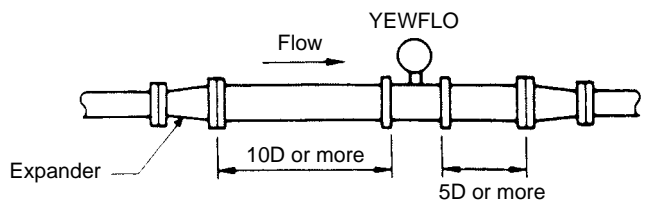
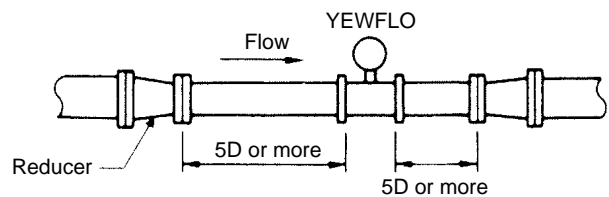

Figure 9.2.2

Figure 9.2

- Pressure tap outlet: install this tap between 2D and 7D on the downstream side of a flowmeter (Refer to Figure 9.3).
- Temperature tap outlet: install this on the downstream side 1D to 2D away from a pressure tap (Refer to Figure 9.3).

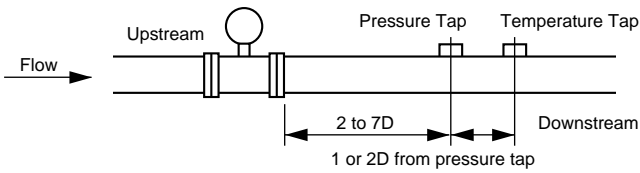
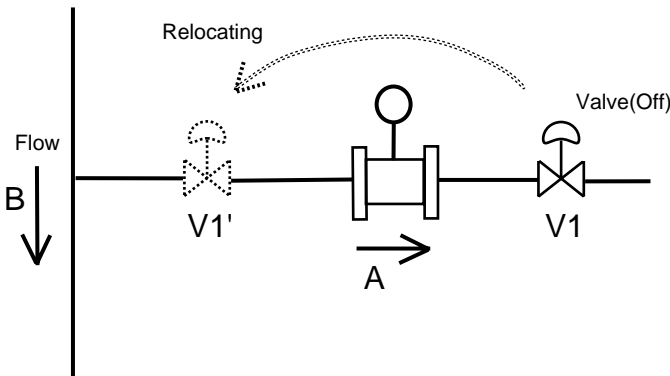

Figure 9.3

- When pulsating pressure cause by a T-type piping exist, install the valve on the upstream of the flowmeter.
Example: As shown in the figure below, when the valve V1 is turned off, the fluid flow through B, as to meter A the flow is zero. But due to the pulsating pressure is detected, the meter is zero point become fluctuating. To avoid this, change the valve V1 location to V1'.



- Flushing of pipe line (Cleaning)
Flush and clean scale, incrustation and sludge on the inside of pipe wall for newly installed pipe line and repaired pipe line before the operation. When flushing, the flow should flow through by-pass piping to avoid damaging the flowmeter. If there is no by-pass piping, install short pipe instead of the flowmeter.

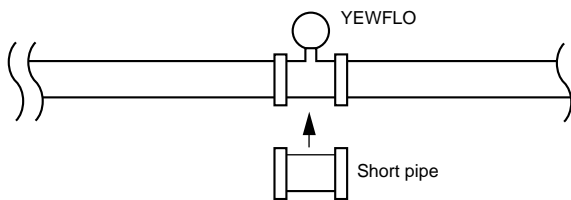

Figure 9.4 Flushing of pipe line

- If the fluid is crystallized and forms a hard mass, clean up flow tube and shedder bar.
- While measuring dirty fluid which contains sticky stuff, and those sticky stuff is bound between flow tube and shedder bar, clean them up.

- When the pipe carrying high-temperature fluids is heat-insulated, do not wrap heat-insulation materials around the installation bracket of the converter. (Refer to Figure 9.5)

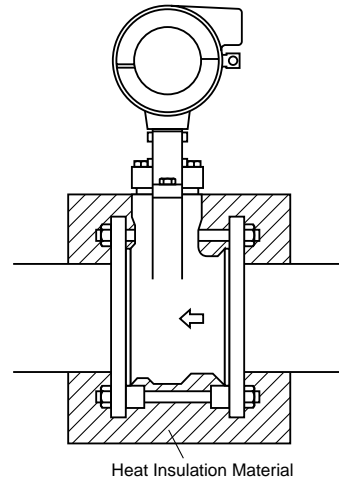

Figure 9.5 Heat Insulation Method.

Gasket:

Avoid mounting gaskets which protrude into the pipeline. This may cause inaccurate readings. Use gaskets with bolt holes, even if YEWFLO is the wafer type.

When using a spiral gasket (without bolt holes), confirm the size with the gasket-manufacturer, as standard items may not be used for certain flange ratings.

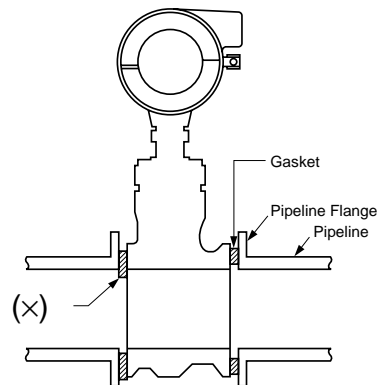

Figure 9.6

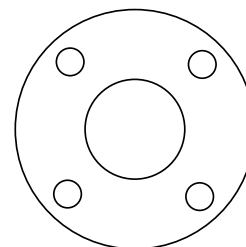
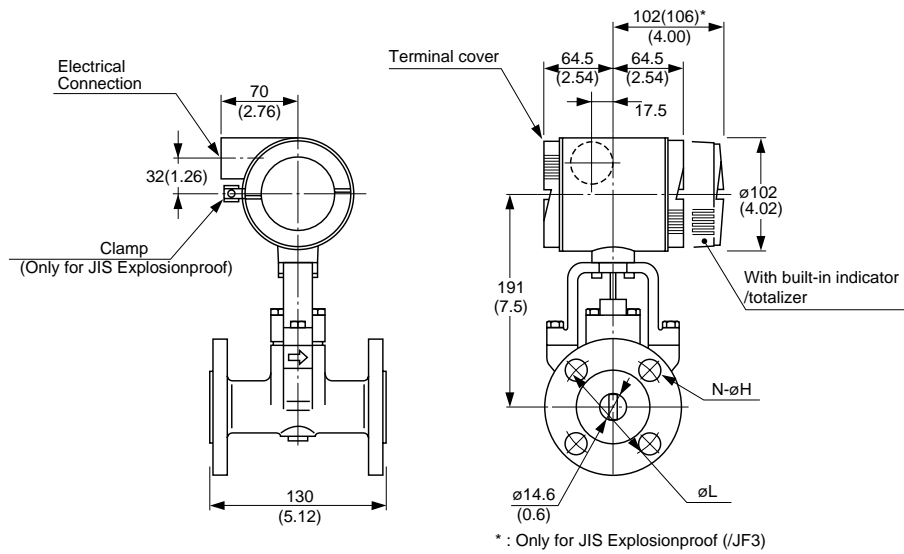

Figure 9.7 Gasket with Bolt Holes

EXTERNAL DIMENSIONS

- Integral Type
- Flange Type



Weight (kg)

Process connections	Weight
JIS10K	4.4(9.70)
JIS20K	4.5(9.92)
JIS40K	6.1(13.45)
ANSI,JPIClass150 JPIClass150	4.3(9.48)
ANSI,JPIClass300 JPIClass300	4.5(9.92)
ANSI,JPIClass600 JPIClass600	4.8(10.58)
DIN PN10/40	4.4(9.70)
DIN PN64/100	5.6(12.35)

(Note) For flowmeters with built-in indicator/totalizer, add 0.4 kg(0.91lb)

Center circle dia. (L)/Number of bolt holes (N)/Hole dia. (H)

Pressure rating	Nominal dia.		
	15mm(1/2 in)	øL	N øH
JIS	10K	70 (2.76)	4 15 (0.59)
	20K	70 (2.76)	4 15 (0.59)
	40K	80 (3.15)	4 19 (0.75)
ANSI JPI	Class150	60.5 (2.38)	4 15.7 (0.62)
	Class300	66.5 (2.62)	4 15.7 (0.62)
	Class600	66.5 (2.62)	4 15.7 (0.62)
DIN	PN10/40	65 (2.56)	4 14 (0.55)
	PN64/100	75 (2.95)	4 14 (0.55)

Fig24

- Integral Type
- Flange Type

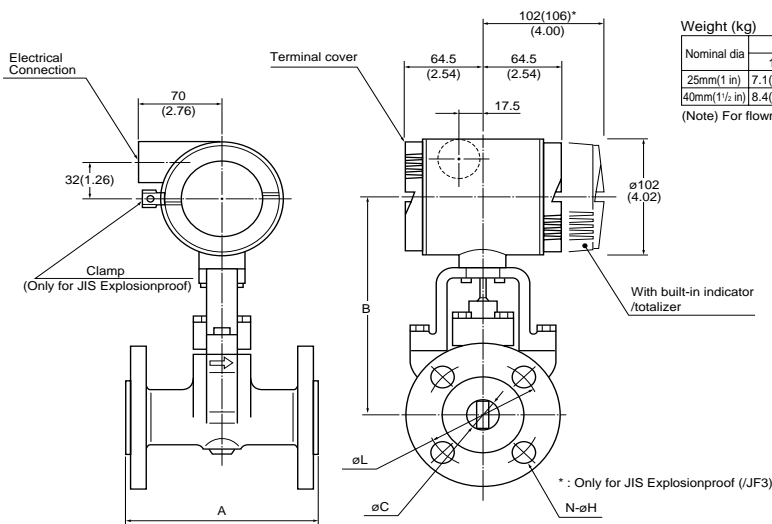

Weight (kg)

Nominal dia	JIS Flange			ANSI Flange, JPI Flange			DIN	
	10K	20K	40K	Class150	Class300	Class600	PN10/40	PN64/100
25mm(1 in)	7.1(15.65)	7.3(16.9)	8.8(19.40)	6.8(14.99)	7.4(16.31)	7.9(17.42)	7.1(19.84)	9.8(21.61)
40mm(1 1/2 in)	8.4(18.52)	8.8(18.96)	12.1(26.67)	8.3(18.30)	9.5(20.94)	11.5(25.35)	9.0(19.84)	12.9(28.44)

(Note) For flowmeters with built-in indicator/totalizer, add 0.4 kg(0.91lb)

Nominal dia	A	B	øC
25mm(1 in)	150(5.91)	193(7.60)	25.7(1.01)
40mm(1 1/2 in)	150(5.91)	200(7.87)	39.7(1.56)

Center circle dia. (L)/Number of bolt holes (N)/Hole dia. (H)

Pressure rating	Nominal dia		
	25mm(1 in)	40mm(1 1/2 in)	øL N øH
JIS	10K	90 (3.54)	4 19 (0.75) 105 (4.13) 19 (0.75)
	20K	90 (3.54)	4 19 (0.75) 105 (4.13) 19 (0.75)
	40K	95 (3.74)	4 19 (0.75) 120 (4.72) 23 (0.91)
ANSI JPI	Class150	79.2 (3.12)	4 15.7 (0.62) 98.6 (3.88) 15.7 (0.62)
	Class300	88.9 (3.50)	4 19 (0.75) 114.3 (4.50) 22.4 (0.88)
	Class600	89 (3.50)	4 19 (0.75) 114.3 (4.50) 22.4 (0.88)
DIN	PN10/40	85 (3.35)	4 14 (0.55) 100 (3.94) 18 (0.71)
	PN64/100	100 (3.94)	4 18 (0.71) 125 (4.92) 22 (0.87)

Fig25

■ Integral Type

● Flange Type

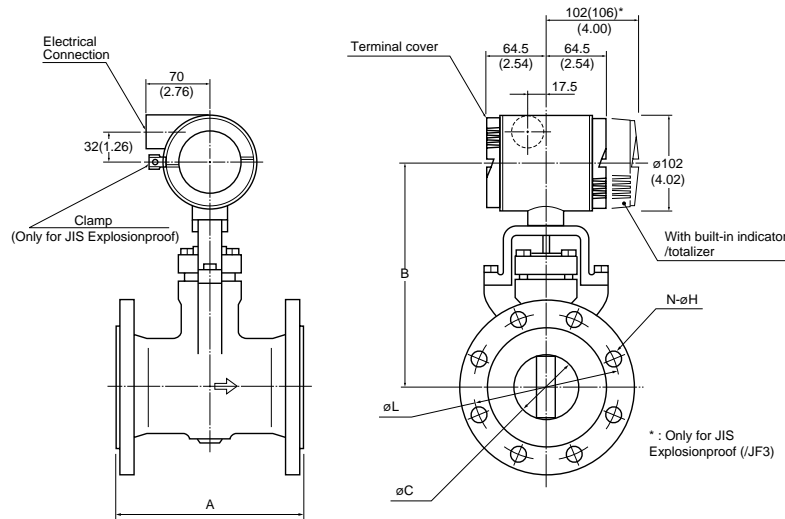

* : Only for JIS Explosionproof (JF3)

Nominal dia.	A	B	øC
50mm(2 in)	170(6.69)	222(8.74)	51.1(2.01)
80mm(3 in)	200(7.78)	239(9.24)	71.0(2.80)
100mm(4 in)	220(9.66)*	254(10.00)	93.8(3.69)

*240 mm for ANSI Class 600 and JPI Class 600

Weight (kg)

Nominal dia.	JIS Flange			ANSI Flange, JPI Flange			DIN			
	10K	20K	40K	Class150	Class300	Class600	PN10/16	PN25/40	PN64	PN100
50mm(2 in)	11.3 (24.91)	11.8 (26.01)	14.5 (31.97)	11.3 (26.23)	13.4 (29.54)	15.0 (33.07)	11.5 (25.35)	11.5 (25.35)	14.5 (31.97)	15.4 (33.95)
80mm(3 in)	17.6 (38.80)	20.2 (44.53)	25.6 (56.44)	20.2 (44.53)	24.0 (52.90)	25.6 (56.44)	19.6 (43.21)	20.2 (44.53)	24.3 (53.37)	27.2 (59.97)
100mm(4 in)	23.0 (50.71)	27.0 (59.52)	38.3 (84.44)	27.6 (60.85)	36.1 (79.57)	51.0 (112.43)	23.4 (51.59)	27.6 (60.35)	33.2 (73.19)	39.9 (87.95)

(Note) For flowmeters with built-in indicator/totalizer, add 0.4 kg(0.91lb)

Center circle dia. (L)/Number of bolt holes (N)/Hole dia. (H)

Pressure rating	Nominal dia.	50mm(2 in)			80mm(3 in)			100mm(4 in)		
		øL	N	øH	øL	N	øH	øL	N	øH
JIS	10K	120 (4.72)	4	19 (0.75)	150 (5.91)	8	19 (0.75)	175 (6.89)	8	19 (0.75)
	20K	120 (4.72)	8	19 (0.75)	160 (6.30)	8	23 (0.91)	185 (7.28)	8	23 (0.91)
	40K	130 (5.12)	8	19 (0.75)	170 (6.69)	8	23 (0.91)	205 (8.07)	8	25 (0.98)
ANSI JPI	Class150	120 (4.75)	4	19 (0.75)	152.4 (6.00)	4	19 (0.75)	190.5 (7.50)	8	19 (0.75)
	Class300	127 (5.00)	8	19 (0.75)	168.2 (6.62)	8	22.4 (0.88)	200.2 (7.88)	8	22.4 (0.88)
	Class600	127 (5.00)	8	19 (0.75)	168 (6.61)	8	22.4 (0.88)	216 (8.50)	8	25.4 (1.00)
DIN	PN10/16	125 (4.29)	4	18 (0.71)	160 (6.30)	8	18 (0.71)	180 (7.05)	8	18 (0.71)
	PN25/40	125 (4.92)	4	18 (0.71)	160 (6.30)	8	18 (0.71)	190 (7.48)	8	22 (0.87)
	PN64	135 (5.31)	4	18 (0.87)	170 (6.69)	8	22 (0.87)	200 (7.87)	8	26 (1.02)
	PN100	145 (5.71)	4	26 (1.02)	180 (7.09)	8	26 (1.02)	210 (8.27)	8	30 (1.18)

Fig26

■ Integral Type

● Flange Type

Weight (kg)

Nominal dia.	JIS Flange			ANSI Flange, JPI Flange			DIN			
	10K	20K	40K	Class150	Class300	Class600	PN10/16	PN25/40	PN64	PN100
150mm(6 in)	33.6 (74.07)	43.6 (96.12)	76.6 (168.87)	38.6 (80.69)	54.6 (120.37)	84.6 (186.51)	33.6 (74.07)	43.6 (96.12)	53.3 (118.53)	76.8 (168.87)
200mm(8 in)	45.8 (100.53)	52.6 (115.96)	100.0 (220.46)	55.6 (122.57)	80.6 (177.69)	140.7 (310.19)	46.5 (102.52)	46.5 (102.52)	53.8 (118.61)	86.1 (189.68)

(Note) For flowmeters with built-in indicator/totalizer, add 0.4 kg(0.9lb)

Nominal dia.	A	B	øC
150mm(6 in)	270(10.63) ^{*1}	273(10.75)	138.8(5.46)
200mm(8 in)	310(12.20) ^{*2}	305(12.01)	185.6(7.31)

*1: A = 310 mm for ANSI Class 600 and JPI Class 600
*2: A = 375 mm for ANSI Class 600 and JPI Class 600

Center circle dia. (L)/Number of bolt holes (N)/Hole dia. (H)

Pressure rating	Nominal dia.	150mm(6 in)			200mm(8 in)		
		øL	N	øH	øL	N	øH
JIS	10K	240 (9.45)	8	23 (0.91)	290 (11.42)	12	23 (0.91)
	20K	260 (10.24)	12	25 (0.91)	305 (12.01)	12	25 (0.98)
	40K	295 (11.61)	12	33 (1.30)	330 (12.99)	12	33 (1.30)
ANSI JPI	Class150	241.3 (9.50)	8	22.4 (0.88)	298.5 (11.75)	8	22.4 (0.88)
	Class300	269.7 (10.62)	12	22.4 (0.88)	330.2 (13.00)	12	25.4 (1.00)
	Class600	292 (11.50)	12	28.4 (1.12)	349.3 (13.75)	12	31.8 (1.25)
DIN	PN10/60	240 (9.45)	8	22 (0.87)	295 (11.61)	8	22 (0.87)
	PN25/40	250 (9.84)	8	26 (1.02)	295 (11.61)	12	22 (0.87)
	PN64	280 (11.02)	8	33 (1.30)	310 (12.20)	12	25 (0.98)
	PN25	290 (11.02)	8	33 (1.30)	320 (12.60)	12	26 (1.02)
	PN100	290 (11.42)	12	33 (1.30)	320 (12.60)	12	30 (1.18)

* : Only for JIS Explosionproof (JF3)

Fig27

■ Integral Converter
● Flange Type

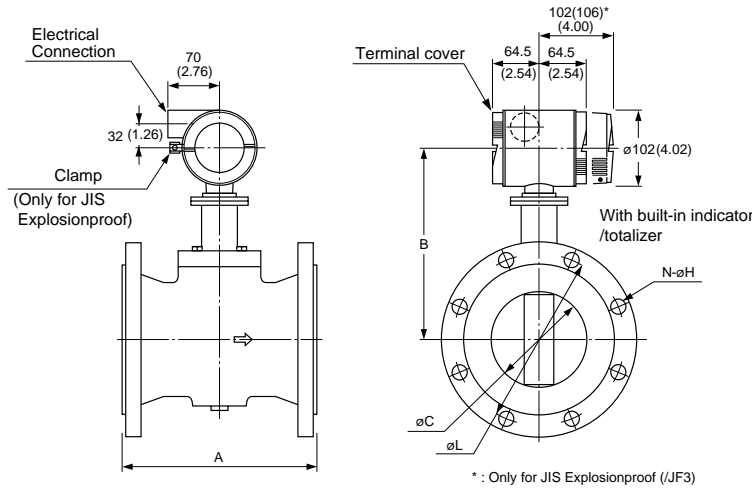

Normal Size	A	B	øC
250mm(10in)	370 (14.57)	341 (13.94)	230.8 (9.09)
300mm(12in)	400 (15.75)	371 (14.61)	276.2 (10.87)

Weight : kg(lb)

Normal Size	JISFlange		ANSIFlange, JPIFlange	
	10K	20K	class150	class300
250mm(10 in)	78 (171.96)	100 (220.46)	90 (198.41)	125 (275.58)
300mm(12 in)	100 (220.46)	128 (282.19)	140 (308.64)	178 (392.42)

Note : with integral Totalizer Option : Add 0.4kg

Dia. of Bolt Circle (L)/Number of Bolts(N)/Dia. of Bolts(H)

Pressure Rating	Normal Size	250mm(10 in)			300mm(12 in)		
		øL	N	øH	øL	N	øH
JIS	10K	355 (13.98)	12	25 (1)	400 (15.75)	16	25 (1)
	20K	380 (13.98)	12	27 (1.06)	430 (16.93)	16	27 (1.06)
ANSI JPI	Class150	362 (13.98)	12	25.4 (1)	432 (17)	12	25.4 (1)
	Class300	387 (13.98)	16	28.6 (1.03)	451 (17.75)	16	31.8 (1.25)

Fig28

■ Integral Type
● Wafer Type

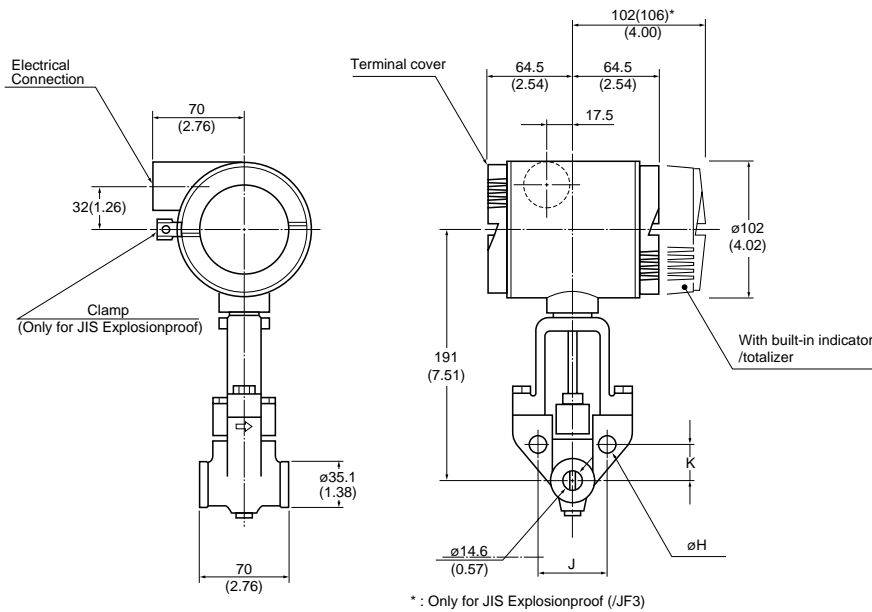

Weight: 3kg(6.6lb)
(Note) For flowmeters with built-in indicator/totalizer, add 0.4kg(0.9lb)

Hole diameter (H)

Pressure rating	Nominal dia.			
	K	J	øH	
JIS	10K	24.7 (0.97)	49.5 (1.95)	13 (0.51)
	20K	28.3 (1.11)	56.6 (2.23)	17 (0.67)
	40K	21.4 (0.84)	42.7 (1.68)	14 (0.55)
ANSI JPI	Class 150	23.5 (0.93)	47.1 (1.85)	14 (0.55)
	Class 300	23 (0.91)	46.0 (1.81)	13 (0.51)
DIN	PN10/40	23 (0.91)	46.0 (1.81)	13 (0.51)

Fig29

- Integral Type
- Wafer Type

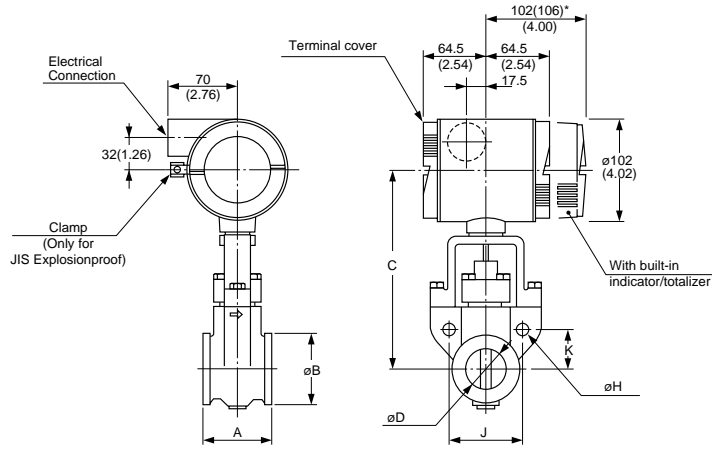

* : Only for JIS Explosionproof (JF3)

Nominal dia.	A	øB	C	øD	Weight
25mm(1 in)	70(2.76)	50.8(2.00)	193(7.60)	25.7(1.01)	3.9kg(8.61 lb)
40mm(1½ in)	70(2.76)	73.0(2.87)	200(7.87)	39.7(1.56)	4.5kg(9.93 lb)
50mm(2 in)	75(2.95)	92.0(3.62)	222(8.74)	51.1(2.01)	6.2kg(13.69 lb)

(Note) For flowmeters with built-in indicator/totalizer, add 0.4 kg(0.91lb)

Hole diameter (H)

Nominal dia.	25mm(1 in)			40mm(1½ in)			50mm(2 in)			
	K	J	øH	K	J	øH	K	J	øH	
JIS	10K	31.8 (1.25)	63.6 (2.50)	17 (0.67)	37.1 (1.46)	74.2 (2.92)	17 (0.67)	-	-	-
	20K	-	-	-	-	-	55.4 (2.18)	45.9 (1.81)	17 (0.67)	
	40K	33.6 (1.32)	67.2 (2.65)	17 (0.67)	42.4 (1.67)	84.9 (3.34)	21 (0.83)	60.1 (2.37)	49.8 (1.96)	17 (0.67)
ANSI JPI	Class150	28 (1.10)	56 (2.20)	14 (0.55)	34.8 (1.37)	69.7 (2.74)	14 (0.55)	-	-	-
	Class300	31.4 (1.24)	62.9 (2.48)	17 (0.67)	40.4 (1.59)	80.8 (3.18)	20 (0.79)	58.7 (2.31)	48.6 (1.91)	17 (0.67)
	Class600	-	-	-	-	-	-	-	-	-
DIN	PN10/40	30.1 (1.19)	60.1 (2.37)	13 (0.51)	38.9 (1.53)	77.8 (3.06)	17 (0.67)	-	-	-

* - : Hole is not provided.
Fig30

- Integral Type
- Wafer Type

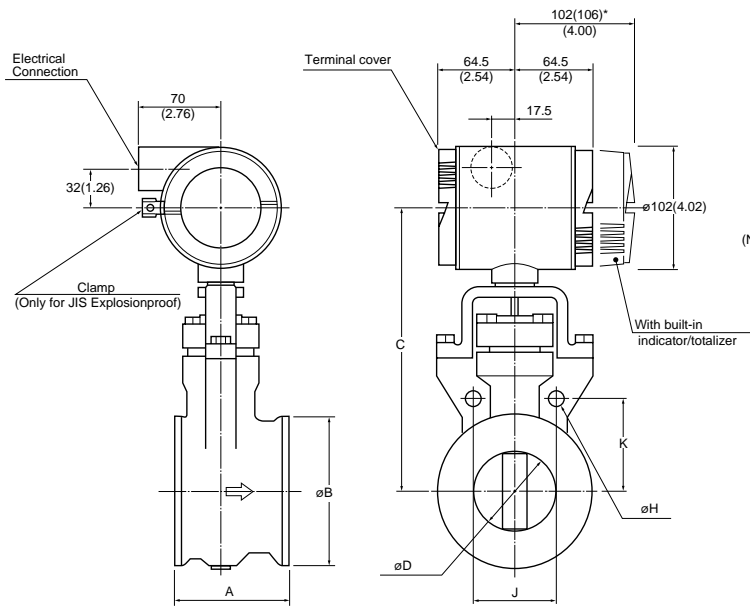

* : Only for JIS Explosionproof (JF3)

Nominal dia.	A	øB	C	øD	Weight
80mm(3 in)	100(3.94)	127.0(5.00)	239(9.41)	71.0(2.80)	9.6kg(21.16 lb)
100mm(4 in)	120(4.72)	157.2(6.19)	254(10.00)	93.8(3.69)	13.0kg(28.66 lb)

(Note) For flowmeters with built-in indicator/totalizer, add 0.4 kg(0.91lb)

Hole diameter (H)

Nominal dia.	80mm(3 in)			100mm(4 in)			
	K	J	øH	K	J	øH	
JIS	10K	69.3 (2.73)	57.4 (2.26)	17 (0.67)	80.8 (3.18)	67.0 (2.64)	17 (0.67)
	20K	73.9 (2.91)	61.2 (2.41)	21 (0.83)	85.5 (3.37)	70.8 (2.79)	21 (0.83)
	40K	78.5 (3.09)	65.1 (2.56)	21 (0.83)	94.7 (3.73)	78.5 (3.09)	23 (0.91)
ANSI JPI	Class150	-	-	-	88.0 (3.46)	72.9 (2.87)	17 (0.67)
	Class300	77.7 (3.06)	64.4 (2.54)	20 (0.79)	92.5 (3.64)	76.6 (3.02)	20 (0.79)
	Class600	-	-	-	99.7 (3.93)	82.6 (3.25)	23 (0.91)
DIN	PN10/16	73.9 (2.91)	61.2 (2.41)	17 (0.67)	83.1 (3.27)	68.9 (3.71)	17 (0.67)
	PN25/40	73.9 (2.91)	61.2 (2.41)	17 (0.67)	87.8 (3.47)	72.7 (3.71)	21 (0.67)

* - : Hole is not provided.

Fig31

■ Vortex Flow Detector
● Flange Type

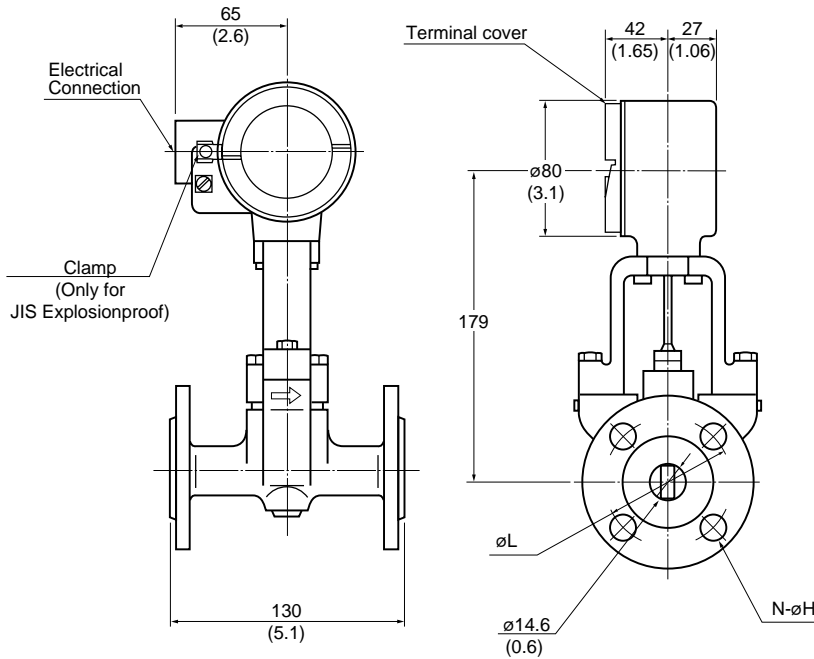

Weight (kg)

Process connection	Weight
JIS10K	3.7(8.2)
JIS20K	3.8(8.4)
JIS40K	5.4(11.9)
ANSIClass150 JPIClass150	3.6(7.9)
ANSIClass300 JPIClass300	3.8(8.4)
ANSIClass600 JPIClass600	4.1(9.1)
DIN PN10/40	3.7(8.2)
DIN PN64/100	4.9(10.8)

Center circle dia.
(L)/Number of bolt holes (N)/Hole dia. (H)

Pressure rating	Nominal dia	15mm(1/2 in)		
		øL	N	øH
JIS	10K	70 (2.76)	4	15 (0.59)
	20K	70 (2.76)	4	15 (0.59)
	40K	80 (3.15)	4	19 (0.75)
ANSI JPI	Class150	60.5 (2.38)	4	15.7 (0.62)
	Class300	66.5 (2.62)	4	15.7 (0.62)
	Class600	66.5 (2.62)	4	15.7 (0.62)
DIN	PN10/40	65 (2.56)	4	14 (0.55)
	PN64/100	75 (2.95)	4	14 (0.55)

Fig32

■ Vortex Flow Detector
● Flange Type

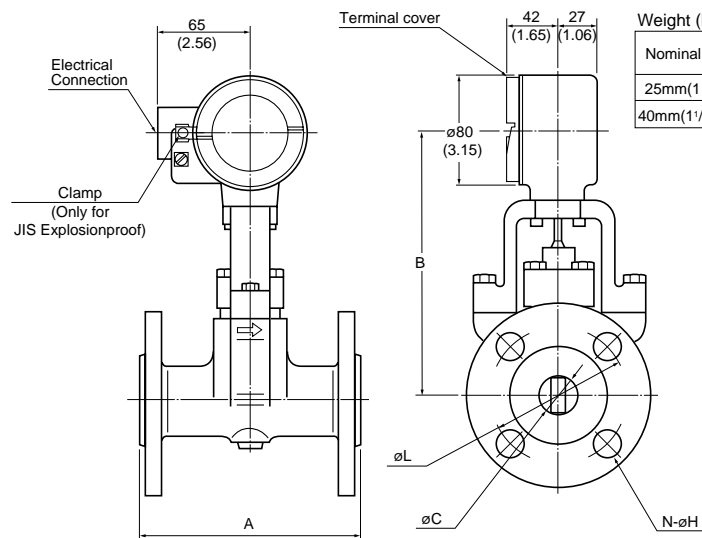

Weight (kg)

Nominal dia.	JIS Flange			ANSI Flange, JPI Flange			DIN	
	10K	20K	40K	Class150	Class300	Class600	PN10/40	PN64/100
25mm(1 in)	6.4 (14.10)	6.8 (14.55)	8.1 (17.85)	6.1 (13.45)	6.7 (14.77)	7.2 (15.87)	6.4 (14.10)	9.1 (20.06)
40mm(1 1/2 in)	7.7 (16.97)	7.9 (17.41)	11.4 (25.13)	7.6 (16.75)	8.8 (19.40)	10.8 (23.81)	8.3 (18.30)	12.2 (26.90)

Nominal dia.	A	B	øC
25mm(1 in)	150(5.91)	181(7.13)	25.7(1.01)
40mm(1 1/2 in)	150(5.91)	188(7.40)	39.7(1.56)

Center circle dia. (L)/Number of bolt holes (N)/Hole dia. (H)

Pressure rating	Nominal dia	25mm(1 in)			40mm(1 1/2 in)		
		øL	N	øH	øL	N	øH
JIS	10K	90 (3.54)	4	19 (0.75)	105 (4.13)	4	19 (0.75)
	20K	90 (3.54)	4	19 (0.75)	105 (4.13)	4	19 (0.75)
	40K	95 (3.74)	4	19 (0.75)	120 (4.72)	4	23 (0.91)
ANSI JPI	Class150	79.2 (3.12)	4	15.7 (0.62)	98.6 (3.88)	4	15.7 (0.62)
	Class300	88.9 (3.50)	4	19 (0.75)	114.3 (4.50)	4	22.4 (0.88)
	Class600	89 (3.50)	4	19 (0.75)	114.3 (4.50)	4	22.4 (0.88)
DIN	PN10/40	85 (3.35)	4	14 (0.55)	110 (4.33)	4	18 (0.71)
	PN64/100	100 (3.94)	4	18 (0.71)	125 (4.92)	4	22 (0.87)

Fig33

■ Vortex Flow Detector
● Flange Type

Weight (kg)

Nominal dia.	JIS Flange			ANSI Flange, JPI Flange			DIN			
	10K	20K	40K	Class150	Class300	Class600	PN10/16	PN25/40	PN64	PN100
50mm(2 in)	10.8 (23.37)	11.1 (24.47)	13.8 (30.24)	11.2 (24.69)	12.7 (28.00)	13.1 (28.88)	10.8 (23.81)	10.3 (22.81)	13.8 (30.42)	14.7 (32.41)
80mm(3 in)	16.9 (37.26)	19.5 (42.99)	24.9 (54.98)	19.4 (42.77)	23.5 (51.36)	24.9 (54.89)	18.9 (41.67)	19.5 (42.99)	23.6 (52.03)	26.5 (58.42)
100mm(4 in)	22.3 (49.16)	26.3 (57.98)	37.5 (83.18)	26.9 (59.30)	35.4 (78.04)	50.3 (110.89)	27.7 (60.04)	26.9 (59.30)	32.5 (71.65)	38.2 (84.22)

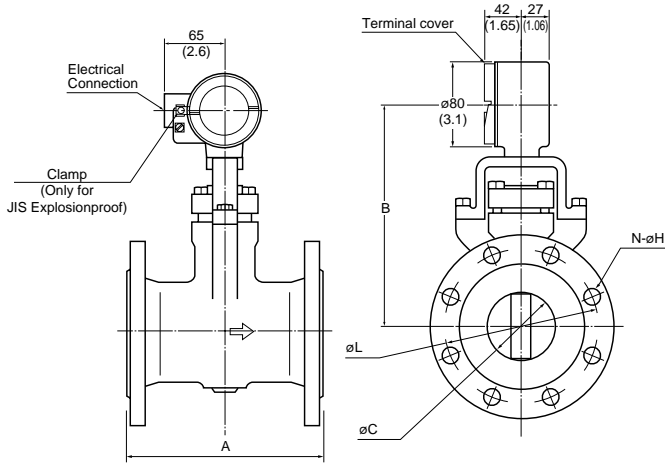

Nominal dia.	A	B	øC
50mm(2 in)	170(6.69)	210(8.27)	51.1(2.01)
80mm(3 in)	200(7.87)	227(8.94)	71.0(2.80)
100mm(4 in)	220(8.66)	242(9.53)	93.8(3.69)

(Note) Use the YF011 type signal cable.

Center circle dia. (L)/Number of bolt holes (N)/Hole dia. (H)

Nominal dia.	50mm(2 in)			80mm(3 in)			100mm(4 in)		
	øL	N	øH	øL	N	øH	øL	N	øH
JIS	10K	4	19 (0.75)	150 (5.91)	8	19 (0.75)	175 (6.89)	8	19 (0.75)
	20K	8	19 (0.75)	160 (6.30)	8	23 (0.91)	185 (7.28)	8	23 (0.91)
	40K	8	19 (0.75)	170 (6.69)	8	23 (0.91)	205 (8.07)	8	25 (0.98)
ANSI JPI	Class150	4	19 (0.75)	152.4 (6.00)	4	19 (0.75)	190.5 (7.50)	8	19 (0.75)
	Class300	8	19 (0.75)	168.2 (6.62)	8	22.4 (0.88)	200.2 (7.88)	8	22.4 (0.88)
	Class600	8	19 (0.75)	168 (6.61)	8	22.4 (0.88)	216 (8.50)	8	25.4 (1.00)
DIN	PN10/16	4	18 (0.71)	160 (6.30)	8	18 (0.71)	180 (7.09)	8	18 (0.71)
	PN25/40	4	18 (0.71)	160 (6.30)	8	18 (0.71)	190 (7.48)	8	22 (0.87)
	PN64	4	22 (0.87)	170 (6.69)	8	22 (0.87)	200 (7.87)	8	26 (1.02)
	PN100	4	26 (1.02)	180 (7.09)	8	26 (1.02)	210 (8.27)	8	30 (1.18)

Fig34

■ Vortex Flow Detector
● Flange Type

Weight (kg)

Nominal dia.	JIS Flange			ANSI Flange, JPI Flange			DIN			
	10K	20K	40K	Class150	Class300	Class600	PN10/16 PN10	PN25/40 PN16	PN64 PN25	PN100 PN40
150mm(6 in)	33 (72.75)	43 (92.75)	76 (167.55)	36 (79.37)	54 (119.05)	84 (185.19)	32.9 (72.53)	42.4 (93.48)	57.6 (126.99)	75.9 (167.33)
200mm(8 in)	45 (99.21)	52 (114.21)	76 (167.55)	55 (121.25)	80 (176.37)	140 (308.64)	45.8 (100.97)	45.8 (100.97)	53.1 (117.07)	55.4 (122.14)

Nominal dia.	A	B	øC
150mm(6 in)	270(10.63)*	261(10.28)	138.8(5.46)
200mm(8 in)	310(12.20)**	293(11.54)	185.6(7.31)

*1: A = 310 mm for ANSI Class 600 and JPI Class 600
*2: A = 375 mm for ANSI Class 600 and JPI Class 600

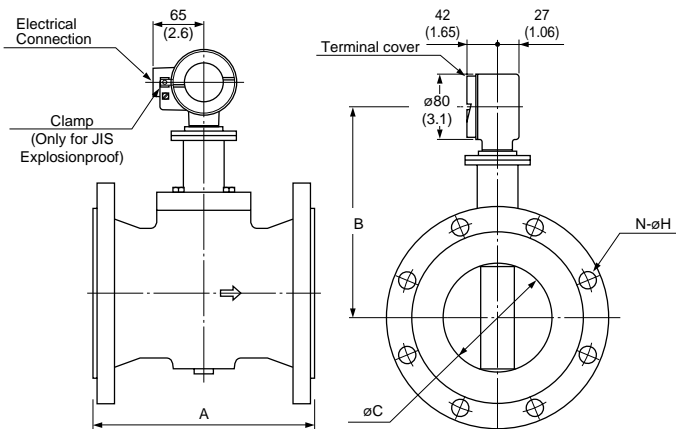

Center circle dia. (L)/Number of bolt holes (N)/Hole dia. (H)

Nominal dia.	150mm(6 in)			200mm(8 in)		
	øL	N	øH	øL	N	øH
JIS	10K	8	23 (0.91)	290 (11.42)	12	23 (0.91)
	20K	12	25 (0.91)	305 (12.01)	12	25 (0.98)
	40K	12	33 (1.30)	349.3 (13.75)	12	31.8 (1.25)
ANSI JPI	Class150	8	22.4 (0.88)	298.5 (11.75)	8	22.4 (0.88)
	Class300	12	22.4 (0.88)	330.2 (13.00)	12	25.4 (1.00)
	Class600	12	28.4 (1.12)	349.3 (13.75)	12	31.8 (1.25)
DIN	PN10/16 PN10	8	22 (0.87)	295 (11.61)	8	22 (0.87)
	PN25/40 PN16	8	26 (1.02)	295 (11.61)	12	22 (0.87)
	PN64 PN25	8	33 (1.30)	310 (12.20)	12	26 (1.02)
	PN100 PN40	12	33 (1.30)	320 (12.60)	12	30 (1.18)

Fig35

■ Vortex Flow Detector

● Flange Type

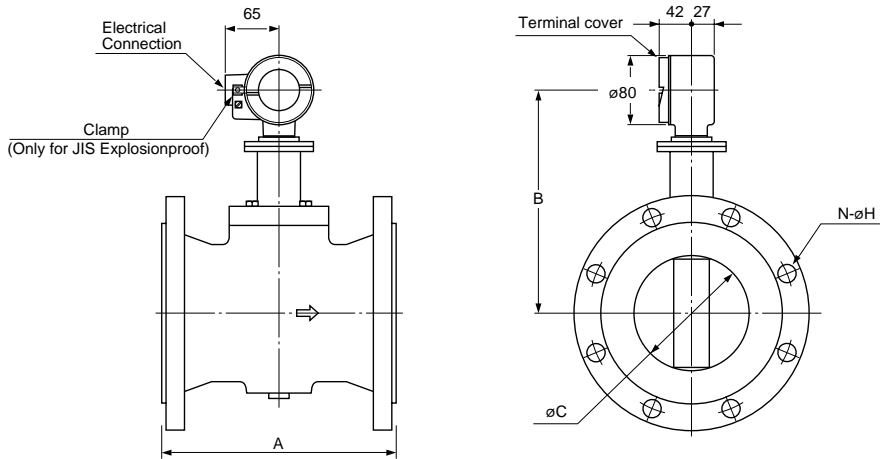

Clamp
(Only for JIS Explosionproof)

Normal Size	A	B	C
250mm(10in)	370(14.57)	329(12.95)	230.8(9.09)
300mm(12in)	400(15.75)	359(14.13)	276.2(10.87)

Weight(kg)

Normal Size	JIS Flange		ANSI Flange, JPI Flange	
	10K	20K	Class150	Class300
250mm(10in)	77(154.35)	99(198.46)	89(178.41)	124(248.57)
300mm(12in)	99(198.46)	127(254.58)	139(278.64)	177(354.81)

Dia. of Bolt Circle(L)/Number of Bolts(N)/Dia. of Bolts(H)

Pressure Rating	Normal Size	250mm(10 in)			300mm(12 in)		
		øL	N	øH	øL	N	øH
JIS	10K	355 (13.98)	12	25.0 (1)	400 (15.75)	16	25.0 (1)
	20K	380 (14.96)	12	27.0 (1.06)	430 (16.93)	16	27.0 (1.06)
ANSI JPI	Class150	362 (14.25)	12	25.4 (1)	432 (17)	12	25.4 (1)
	Class300	387 (15.25)	16	28.6 (1.13)	451 (17.75)	16	31.8 (1.25)

Fig36

■ Vortex Flow Detector

● Wafer Type

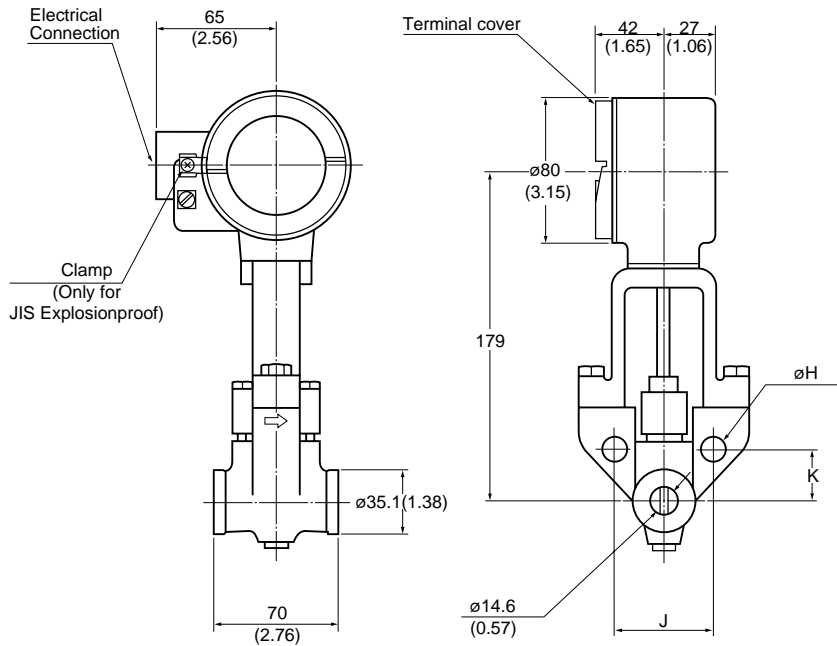

Weight: 2.3kg

Hole diameter (H)

Pressure rating	Nominal dia 15mm(1/2 in)			
	K	J	øH	
JIS	10K	24.7 (0.97)	49.5 (1.95)	13 (0.51)
	20K	28.3 (1.11)	56.6 (2.33)	17 (0.67)
	40K	21.4 (0.84)	42.7 (1.68)	14 (0.55)
ANSI JPI	Class150	23.5 (0.93)	47.1 (1.85)	14 (0.55)
	Class300	23.5 (0.93)	47.1 (1.85)	14 (0.55)
	Class600	23.5 (0.93)	47.1 (1.85)	14 (0.55)
DIN	PN10/40	23 (0.91)	46 (1.81)	13 (0.51)

Fig37

■ Vortex Flow Detector

● Wafer Type

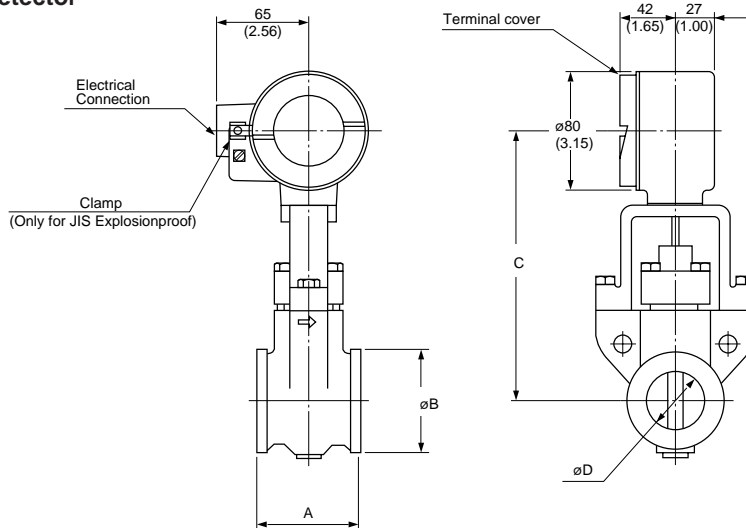

Nominal dia.	A	øB	C	øD	Weight
25mm(1 in)	70(2.76)	50.8(2.00)	181(7.13)	25.7(1.01)	3.2kg(7.05 lb)
40mm(1½ in)	70(2.76)	73.0(2.87)	188(7.40)	39.7(1.56)	3.8kg(8.38 lb)
50mm(2 in)	75(2.95)	92.0(3.62)	210(8.27)	51.1(2.01)	5.5kg(12.13 lb)

Hole diameter (H)

Pressure rating	25mm(1 in)			40mm(1½ in)			50mm(2 in)			
	K	J	øH	K	J	øH	K	J	øH	
JIS	10K	31.8 (1.25)	63.6 (2.50)	17 (0.67)	37.1 (1.46)	74.2 (2.92)	17 (0.67)	* -	* -	* -
	20K						55.4 (2.18)	45.9 (1.81)	17 (0.67)	
	40K	33.6 (1.32)	67.2 (2.65)	17 (0.67)	42.4 (1.67)	84.9 (3.34)	21 (0.83)	60.1 (2.37)	49.8 (1.96)	17 (0.67)
ANSI JPI	Class150	28 (1.10)	56 (2.20)	14 (0.55)	34.8 (1.37)	69.7 (2.74)	14 (0.55)	* -	* -	* -
	Class300	31.4 (1.24)	62.9 (2.48)	17 (0.67)	40.4 (1.59)	80.8 (3.18)	20 (0.79)	58.7 (2.31)	48.6 (1.91)	17 (0.67)
	Class600									
DIN	PN10/40	30.1 (1.19)	60.1 (2.37)	13 (0.51)	38.9 (1.53)	77.8 (3.06)	17 (0.67)	* -	* -	* -

Fig38

*-: Hole is not provided

■ Vortex Flow Detector

● Wafer Type

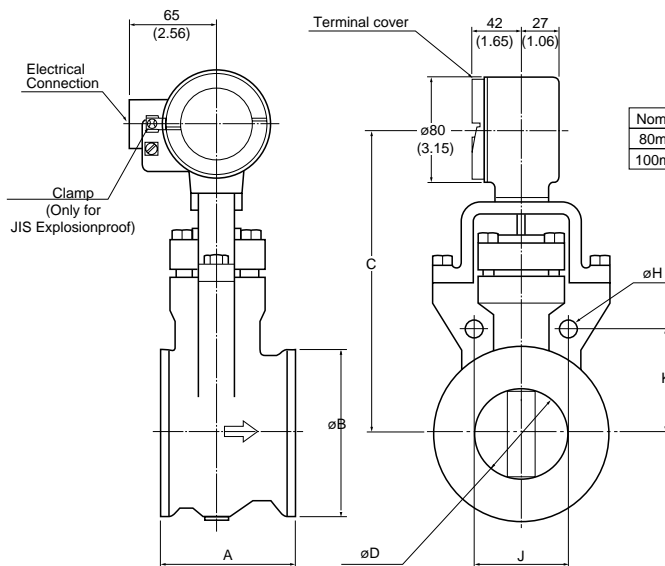

Nominal dia.	A	øB	C	øD	Weight
80mm(3 in)	100(3.94)	127.0(5.00)	227(8.94)	71.0(2.79)	8.9kg(19.62 lb)
100mm(4 in)	120(4.72)	157.2(6.19)	242(9.53)	93.8(3.69)	12.3kg(27.12 lb)

Hole diameter (H)

Pressure rating	80mm(3 in)			100mm(4 in)			
	K	J	øH	K	J	øH	
JIS	10K	69.3 (2.73)	57.4 (2.26)	17 (0.67)	80.8 (3.18)	67.0 (2.64)	17 (0.67)
	20K	73.9 (2.91)	61.2 (2.41)	21 (0.83)	85.5 (3.37)	70.8 (2.79)	21 (0.83)
	40K	78.5 (3.09)	65.1 (2.56)	21 (0.83)	94.7 (3.73)	78.5 (3.09)	23 (0.91)
ANSI JPI	Class150	* -	* -	* -	88.0 (3.46)	72.9 (2.87)	17 (0.67)
	Class300	77.7 (3.06)	64.4 (2.54)	20 (0.67)	92.5 (3.64)	76.6 (3.02)	20 (0.79)
	Class600				99.7 (3.93)	82.6 (3.25)	23 (0.91)
DIN	PN10/16	73.9 (2.91)	61.2 (2.41)	17 (0.67)	83.1 (3.27)	68.9 (2.71)	17 (0.67)
	PN25/40	73.9 (2.91)	61.2 (2.41)	17 (0.67)	87.8 (3.46)	72.7 (2.86)	21 (0.83)

Fig39

*-: Hole is not provided

■ Vortex Flow Detector (/LPT)

● Flange Type

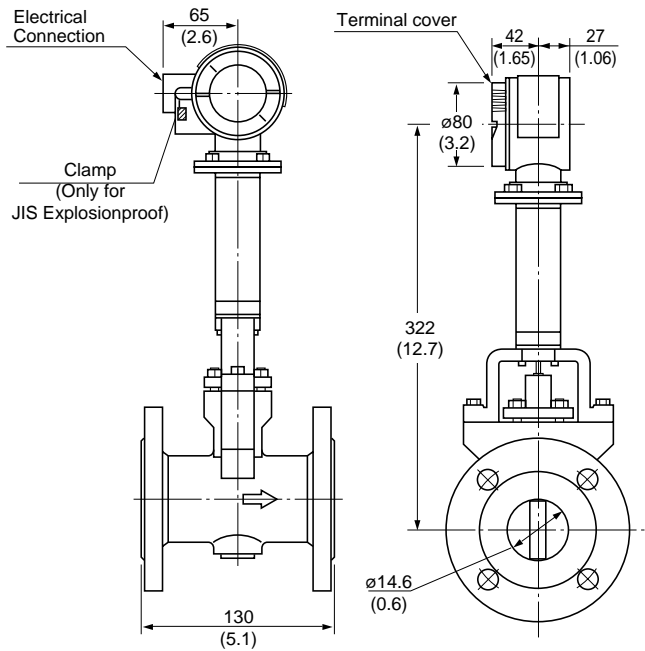

Weight (kg)

Process connection	Weight
JIS10K	4.1(9.1)
JIS20K	4.2(9.3)
JIS40K	5.8(12.8)
ANSI, JPI Class150 JPI Class150	4.0(8.8)
ANSI, JPI Class300 JPI Class300	4.2(9.3)
ANSI, JPI Class600 JPI Class600	4.5(9.9)
DIN PN10/40	4.1(9.1)
DIN PN64/100	5.3(11.7)

Hole diameter (H)

Pressure rating		Nominal dia		
		15mm(1/2 in)		
		øL	N	øH
JIS	10K	70 (2.76)	4	15 (0.59)
	20K	70 (2.76)	4	15 (0.59)
	40K	80 (3.15)	4	19 (0.75)
ANSI JPI	Class150	60.5 (2.38)	4	15.7 (0.62)
	Class300	66.5 (2.62)	4	15.7 (0.62)
	Class600	66.5 (2.62)	4	15.7 (0.62)
DIN	PN10/40	65 (2.55)	4	14 (0.55)
	PN64/100	75 (2.95)	4	14 (0.55)

Fig40

■ Vortex Flow Detector (/LPT)

● Wafer Type

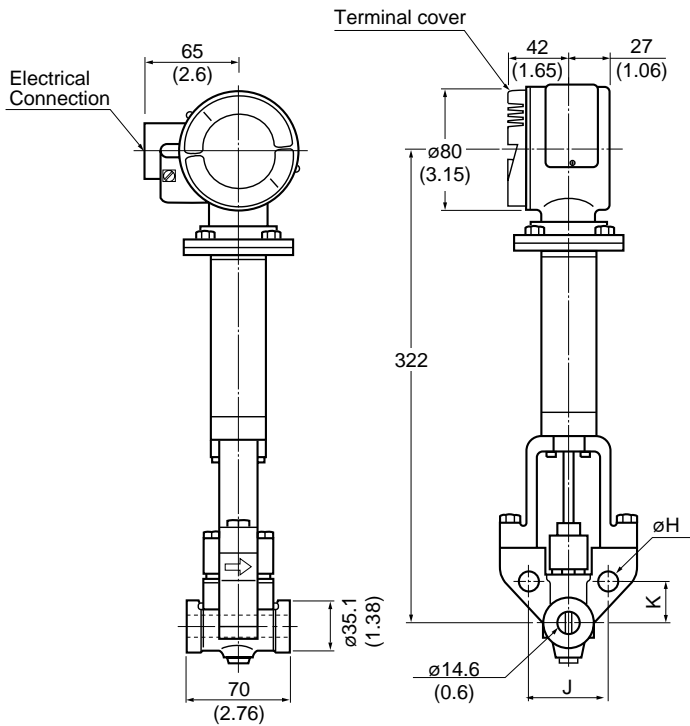

Hole diameter (H)

Pressure rating		Nominal dia		
		15mm(1/2 in)		
		K	J	øH
JIS	10K	24.7 (0.97)	49.5 (0.95)	13 (0.51)
	20K	24.7 (0.97)	49.5 (0.95)	13 (0.51)
	40K	28.3 (1.11)	56.6 (2.23)	17 (0.67)
ANSI JPI	Class150	21.4 (0.93)	42.7 (1.68)	14 (0.55)
	Class300	23.5 (0.93)	47.1 (1.85)	14 (0.55)
	Class600	23.5 (0.93)	47.1 (1.85)	14 (0.55)
DIN	PN10/40	23 (0.91)	46 (1.81)	13 (0.51)

Fig41

■ Vortex Flow Detector (/HPT, /LPT)

● Flange Type

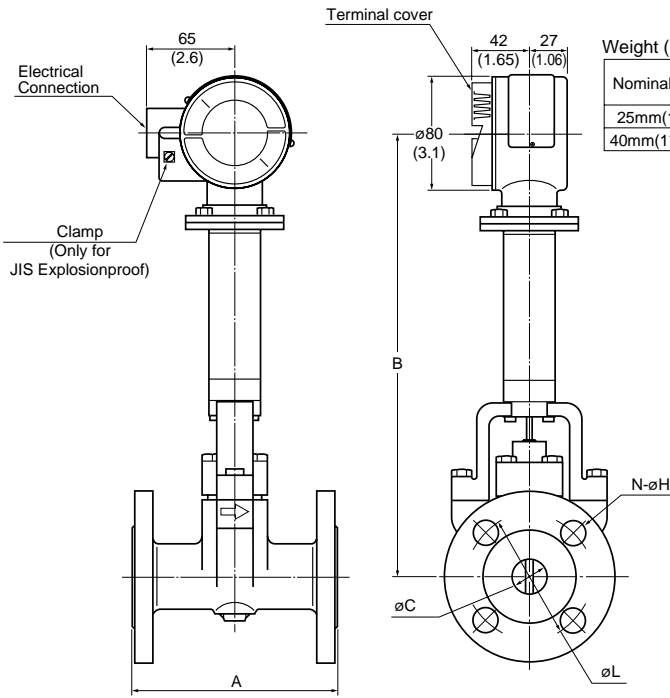

Weight (kg)

Nominal dia.	JIS Flange			ANSI Flange, JPI Flange			DIN	
	10K	20K	40K	Class150	Class300	Class600	PN10/40	PN64/100
25mm(1 in)	6.8(15.0)	7.0(15.4)	8.5(18.7)	6.5(14.3)	7.1(14.3)	7.6(15.6)	6.8(15.0)	9.5(20.94)
40mm(1 1/2 in)	8.1(17.85)	8.3(18.3)	11.8(26.0)	8.0(17.6)	9.2(17.6)	11.2(20.3)	8.7(19.18)	12.7(27.78)

Nominal dia.	A	B	øC
25mm(1 in)	150(5.9)	324(12.8)	25.7(1.0)
40mm(1 1/2 in)	150(5.9)	331(13.0)	39.7(1.6)

Center circle dia. (L)/Number of bolt holes (N)/Hole dia. (H)

Nominal dia.	25mm(1 in)			40mm(1 1/2 in)		
	øL	N	øH	øL	N	øH
JIS	10K	4	19	105	4	19
	20K	4	19	105	4	19
	40K	4	19	120	4	23
ANSI JPI	Class150	4	15.7	98.6	4	15.7
	Class300	4	19	114.3	4	22.4
	Class600	4	19	114.3	4	22.4
DIN	PN10/40	4	14	110	4	18
	PN64/100	4	18	125	4	22

Fig42

■ Vortex Flow Detector (/HPT, /LPT)

● Flange Type

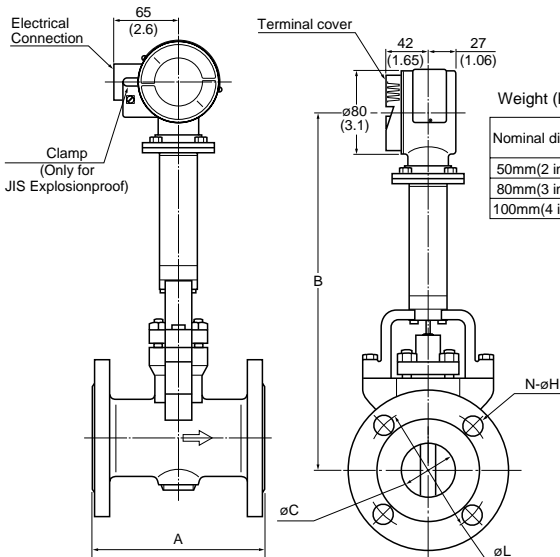

Nomina dia.	A	B	øC
50mm(2 in)	170(6.69)	353(13.9)	51.1(2.01)
80mm(3 in)	200(7.87)	370(14.6)	71.0(2.80)
100mm(4 in)	220(8.66)	385(15.2)	93.8(3.69)

* A = 240 mm for ANSI Class 600 and JPI Class 600

Weight (kg)

Nominal dia.	JIS			ANSI, JPI			DIN			
	10K	20K	40K	Class150	Class300	Class600	PN10/16	PN25/40	PN64	PN100
50mm(2 in)	10.0(22.05)	11.5(25.35)	14.2(31.30)	11.6(25.57)	13.1(28.88)	14.7(32.40)	11.2(24.69)	11.2(24.69)	14.2(31.31)	15.1(33.29)
80mm(3 in)	17.3(38.14)	19.9(43.87)	25.3(55.77)	19.9(43.87)	23.7(52.24)	25.3(55.78)	19.3(42.55)	19.9(43.87)	24.0(52.91)	26.9(59.30)
100mm(4 in)	22.7(50.05)	26.7(58.87)	38.0(87.77)	27.3(60.18)	35.8(78.92)	50.7(111.76)	23.1(50.93)	27.3(60.19)	32.9(72.53)	39.6(87.30)

Center circle dia. (L)/Number of bolt holes (N)/Hole dia. (H)

Nominal dia.	50mm(2 in)			80mm(3 in)			100mm(4 in)		
	øL	N	øH	øL	N	øH	øL	N	øH
JIS	10K	4	19	150	8	19	175	8	19
	20K	8	19	160	8	23	185	8	23
	40K	8	19	170	8	23	205	8	25
ANSI JPI	Class150	4	19	152.4	4	19	190.5	8	19
	Class300	8	19	168.2	8	22.4	200.2	8	22.4
	Class600	8	19	168	8	22.4	216	8	25.4
DIN	PN10/16	4	18	160	8	18	180	8	18
	PN25/40	4	18	160	8	18	190	8	22
	PN64	4	22	170	8	22	200	8	26
	PN100	4	26	180	8	26	210	8	30

Fig43

■ Vortex Flow Detector (/HPT)

● Flange Type

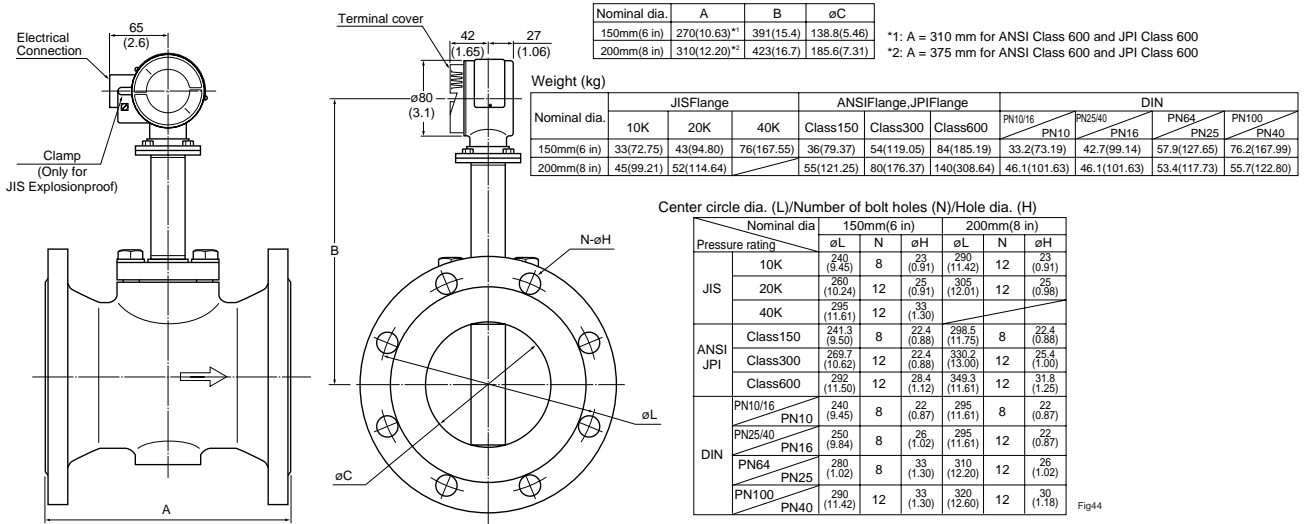

■ Vortex Flow Detector (/HPT, /LPT)

● Wafer Type

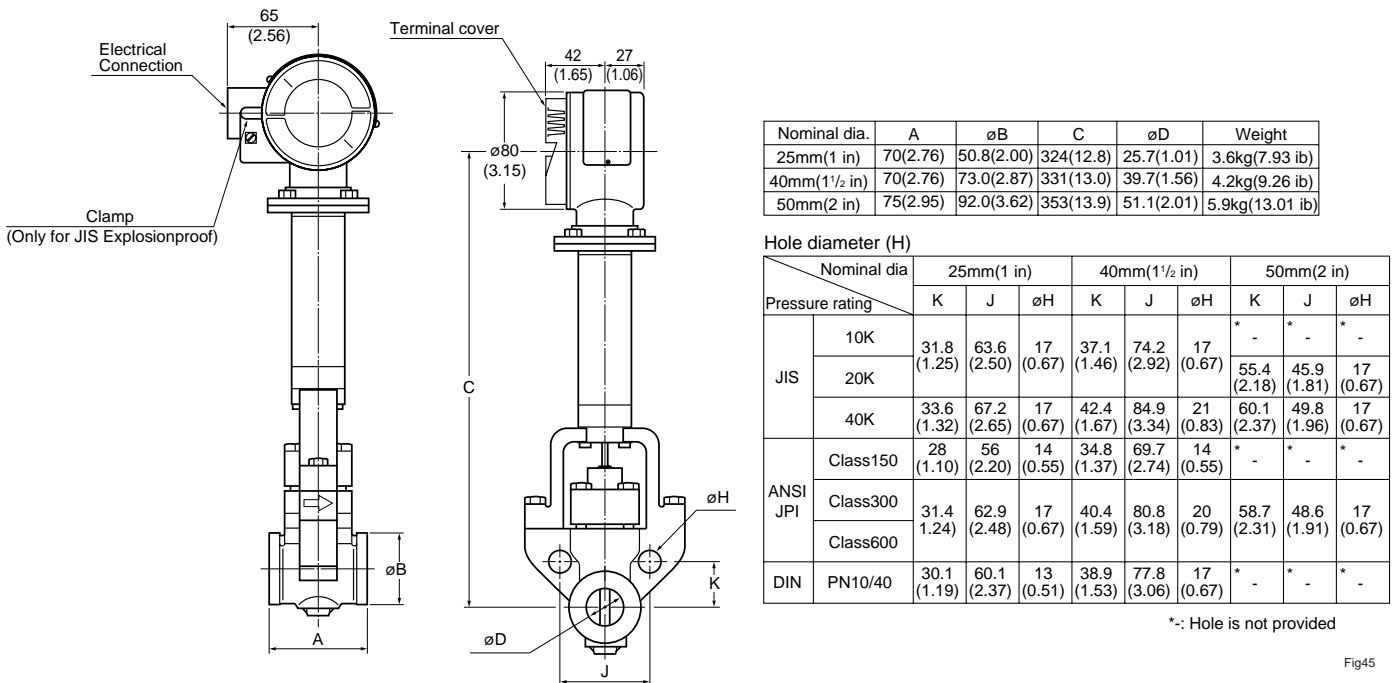

■ Vortex Flow Detector (/HPT, /LPT)
● Wafer Type

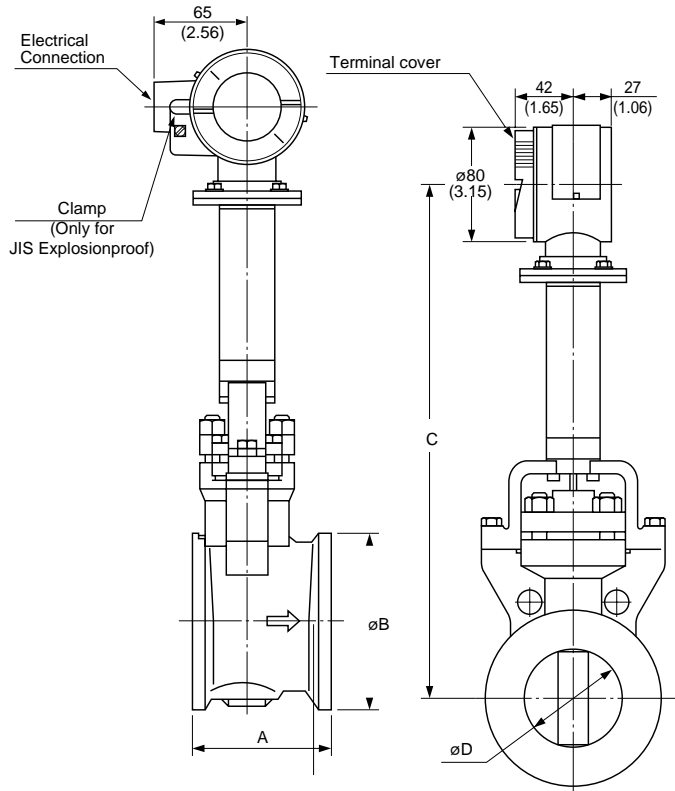

Nominal dia.	A	ϕB	C	ϕD	Weight
80mm(3 in)	100(3.94)	127.0(5.00)	370(14.6)	71.0(2.79)	9.3kg(20.50 lb)
100mm(4 in)	120(4.72)	157.2(6.19)	385(15.2)	93.8(3.69)	12.7kg(28.00 lb)

Hole diameter (H)

Pressure rating	80mm(3 in)			100mm(4 in)		
	K	J	ϕH	K	J	ϕH
JIS	10K	69.3 (2.73)	57.4 (2.26)	17 (0.67)	80.8 (3.18)	67.0 (2.64)
	20K	73.9 (2.91)	61.2 (2.41)	21 (0.83)	85.5 (3.37)	70.8 (2.79)
	40K	78.5 (3.09)	65.1 (2.56)	21 (0.83)	94.7 (3.73)	78.5 (3.09)
ANSI JPI	Class150	*	*	*	88.0 (3.46)	72.9 (2.87)
	Class300	77.7 (3.06)	64.4 (2.54)	20 (0.79)	92.5 (3.64)	76.6 (3.02)
	Class600	77.7 (3.06)	64.4 (2.54)	20 (0.79)	99.7 (3.93)	82.6 (3.25)
DIN	PN10/16	73.9 (2.91)	61.2 (2.41)	17 (0.67)	83.1 (3.27)	68.9 (2.71)
	PN25/40	73.9 (2.91)	61.2 (2.41)	17 (0.67)	87.8 (3.46)	72.7 (2.86)

*: Hole is not provided.

Fig46

■ Vortex Flowmeter (/CRC)
● Integral and Wafer Type

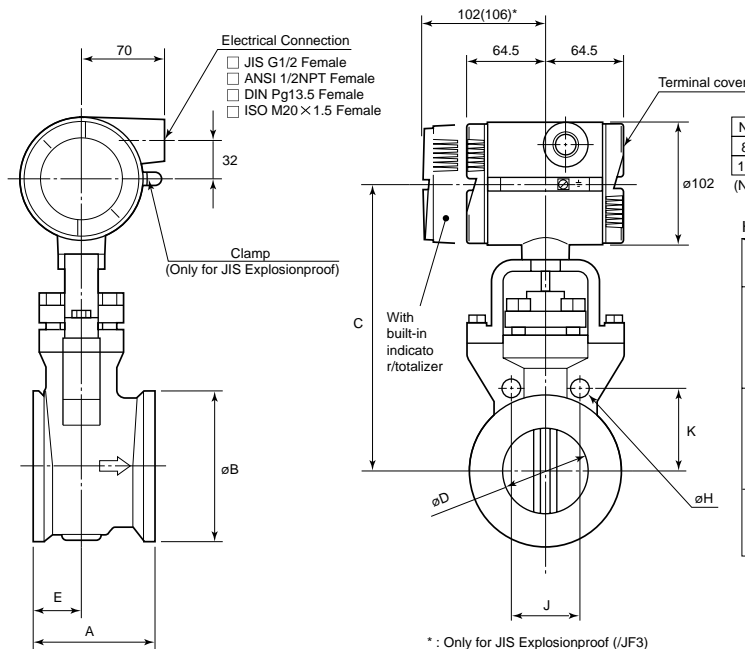

Nominal dia.	A	ϕB	C	ϕD	E	Weight(kg)
80mm(3 in)	100(3.94)	127.0(5.00)	239(9.41)	71.0(2.80)	40(1.57)	9.6(21.16)
100mm(4 in)	120(4.72)	157.2(6.19)	254(10.00)	93.8(3.69)	50(1.97)	13.0(28.66)

(Note) For flowmeters with built-in indicator/totalizer, add 0.4 kg(0.9lb)

Hole diameter (H)

Pressure rating	80mm(3 in)			100mm(4 in)		
	K	J	ϕH	K	J	ϕH
JIS	10K	69.3 (2.73)	57.4 (2.26)	17 (0.67)	80.8 (3.18)	67.0 (2.64)
	20K	73.9 (2.91)	61.2 (2.41)	21 (0.83)	85.5 (3.37)	70.8 (2.79)
	40K	78.5 (3.09)	65.1 (2.56)	21 (0.83)	94.7 (3.73)	78.5 (3.09)
ANSI JPI	Class150	*	*	*	88.0 (3.46)	72.9 (2.87)
	Class300	77.7 (3.06)	64.4 (2.54)	20 (0.79)	92.5 (3.64)	76.6 (3.02)
	Class600	77.7 (3.06)	64.4 (2.54)	20 (0.79)	99.7 (3.93)	82.6 (3.25)
DIN	PN10/16	73.9 (2.91)	61.2 (2.41)	17 (0.67)	83.1 (3.27)	68.9 (2.71)
	PN25/40	73.9 (2.91)	61.2 (2.41)	17 (0.67)	87.8 (3.46)	72.7 (2.86)

*: Hole is not provided

Fig47

■ Vortex Flowmeter (/CRC)
● Remote and Wafer Type

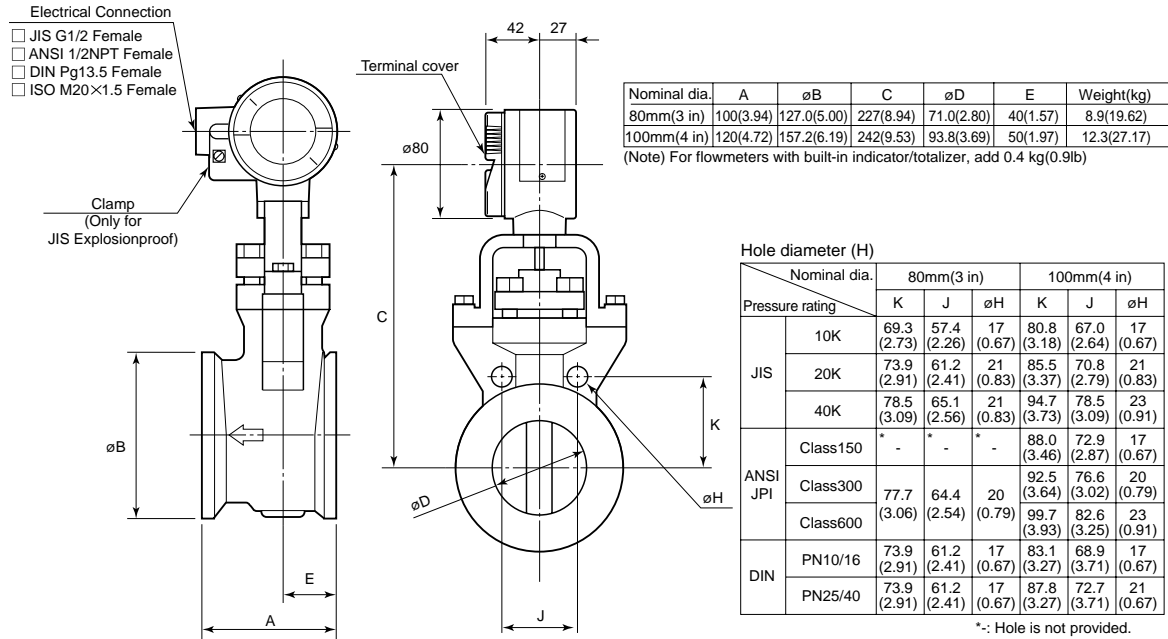
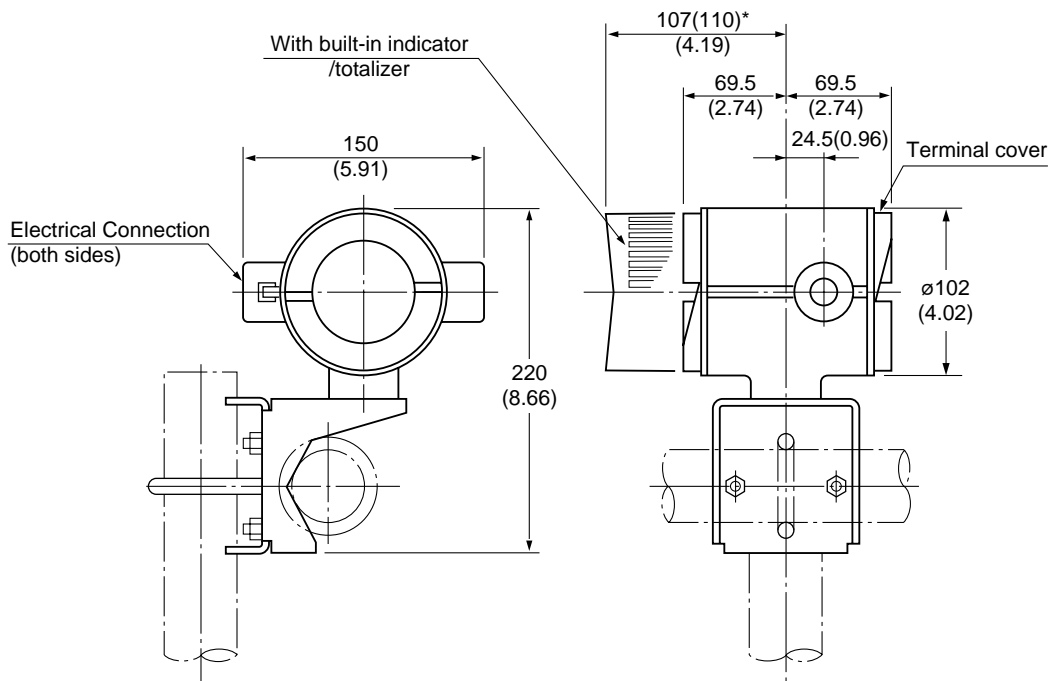

Fig48

Converter of Vortex Flowmeter



*: Only for JIS Explosionproof (/JF3)

Fig49

● Signal Cable for Remote Type

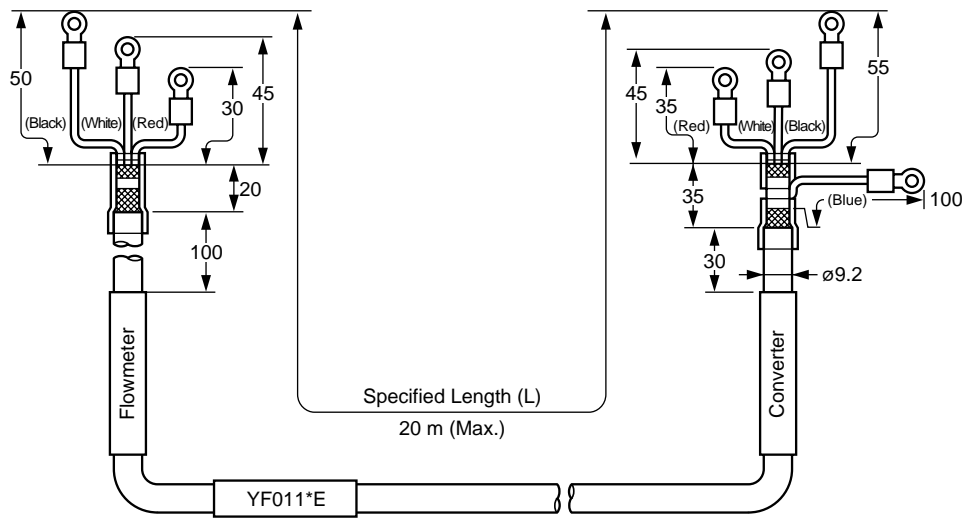

Cable Color and Terminal

Color	Terminal
Red	A
White	B
Black	C
Blue	G

■ Terminal Configuration and Terminal Wiring

● Integral Type

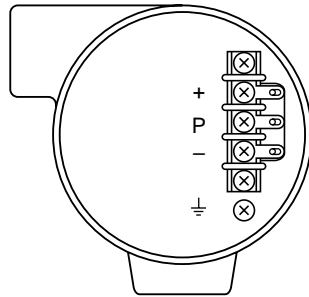

Integral Converter Type

+	4 to 20mA DC Output Power Supply and Output Signal Terminals
-	Voltage Pulse Output
+ - P	> Power Supply Terminals > Pulse Output Terminals
⏏	Ground Terminal

● Remote Type (Terminal Case)

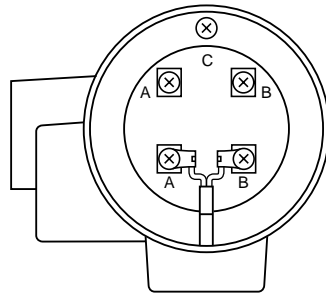

Remote Converter Type (Terminal)

A B	Output Terminals to Vortex Flow Converter.
C	Connect to the Signal Cable C Terminal.

Note: Use Model YF011 Signal Cable.

● Remote Type (Converter)

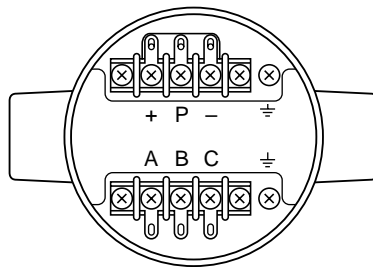

Remote Converter Type (Converter)

A B C	Input Terminals to Vortex Flowmeter
+	4 to 20mA DC Output Power Supply and Output Signal Terminals
-	Voltage Pulse Output
+ - P	> Power Supply Terminals > Pulse Output Terminals
⏏	Connect to the Signal Cable G Terminal.

Note: Use Model YF011 ... *D Signal Cable.

■ Flameproof Packing Adapter (Option code /G11, /G12)

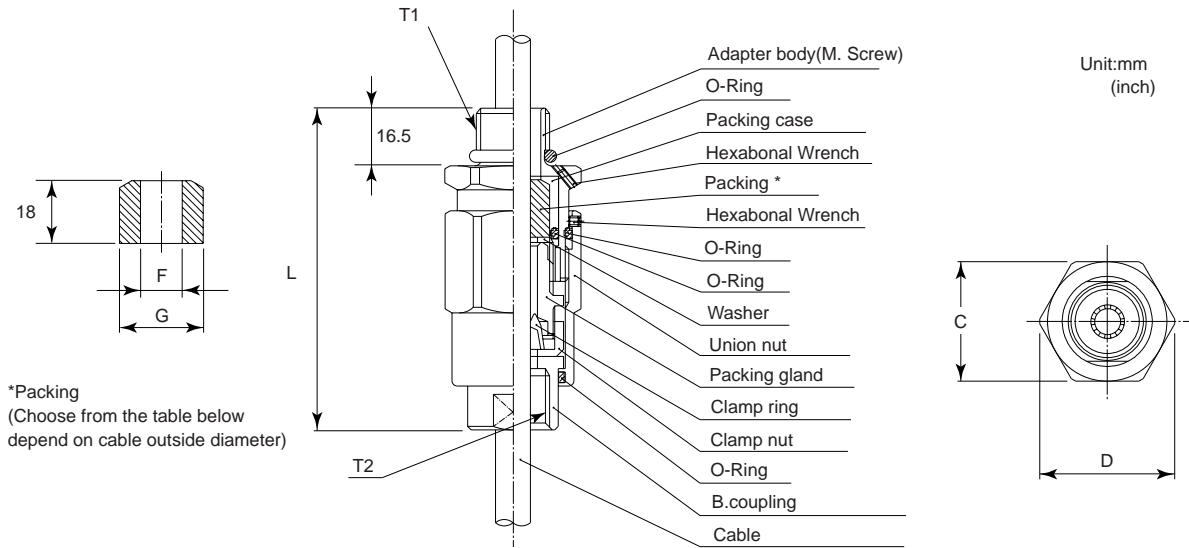

*Packing
(Choose from the table below depend on cable outside diameter)

Size					Cable outer diameter	Packing dimensions		Identification mark	Weight (kg)
T1	T2	C	D	L		F	G		
G 1/2	G 1/2	35 (1.37)	39 (1.52)	94.5 (3.69)	φ8 to φ10 (φ0.31 to φ0.39)	φ10 (φ0.39)	φ20 (φ0.78)	16 8-10	0.26 (0.57)
					φ10 to φ12 (φ0.39 to φ0.47)	φ12 (φ0.47)		16 10-12	

Fig50

==== OPERATING INSTRUCTIONS =====

Specify the following when ordering :

1. Model and suffix codes.
2. Flow conditions
 - a. Fluid name, or Gas composition
 - b. Maximum scale reading, normal flow rate and minimum flow rate.
 - c. Maximum and normal operating temperatures.
 - d. Maximum and normal operating pressures.
 - e. Density at operating conditions.
Density of gas at standard conditions.
 - f. Viscosity at normal operating conditions (wet gas only).
 - h. Devitation factor at normal operating conditions (gas only).

==== RELATED INSTRUMENTS =====

- YFCT Flow Computing Totalizer.....See GS 1P1B1-E
- BARD Safety Barrier.....See GS 1B4S1-E
- SDBT Distributor.....See GS 1B4T1-E
See GS 1B4T2-E

FIELD MOUNTING INDICATOR

- (4914,4915).....See GS 1S1B1-E

==== RELATED METERIAL =====

- How to fill in YEWFLO Vortex Flowmeter. TI 1F2B4-01E
- YEWFLO Vortex Flowmeter Sizing (for *E)TI 1F2B4-02E
- YEWFLO Vortex Flowmeter Guide Book TI 1F2B4-03E
- YEWFLO Vortex Flowmeter TI 1F2A4-01E
- The age of the vortex is here Bull 1F2A3-11E
- YFCT Flow Computing Totalizer Operation and Parameter TI 1P1B1-03E
- YFCT Flow Computing Totalizer Auxiliary Data Entry Guide TI 1P1B1-11E