

# General Specifications

## DAQSTATION CX1000 Control and Measurement Station



GS 04L31A01-01E

### OVERVIEW

CX1000 is a controller with up to 6 ch measurement channels and up to 2 embedded loops. By using Ethernet interface equipped as standard feature, it is possible to send e-mails, monitor the site remotely on the Web, and make an FTP-based file transfer.

CX1000 comes standard with control and measurement screens; CX1000 operation screen can be used with program-less. By using PV math/SP math or logic math for each loop, CX1000 can be used for variety purposes.



### DISPLAY SPECIFICATIONS

- Display unit: 5.5-inch TFT color LCD (320 × 240 pixels)
- Display color: Selectable from 12 options for trend/bar graphs
- Background color: Selectable from white or black

#### Display

##### Control Screen

- Control group display
  - Number of loops covered: 4 max.
  - Number of displays: 4 (4 groups)
  - Display style: Controller, faceplate and hybrid style
  - DIO operation: Display on control screen
    - Setting DIO number: up to 12
  - Tuning display: Capable of assigning up to 21 parameters
- Overview screen: Control loop up to 6 loops
  - Measurement ch: up to 6 ch
  - DIO status: up to 6
- DI/DO status display: DI display number: up to 6
  - DO display number: up to 6
- Program control display:
  - Simultaneously displays the program operation status and current PV readings.
- Number of loops covered: 2 Max.
- Number of displays: 1 (1 group)
- Display update interval:
  - Digital readings: 1 sec
  - Program readings: Same as the trend update interval
- Program event display
  - Group display:
    - Up to 5 events and their names display
  - All display: All event display
  - All time events display:
    - All time events and the some events names display
  - All PV events display:
    - All PV events and the some events names display
- Internal SW status screen: Display number: 18

Number of display channels/kinds (Max)

Input Type	Number of Channels Covered
Internal loops	6 (Two loops x PV, SP and OUT readings)
Green series communication channels	12 (Four loops x PV, SP and OUT readings)
Measurement channels	6
Computation channels (option)	12

#### Measurement Screen

- Trend screen
  - Direction of view: Vertical or horizontal
  - Number of channels covered: 6 max./screen (group)
  - Number of trend views on all channels: 36 max.
  - Number of displays: 6 (6 groups)
  - Line width: Selectable from 1, 2 and 3 pixels
  - Screen update interval:
    - Selectable from 1 min, 2 min, 5 min, 10 min, 20 min, 30 min, 1 hr, 2 hr, 4 hr, and 10 hr/div
- Bar graph display:
  - Direction of view: Vertical or horizontal
  - Number of channels covered:
    - 6 channels max./display (group)
  - Number of displays: 6 (6 groups)
  - Scale: Configurable within a range from 4 to 12
    - Reference position = Edge or midpoint
  - Update interval: 1 sec
- Digital display:
  - Number of channels covered:
    - 6 channels max./display (group)
  - Number of displays: 6 (6 groups)
  - Update interval: 1 sec

Overview display:  
 18 channels max. (including computation channels) for measurement  
 Measured values and alarms for all channels.

Information display:  
 Jumps to the trend view of a data item selected by the cursor.

Alarm summary display: Display the list of alarms.

Event summary display:  
 Display the list of events.

Control operation summary screen:  
 Display the list of control operation statuses.

Message summary display:  
 Display the list of message and time.

Memory summary display:  
 Display the list of internal memory.

Tag display: Tag names for measurement channels (up to 16 alphanumeric characters)  
 Tag names for control loops and DIO (up to 8 alphanumeric characters)  
 Tag comments for control loops and DIO (up to 8 alphanumeric characters)

Other on-display elements:  
 Memory status, scale values (0%, 100% - can be turned on/off), scales (6 scales max.), grid (selectable from a range of 4 to 12 divisions) with hour:min indications, date and time (year/month/day and hour:minute:second indications), trip line (selectable from 1-, 2- and 3-pixel thickness options), messages (of up to 16 characters and 8 types), and alarm marks

Data reference function:  
 Display the retrieved data.  
 Display format: Bisectional or full-screen view  
 Time axis: Can be upscaled, downscaled, and scrolled.

Automatic screen switching  
 Switching interval  
 5 sec, 10 sec, 20 sec, 30 sec, or 1 min

LCD back light saver function  
 Timer setpoint: 1, 2, 5, 10, 20 or 60 min

## ■ CONTROL FUNCTIONS

### Control mode

Singleloop, cascade control, and loop control with PV switching.

### Control computation functions

Continuous PID control, Relay on/off control, time proportional PID control  
 PID parameter: 8 sets/loop for each control mode  
 Points of zone PID switching: 6 max.  
 "Super" function (overshoot prevention)  
 Tracking functions: SP tracking PV tracking  
 Anti-reset windup function  
 (over-integration prevention function)  
 Control interval: 250, 500 or 1000 ms

### Operation mode switching

- Switching among remote, local, and program modes
- Switching among manual, auto, and cascade modes
- Run/stop mode switching  
 Stop mode: Outputs the preset output value.
- Switching between Execute/Stop options of auto-tuning  
 Principle of auto-tuning: Limit cycle method

#### PID Control Method

PID Control mode	Operation mode	Operating status	PID control method	Bump of control output
Standard PID control mode	Fixed point control operation	Local and cascade control except cascade secondary loop control	PV derivative type PID	Yes
		Remote or secondary cascade loop control	Deviation derivative type PID	Yes
	Programmed control operation	Local and cascade control except secondary cascade loop control, hold or soak	PV derivative type PID	Yes
		During programmed operation (without status of hold or soak) or secondary cascade loop control	Deviation derivative type PID	Yes
Fixed point Control Mode	Fixed point control operation	Local and cascade control except cascade secondary loop control	PV derivative type PID	Yes
		Remote or cascade secondary cascade loop control	PV derivative type PID	Yes
	Programmed control operation	Local, hold and soak	PV derivative type PID	No
		Programmed operation (without status of hold) or secondary cascade loop control	PV derivative type PID	Yes

\*The secondary cascade loop is secondary loop of cascade control that is selected from the cascade mode (auto, manual, cascade)

### Setting ranges of control parameters

- Proportional band: 0.1 to 999.9%
- Integral time: 1 to 6000 sec, or off (for manual reset)
- Derivative time: 1 to 6000 sec, or off
- On-off control hysteresis width:  
 0.0 to 100.0% of measurement range
- Preset output value: -5.0 to 105.0% of output  
 (Provided in case of control computation being stopped, PV input being in a burnout state, or instrument input being abnormal)
- Output limiter:  
 Setting range: -5.0 to 105.0% for both high/low limits
- Shutdown function:  
 Can provide a manipulated output of up to 0 mA when in manual mode operation with 4-20 mA output (shuts down the output for values smaller than -5.1%).
- Output rate-of-change limiter:  
 Off, or a value from 0.1 to 100.0%/sec

## ● PV math/SP math function

Math expression can be assigned to PV and SP of each loop

Type of computation:

Four arithmetic operations, square root, absolute, common logarithm, exponential, power, relational operations (<, ≤, >, ≥, =, ≠), logic operations (AND, OR, NOT, XOR), Statistical operations (average, Max. Min.-Min.) conditional operations( [expression 1 ? expression 2 ? expression 3 ])

Note: Conditional operators can be used with the other operands together

Available operands for arithmetic operations:

Measurement data, measurement math data, embedded/external control data, communication input data, constant W01-W12, control input data, control output DIO, expansion module DIO, measurement remote input, internal switch

Operation limitation: Within 120 characters

Available operands in an expression: less than 35

In error case: Over/Under selection

Over: Upper limit of PV/SP value

Under: Lower limit of PV/SP value

## ● Logic Math

Available number of operations: Up to 12

Operation type:

Relational operations (<, ≤, >, ≥, =, ≠), logic operations (AND, OR, NOT, XOR), conditional operations( [expression 1 ? expression 2 ? expression 3 ])

Note: Conditional operators can be used with the other operands together

Available operands in an expression:

Same as PV math/SP math operands

## ● Internal SW

Number of available internal SW: 18

Non-hold type only

## ● Analog retransmission

Output type: Current output (4-20mA, 0-20mA, 20-4mA, 20-0mA), time proportional voltage pulse output, time proportional relay output

Display/record: Data is recorded/displayed as out value

Note: The loop of analog retransmission mode can calculate PID Math.

Available math operation: Same as PV math/SP math

Available operands: Same as PV math/SP math

## ■ ALARM FUNCTIONS

### ● Control Alarm

Types of control alarm: PV high limit, PV low limit, high limit of deviation, low limit of deviation, deviation high and low limits, deviation within high and low limits, SP high limit, SP low limit, OUT high limit, and OUT low limit

Other alarm type: Fault diagnosis, fail output

Stand-by action: Turns off PV/SP alarm from starting control until steady condition

Alarm output: 6 points/ 2 loops (transistor output 4 points, relay output 2 points)

Alarm setting: 4 types/ loop

Hysteresis: Can set each alarm setting

Display: The status is shown in the digital display in case of alarm. A common alarm indication is also displayed.

The alarm behavior: non-hold or hold-type selectable.

### ● Measurement Alarm

Number of alarm levels:

Up to four levels for each channel

Alarm types: High and low limits, differential high and low limits, high and low rate-of-change limits and delay high and low

Alarm delay time: 1 to 3600 s

Interval time of rate-of-change alarms:

The measurement interval times 1 to 15

Display: The alarm status (type) is displayed in the digital value display area upon occurrence of an alarm. A common alarm indication is also displayed.

The alarm behavior: non-hold or hold-type selectable.

Hysteresis: On (0.5% of display span)/off selectable (common to all channels and alarm levels)

Outputs: Number of points: 6 points (optional)

Relay action: Energized/deenergized and hold/non-hold selectable.

Memory: The times of alarm occurrences/ recoveries, alarm types, etc. are stored in the memory. (Up to 120 latest alarm events are stored.)

Alarm display/record cancel function:

In alarm occurrence, alarm display/record can be selected

## ■ INPUT SECTION

### ● Specifications Common to Control and Measurement Inputs

Thermocouple burnout:

Switchable between ON/OFF options of detection on a channel basis.

Switchable between burnout upscale/ downscale options

Burnout condition:

Normal: less than 2kΩ

Burnout: more than 10kΩ

Integral time of A/D converter:

Select from the options of 20 ms (50 Hz), 16.7 ms (60 Hz) 100 ms (50/60 Hz) and AUTO (automatic switching between 20 ms and 16.7 ms depending on the power supply frequency).

**● Control Input**

Number of inputs:  
 5 max. (depends on model and control mode)  
 Input interval: 250, 500 or 1000 ms, synchronized with the control period  
 Input type: DC voltage (DCV), thermocouple (TC), resistance temperature detector (RTD), DC current (DCA) with external shunt resistor  
 Linear scaling:  
 Input ranges capable of scaling: Thermocouple (TC), resistance temperature detector (RTD), and DC voltage (DCV)  
 Available range of scaling: -30000 to 30000, with a span smaller than 30000  
 Decimal point position: Selectable by user  
 Unit: Can be set by user, using up to 6 characters.  
 Burnout of standardized signals:  
 Burnout can be detected

**Configuration of input/output signal**

Measurement input computation:  
 Input processing, square root extraction (0.0 to 5.0% low level cutoff), 10-segment linealizer, and 10-segment linearizer biasing, and bias addition (from -100.0 to 100.0% of measuring range), first order lag filter (time constant: 1 to 120 sec, or off)  
 Auxiliary computation input:  
 Input processing, square root extraction (0.0 to 5.0% low level cutoff), bias addition (from -100.0 to 100.0% of measuring range), ratio multiplication (0.001 to 9.999), and first order lag filter (time constant: 1 to 120 sec, or off)

**Table of Control Input Specifications**

Input type	Range	Measuring range
DCV - applicable to linear scaling only	20 mV	-20.00 to 20.00 mV
	60 mV	-60.00 to 60.00 mV
	200 mV	-200.0 to 200.0 mV
	2 V	-2.000 to 2.000 V
	6 V	-6.000 to 6.000 V
	20 V	-20.00 to 20.00 V
	50 V	-50.00 to 50.00 V
TC	R <sup>*1</sup>	0.0 to 1760.0°C
	S <sup>*1</sup>	0.0 to 1760.0°C
	B <sup>*1</sup>	0.0 to 1820.0°C
	K <sup>*1</sup>	-200.0 to 1370.0°C
	E <sup>*1</sup>	-200.0 to 800.0°C
	J <sup>*1</sup>	-200.0 to 1100.0°C
	T <sup>*1</sup>	-200.0 to 400.0°C
	N <sup>*1</sup>	0.0 to 1300.0°C
	W <sup>*2</sup>	0.0 to 2315.0°C
	L <sup>*3</sup>	-200.0 to 900.0°C
	U <sup>*3</sup>	-200.0 to 400.0°C
	PLATINEL	0.0 to 1400.0°C
	PR40-20	0.0 to 1900.0°C
W3Re/W25Re	0.0 to 2400.0°C	
RTD <sup>*5</sup>	Pt100 <sup>*4</sup>	-200.0 to 600.0°C
	JPt100 <sup>*4</sup>	-200.0 to 550.0°C
Standardized signal	1 to 5 V	1.000 to 5.000 V

\*1: R, S, B, K, E, J, T, N : IEC584-1 (1995), DIN IEC584, JIS C1602-1995  
 \*2: W : W-5% Re/W-26% Re (Hoskins Mfg. Co.), ASTM E988  
 \*3: L : Fe-CuNi, DIN43710, U : Cu-CuNi - DIN43710  
 \*4: Pt100 : JIS C1604-1997, IEC751-1995, DIN IEC751-1996  
 JPt100 : JIS C1604-1989, JIS C1606-1989  
 \*5: Measuring current : i = 1 mA

**● Measurement input**

Number of inputs: 0 or 6  
 Measuring interval:  
 1 or 2 sec (2 sec, if the integral time of A/D converter is 100 ms)  
 Input type: DC voltage (DCV), thermocouple (TC), resistance temperature detector (RTD), Operation log (DI), DC current (DCA) with external shunt resistor

**Measurement Input Ranges and Measuring Ranges**

Input type	Input Range	Measuring Range
DCV	20 mV	-20.00 to 20.00 mV
	60 mV	-60.00 to 60.00 mV
	200 mV	-200.0 to 200.0 mV
	2 V	-2.000 to 2.000 V
	6 V	-6.000 to 6.000 V
	20 V	-20.00 to 20.00 V
	50 V	-50.00 to 50.00 V
TC	R <sup>*1</sup>	0.0 to 1760.0°C
	S <sup>*1</sup>	0.0 to 1760.0°C
	B <sup>*1</sup>	0.0 to 1820.0°C
	K <sup>*1</sup>	-200.0 to 1370.0°C
	E <sup>*1</sup>	-200.0 to 800.0°C
	J <sup>*1</sup>	-200.0 to 1100.0°C
	T <sup>*1</sup>	-200.0 to 400.0°C
	N <sup>*1</sup>	0.0 to 1300.0°C
	W <sup>*1</sup>	0.0 to 2315.0°C
	L <sup>*3</sup>	-200.0 to 900.0°C
	U <sup>*3</sup>	-200.0 to 400.0°C
	PLATINEL	0.0 to 1400.0°C
	PR40-20	0.0 to 1900.0°C
W3Re/W25Re	0.0 to 2400.0°C	
RTD <sup>*5</sup>	Pt100 <sup>*4</sup>	-200.0 to 600.0°C
	JPt100 <sup>*4</sup>	-200.0 to 550.0°C
DI	DCV input	OFF: lower than 2.4 V ON: 2.4 V or higher
	Contact input	ON/OFF states

\*1: R, S, B, K, E, J, T, N : IEC584-1 (1995), DIN IEC584, JIS C1602-1995  
 \*2: W : W-5% Re/W-26% Re (Hoskins Mfg. Co.), ASTM E988  
 \*3: L : Fe-CuNi, DIN43710, U : Cu-CuNi - DIN43710  
 \*4: Pt100 : JIS C1604-1997, IEC751-1995, DIN IEC751-1996  
 JPt100 : JIS C1604-1989, JIS C1606-1989  
 \*5: Measuring current : i = 1 mA

Filter function: Switchable between ON/OFF options of moving average on a channel basis; selectable from 2 to 16 times for the frequency of moving average calculation

**Computation**

Difference computation: Allows for calculation of difference between any two channels.  
 Input ranges capable of difference computation:  
 DCV, TC and RTD

**Linear scaling:**

Input ranges capable of scaling: DCV, TC, RTD  
 Available range of scaling: -30000 to 30000  
 Decimal point position: Selectable by user  
 Engineering unit: Can be set by user up to 6 characters.

**Square root scaling:**

Input ranges capable of scaling: DCV  
 Available range of scaling: -30000 to 30000  
 Decimal point position: Selectable by user  
 Engineering unit: Can be set by user up to 6 characters.

## ■ STORAGE FUNCTIONS

External storage medium:

Select from the following options when ordering.

- 3.5" floppy disk (2HD)
- PCMCIA ATA flash memory card
- Zip disk

### Storage functions:

Store internal control loops' data (PV, SP and OUT of internal loops), Green series communication loops' data (PV, SP and OUT of connected Green series communication), measurement ch data, and computation ch data.

PV, SP and OUT of internal loops: Assigned from 101 to 106 ch

PV, SP and OUT of Green series communication channels: Assigned from 201 to 212 ch

Data on 18 channels among the above-noted channels, as well as 6 measurement channels and 12 computation channels, are stored as data files.

#### Types of Recorded Data

Data Type	Channel/Loop/System Included in Recording	Data Item
Display data (i.e., data for graphical screen views)	Measurement channels/computation channels/internal control loops/Green series communication	Minimum/maximum values during time-out period
Event data	Measurement channels/computation channels/internal control loops/Green series communication	Measured values for each sampling period
TLOG data	Measured/computation data	TLOG data values at TLOG time-out
Report data	Measurement channels/computation channels	Values of channels on an hourly/daily/weekly/monthly basis
Manual sampling data	Measurement channels/computation channels/internal control loops/Green series communication loops	ASCII-format data input with keys or remotely
Alarm summary data	Measurement channels/computation channels/internal control loops/Green series communication loops	Information on the occurrence/cancellation of alarms on channels being recorded
Event summary data	Events caused for the system	Occurrence/cancellation of time/PV events
Control mode summary data	System (program operation), or each internal control loop or green series communication loops for all other cases	Run/stop, local/remote, and manual/auto/cascade modes switching, hold/cancellation of hold of programs, wait/cancellation of wait

### Method of saving data

Saving method: Manual or automatic selectable

Manual saving: Data saving by inserting external memory medium

Automatic saving:

Display data: Periodic saving (10 min to 31 days) or key operation to external memory

Event data: In case of trigger free...Periodic saving (3min to 31 days) or key operation to external memory

In case of using trigger...Save the data when sampling is finished

Data saving period:

Display data file:

Linked with the waveform span rate

Event file: Linked with the specified sampling period

Event file sampling period:

Selectable from 1, 2, 5, 10, 30, 60, 120, 300, and 600 s

Measurement data files:

(1) Event file

Instantaneous values are saved at a specified sampling interval.

(2) Display data file

The maximum and minimum values found during the display update interval are saved.

Combination of files to be created

(1) Event file (triggers only) and display data file

(2) Display data file only

(3) Event file only

Data format: Binary

Data size per channel:

Display data: Control data = 4 bytes/data item

Measurement data = 4 bytes/data item

Computation data = 8 bytes/data item

Event data: Control data = 2 bytes/data item

Measurement data = 2 bytes/data item

Computation data = 4 bytes/data item

Sampling time:

Tested for manual saving on a file.

When creating a display data file only:

Test conditions:

2 control loops, 6 measurement channels, 8 computation channels, 30 min/div display update interval (data save interval of 60 sec)

Number of data items per channel = 1,200,000 bytes/(2 × 4 bytes + 6 × 4 bytes + 8 × 8 bytes) = approx. 12,500\*

\* Specified as 100,000 data items maximum.

Sampling time per file = 12,500 × 60 sec = 750,000 sec = approx. 9 days

When creating an event file only:

Test conditions:

2 control loops, 6 measurement channels, 8 computation channels, 1-sec data save interval

Number of data items per channel = 1,200,000 bytes/(2 × 2 bytes + 6 × 2 bytes + 8 × 4 bytes) = approx. 25,000\*

\* Specified as 120,000 data items maximum.

Sampling time per file = 25,000 (1 sec = 25,000 sec) = approx. 7 hours

When creating both a display data file and an event file:

Display data file size = 900,000 bytes, where a maximum number of data items is 75,000

Event data file size = 300,000 bytes, where a maximum number of data items is 30,000

Note that the number of files created varies depending on the capacity of storage medium if a Zip drive or an ATA memory card is used.

Examples of sampling time

Test conditions:  
2 control loops, 6 measurement channels, and no computation on channels

Display Data File Only

Display Update Interval (Min/Div)	1	5	20	30	60	240
Data save interval (sec)	2	10	40	60	120	480
Sampling time (Approx.)	13 hrs	69 hrs	11 days	17 days	34 days	138 days

Event Data File Only

Data save interval (sec)	1	5	30	120
Sampling time (Approx.)	13 hrs	69 hrs	17 days	69 days

Display Data File and Event Data File

Display Data File

Display Update Interval (Min/Div)	1	5	20	30	60	240
Data save interval (sec)	2	10	40	60	120	480
Sampling time (Approx.)	10 hrs	2 days	8 days	13 days	26 days	104 days

Event Data File Only

Data save interval (sec)	1	5	30	120
Sampling time (Approx.)	3 hrs	17 hrs	4 days	17 days

Manually sampled data

Storage trigger: Key input or contact input

Data format: ASCII

Maximum number of data items stored: 50

TLOG data (only when equipped with computation option)

Storage trigger: Data at the moment TLOG timeout is saved.

Report data (only when equipped with report option)

Report type: Hourly report, daily report, a combination of hourly reports and daily reports, a combination of daily and weekly reports, and a combination of daily and monthly reports

Data format: ASCII

Trigger functions:

Event file: Select the mode from FREE, TRIG and ROTATE options.

Display data and event files:

Select the mode from TRIG and ROTATE options.

Display copy functions:

Copying method:

By means of key operation

Data format: PNG

Output destination:

External storage medium or communication output

■ **HARDWARE**

● **Construction**

Angle of mounting:

Backward tilt of up to 30°; no tilt is allowed on either side, however.

Thickness of mounting panel: 2 to 26 mm

Material: Case = Steel plate

Bezel = Polycarbonate

Color of coating: Case = Pale cobalt blue

(equivalent to DIC 16 edition 102)

Bezel = Light charcoal gray

(equivalent to Munsell 10B3.6/0.3)

Front panel: Dust- and drip-proof (compliant to IEC529-IP65, NEMA No. 250 Type 4 [except for icing tests])

External dimensions:

144 mm (W) × 144 mm (H) × 223.6 (D) mm

CX1000: 2.6 kg

CX1006: 3.0 kg

CX1200: 3.0 kg

CX1206: 3.1 kg

● I/O Signal Specifications

**Control Output**

Current output  
 Number of outputs: 2/2 loops  
 Output signal: 4-20 mA DC or 0-20 mA DC  
 Load resistance: 600 Ω max.  
 Output accuracy: ±0.1% of span (1 mA or greater)  
 Temperature drift: ±200 ppm/°C (tested for output section)

Voltage pulse output  
 Number of outputs: 2/2 loop  
 Output signal: On-state voltage: 12 V DC  
 Load resistance: 600 Ω min.  
 Resolution: 0.1%

Relay contact output  
 Number of outputs: 2/2 loops  
 Output signal: NC, NO, COM  
 Contact rating: 250 V AC/3 A or 30 V DC/3 A (resistive load)

**Contact input**

Number of inputs: 6/2 loops  
 Input signal: Voltage-free contact or open collector (TTL or transistor)  
 Input condition:  
 On-state voltage: 0.5 V max. (30 mA DC)  
 Off input leakage current: 0.25 mA max.  
 Input configuration:  
 Photocoupler-isolated (two-point common)

**Contact output**

Number of relay outputs: 2/2 loops  
 Relay contact rating: 250 V AC/1 A or 30 V DC/1 A (resistive load)  
 Number of transistor outputs: 4/2 loops  
 Transistor contact rating: 24 V DC/50 mA

**Analog input section**

Number of control inputs:  
 5 (number of contacts depends on model and control mode)  
 Input interval: 250, 500 or 1000 ms  
 Number of measurement inputs:  
 6 (DCV, TC and DI inputs are isolated)  
 Input interval: 1 or 2 sec

● Installation Environment Standards

Normal operating conditions:  
 Ambient temperature: 0 to 50°C (5 to 40°C, if a floppy disk or Zip drive is in operation)  
 Ambient humidity: 20 to 80% RH (at 5 to 40°C)  
 Vibration: 10 to 60 Hz, 0.2 m/s<sup>2</sup>  
 Mechanical shock: Not allowed.

Noise:  
 Normal mode noise (50/60 Hz):  
 DC current (DCA): The peak value including a signal component is less than 1.2 times the measuring range.  
 Thermocouple (TC): The peak value including a signal component is less than 1.2 times the thermal electromotive force.  
 Resistance temperature detector (RTD):  
 50 mV max.  
 Common mode noise voltage (50/60 Hz):  
 250 V AC rms max. for all ranges  
 Inter-channel maximum noise voltage (50/60 Hz):  
 250 V AC rms max.

Warm-up time: 30 min minimum after power-on  
 Altitude: 2000 m max.  
 Transport and storage conditions:  
 Ambient temperature: -25 to 60°C  
 Ambient humidity: 5 to 95% RH (non-condensing)  
 Vibration: 10 to 60 Hz, 4.9 m/s<sup>2</sup>  
 Mechanical shock: 392 m/s<sup>2</sup> max. (when housed in a package)

**Safety and EMC Standards**

Safety standards:  
 Certified as conforming to CSA22.2 No. 1010.1; compliant to EN61010-1  
 Installation category (overvoltage category) II\*<sup>1</sup>, pollution degree 2\*<sup>2</sup>  
 \*1: Installation category (overvoltage category):  
 Refers to a numerical index for defining transient overvoltage levels. (This standard also includes the standard of impulse withstanding voltage and applies to electrical equipment powered by stationary equipment such as a switch-board.)  
 \*2: Pollution degree:  
 Refers to the degree of deposition of a solid, liquid or gas substance that degrades withstanding voltage or surface resistivity. (This standard only applies to normal indoor atmospheres – nonconductive pollution.)

EMC standard: Compliant to EN61326-1

**Power Supply Section**

Supply voltage: 100 to 110 V AC ±10% or 200 to 220 V AC ±10%  
 Supply frequency: 50 Hz ±2% or 60 Hz ±2%  
 Power consumption:

Supply Voltage	When LCD Saver Is On	When in Normal Operation	Maximum
100 V AC	Approx. 20 VA	Approx. 23 VA	39 VA
240 V AC	Approx. 29 VA	Approx. 32 VA	51 VA

**Isolation**

Insulation resistance:  
 20 MΩ min. between each terminal and ground (at 500 V DC)

Withstanding voltage:  
 Between power supply terminal and ground:  
 1500 V AC (50/60 Hz), 1 min  
 Between relay contact output terminal and ground:  
 1500 V AC (50/60 Hz), 1 min  
 Between measurement input terminal and ground:  
 1500 V AC (50/60 Hz), 1 min  
 Between measurement input terminals:  
 1000 V AC (50/60 Hz), 1 min  
 Between contact input terminal and ground:  
 500 V DC, 1 min  
 Between current output terminal and ground:  
 500 V AC (50/60 Hz), 1 min  
 Between voltage pulse output terminal and ground:  
 500 V AC (50/60 Hz), 1 min  
 Between transistor contact output terminal and ground:  
 500 V DC, 1 min  
 Grounding: Grounding resistance, less than 100 Ω  
 Control input terminals:  
 Isolated from other input/output terminals, with inter-channel isolation.  
 Measurement inputs:  
 Isolated from other input/output terminals, with inter-channel isolation (b terminal is common for optional RTD).

Voltage pulse control output terminals\*:  
 Not isolated from DC output terminals but isolated from other input/output terminals.  
 Current output terminals\*:  
 Not isolated from voltage pulse control output terminals but isolated from other input/output terminals.  
 Control output (relay) terminals\*:  
 Isolated from other input/output terminals.  
 Contact input terminals:  
 Not isolated from other contact input terminals but isolated from other input/output terminals.  
 Contact output (relay) terminals:  
 Isolated from other input/output terminals.  
 Contact output (transistor) terminals:  
 Not isolated between transistor but isolated from other input/output terminals.  
 Alarm output terminals:  
 Isolated from other input/output terminals.  
 Alarm remote terminals:  
 Not isolated from DI but isolated from other input/output terminals.  
 RS-232C:  
 Not isolated from case.  
 RS-422/485:  
 Isolated from other input/output terminals.  
 Ethernet:  
 Isolated from other input/output terminals.  
 Power terminals:  
 Isolated from other input/output terminals.  
 Grounding terminals:  
 At case potential.  
 \*: Control outputs have inter-loop isolation.

● **Standard Performance Data**

Input Type	Range	Measurement Accuracy (Digital Readings)	Max. resolution of digital display	
DC voltage (DCV)	20 mV	±(0.1% of rdg + 2 digits)	10 μV	
	60 mV		10 μV	
	200 mV		100 μV	
	2 V		1 mV	
	6 V		1 mV	
	20 V		10 mV	
	50 V		±(0.1% of rdg + 3 digits)	10 mV
Thermocouple (TC) - excluding the accuracy of reference junction compensation	R	±(0.15% of rdg + 1°C), where R and S = ±3.7°C over 0 to 100°C and ±1.5°C over 100 to 300°C; B = ±2°C over 400 to 600°C, and is not guaranteed for temperatures below 400°C.	0.1°C	
	S			
	B			
	K			±(0.15% of rdg + 0.7°C), where the accuracy is ±(0.15% of rdg + 1°C) over -200 to -100°C.
	E			±(0.15% of rdg + 0.5°C)
	J			±(0.15% of rdg + 0.5°C), where the accuracy is ±(0.15% of rdg + 0.7°C) over -200 to -100°C.
	T			
	N			±(0.15% of rdg + 0.7°C)
	W			±(0.15% of rdg + 1°C)
	L			±(0.15% of rdg + 0.5°C), where the accuracy is ±(0.15% of rdg + 0.7°C) over -200 to 100°C.
U				
PLATINEL	0.0 to 1400.0°C			
PR40-20		Not guaranteed over 0 to 450°C		
		±(0.9% of rdg + 16.0°C) over 450 to 750°C		
		±(0.9% of rdg + 6.0°C) over 750 to 1100°C		
W3Re/W25Re		±(0.9% of rdg + 2.0°C) over 1100 to 1900°C		
		±(0.3% of rdg + 2.8°C)		
Resistance temperature detector (RTD)	Pt100	±(0.15% of rdg + 0.3°C)		
	JPt100			

**Measurement/reading accuracy:**

Tested under the following conditions:

Standard operating conditions:

23 ±2°C, 55 ±10% RH

Supply voltage range:

90 to 132 V AC; 180 to 250 V AC

Supply frequency range:

50/60 Hz ±1% max.

Note: The accuracy performance is tested after a warm-up time of at least 30 min and in a location free from such adverse effects on the instrument's operation as mechanical vibration.

**Measurement accuracy during scaling:**

Measurement accuracy during scaling (digits)  
= measurement accuracy (digits) + 2 digits  
where the value is rounded up to the nearest whole number.

**Reference junction compensation:**

Switchable between INT (internal) and EXT (external) options (common to all channels).

**Reference junction compensation accuracy:**

±1.0°C for types R, S, B, W, PR40-20 and W3Re/W25Re

±0.5°C for types K, J, E, T, N, L, U and PLATINEL only (during measuring temperature that is no lower than 0°C)

**Maximum input voltage:**

±10 V DC (continuous) for 2 V DC or lower voltage ranges and TC input

±30 V DC (continuous) for 6 and 20 V DC voltage ranges

**Input resistance:**

10 MΩ min. for 2 V DC or lower voltage ranges and TC input

Approx. 1 MΩ for 6 V, 20 V, and 50 V DC voltage ranges

**External input resistance:**

2 kΩ max. for DCV and TC inputs

10 Ω max. per wire for RTD input (all three wires must have the same resistance)

**Input bias current: 10 nA max.**

Interference between channels:

120 dB (when external input resistance is 500 Ω and the level of input to other channels is 30 V)

Common mode rejection ratio:

120 dB (50/60 Hz ±0.1%, unbalanced 500 Ω input resistance; tested between negative input terminal and ground)

Normal mode rejection ratio:

40 dB (50/60 Hz ±0.1%)

**■ EFFECT ON OPERATING CONDITIONS****Ambient temperature:**

Variations for a temperature change of 10°C:

Within ±(0.1% of rdg. + 1 digit)

\* Excluding reference junction compensation errors ±(0.1% of rdg. + 2 digits) for RTDs

**Power supply variations:**

Power supply within range of 90 to 132, 180 to 250 V AC (frequency of 50/60 Hz): Within ± 1 digit

Variations for a change of ±2 Hz in rated power supply frequency (for power voltage of 100 V AC): Within ±(0.1% of rdg. + 1 digit)

**External magnetic field:**

Variations for an AC (50/60 Hz) or DC external magnetic field of 400 A/m: Within ±(0.1% of rdg. + 10 digits)

**Signal source resistance:**

Variations for a + 1 kΩ change in signal source resistance.

**(1) DC voltage range**

2 V DC and lower ranges: Within ±10 μV

6 V DC and higher ranges: Within -0.1% of rdg.

**(2) Thermocouple range**

Within ±10 μV (however, ±100 μV when burnout is specified)

**(3) RTD range (Pt100)**

I) Variation for a 10 Ω change in each wire (assuming all 3 wires have the same resistance): Within ±(0.1% of rdg. + 1 digit)

II) Variation due to 40-mΩ difference in resistance between lead wires (maximum difference between all wires): Approx. 0.1°C

**● Other Specification**

Clock: Provided with calendar function; can be synchronized by means of external contact

Clock accuracy:

±100 ppm, excluding a time lag (less than 1 sec) at the time of power-on

Key lock function:

Can be turned on or off; a password can be set for the function.

Login function:

The station can be logged in to by entering a user name, user ID and password. The station can be locked with a password.

■ COMMUNICATION FUNCTIONS

● Ethernet Communication

Medium: Ethernet (10BASE-T)  
 Basis protocol: SMTP, HTTP1.0, FTP, TCP, UDP, IP, ARP and ICMP  
 E-mail function:  
 Recipient address: 2 address groups (two or more addresses can be specified for each group using no more than 150 characters)  
 Types of message: The following pieces of information can be sent via e-mail; for each address group, a selection can be made as to whether or not to send the information.  
 Alarm inform: Inform in occurring alarm/canceling alarm  
 System inform: Inform in recovering power failure/inform the time of recovering, inform the rest of time before rewriting on inside memory (manual save mode), inform the rest of amount in reaching 90% of media volume (auto save mode)  
 Scheduled time inform: Inform the moment value at a certain time or interval  
 Report inform: Inform report data in report timeup (/M1 is equipped)  
 Web server function: Shows screen images, alarms, instantaneous values and other information using Browser software (Internet Explorer 5.0).  
 FTP client function: Transfers files automatically.  
 FTP server function: Acquires or deletes files, or manipulates directories from the host computer, and provides information on the remaining size of memory.  
 FTP server function: Manipulates directories in an external storage medium, outputs or deletes files from the medium, and provides information on the remaining size of memory.  
 Real-time monitor function: Real time monitoring CX data by communication (Yokogawa private protocol)  
 CX PC-UT gateway function: By using CX as gateway, external UT parameters can be set from PC.

● Serial Communication

This type of communication is used for ladder communication, digital indicating controller communication, and modbus communication.  
 Medium: EIA RS-232 (CX1xx0x-x-1-x)  
 EIA RS-422A/485 (CX1xx0x-x-2-x)  
 Protocol: Dedicated protocol or Modbus protocol  
 Synchronization: Start-stop synchronization  
 Communication method (RS-422A/485): Four-wire, half-duplex multi-drop connection (1:N, where N = 1 to 31)  
 Transfer rate: 1200, 2400, 4800, 9600, 19200, or 38400 bps  
 Data length: 7 or 8 bits  
 Number of stop bits: 1  
 Parity: ODD, EVEN or NONE  
 Overall communication distance (RS-422A/485): 1.2 km  
 Communication mode: ASCII for input/output of control and setting data  
 ASCII or binary for output of measured data  
 Modbus communication:  
 Operating mode: RTU MASTER or RTU SLAVE  
 RTU MASTER: Perform communication with temperature controller  
 RTU SLAVE: Outputs measured/computed data, alarm statuses, and so on.  
 Ladder communication: Data input/output by means of BCD code

● Green Series Communication

This function is for communicating with Yokogawa M&C's UT series. Supported controller models are UT3x0, UT3x1, UT4x0, UT5x0, UT750, and other specific models (Only Read and record support).

● Ladder Communication

Ladder communication is a communication protocol used to communicate with Programmable Logic Controllers (PLCs) that are capable of ladder communications.

**■ OPTIONS**

● **Program Setting Functions (/PG1, /PG2)**

**Program setting functions**

Number of program patterns: 4 (/PG1), 30 (/PG2)  
 Number of segments per program pattern: 99 max.  
 Number of program segments:  
 300 max. (as the sum of segments for all program patterns)  
 Number of program events: 800 max.  
 Number of program repetitions: 999 max. or infinite  
 Segment time: 0 min:1 sec to 99 hr:59 min:59 sec  
 Start/stop of program pattern:  
 A program pattern can be started(RUN), stopped(RESET), held(Hold) or advanced by means of contact input or instrument operation.

Switching among program patterns:  
 A program pattern can be switched to another by means of contact input or instrument operation.

Advance function: Forcibly moves the program to the next segment

Wait function:  
 Wait time: Off, or 0 min:1 sec to 99 hr:59 min:59 sec  
 Wait zone: 0.0 to 100.0% of the span of measurement input range

**PID parameters switching**

Segment PID selection: PID-parameter numbers being used can be selected on a segment basis  
 Zone PID selection: PID parameter sets are switched depending on the value of the applied PV input

**Time event:**

The progress status of a program pattern is provided by means of contact output.(ON/OFF)  
 Number of events set: 16 max. per segment  
 Output: Provided after the lapse of a specified time from the moment of segment switchover.  
 Range of time lapse: 0 to 99 hr:59 min:59 sec

**PV event:**

Alarm function for measured values/deviations within a program pattern  
 Number of events set:16 max. per segment  
 Event type: PV high limit, PV low limit, high limit of deviation, low limit of deviation, deviation within high and low limits, SP high limit, SP low limit, Out high limit, Out low limit

**Control mode switching**

RESET/RUN switching for program operation: Run/stop status of program operation  
 Hold/non-Hold options:  
 The progress of program operation can be placed in a Hold state or non-Hold state while in the Run status of a program.

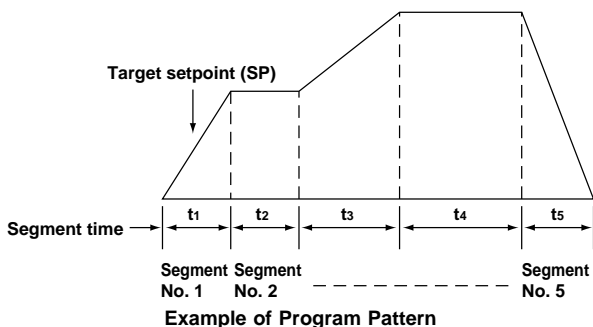

● **Measurement Alarm Output Relay (/A6, /A6R, /A4F, /A4FR)**

Number of outputs: 6 (/A6, /A6R, /A4F, /A4FR)  
 Number of inputs: 8 (for /A6R, A4FR option only)  
 Relay contact rating: 250 V DC/0.1 A (resistive load) or 250 V AC (50/60 Hz)/3 A  
 Output configuration: NO-C-NC (Energized-at-alarm/deenergized-at-alarm, AND/OR, and hold/non-hold actions are selectable)

**Remote Control (/A6R, /A4FR)**

The following types of control are possible by means of contact input (configurable for up to 8 types):

- Start/stop of memory (signal edge)
- External trigger input for event files (trigger of 250 ms or longer)
- Synchronization (adjusts the clock to an appointed time by means of contact input; trigger of 250 ms or longer)
- Start/stop of computation (signal edge)
- Resetting of computed data (250 ms or longer trigger)
- Manual sampling (250 ms or longer trigger)
- Message writing (configurable for up to 8 messages; 250 ms or longer trigger)
- Load setting (configurable for up to 3 loads; 250 ms or longer trigger)
- Alarm acknowledgment (of 250 ms or longer trigger)

**FAIL output/end-of-memory output (/A4F, /A4FR)**

The relay contact output on the rear panel indicates the occurrence of a system error, the rest of memory media.

**Manual save mode:**

Relay output before the specified time of starting overwriting inside memory (selectable from 1, 2, 5, 10, 20, 50, or 100 hours)

**Auto save mode:**

Relay output when the amount of memory media reaches 90%

**Relay contact rating:**

250 VDC/0.1 A (for resistance load) 250 VAC (50/60 Hz)/3 A

● **Batch Header Function (/BT1) :**

Batch number function are available.

**Batch number function:**

Batch number (max. 16 characters + 4 figures lot number) and comment (max. 32 characters × 3 lines) can be set in the operation mode.

Auto increment of serial number by each batch start is available.

Pre-set application name, supervisor name and manager name can be referred in the batch number entry display.

Data file : Following information are added to the display/event data file as headers.

- User name
- Application name
- Supervisor name
- Manager name
- Batch number
- comment

● **Mathematical Functions (/M1)**

With the “/M1” option, it is possible to show and record trend graphs/digital readings for the following types of computation on computation channels.

Number of computation channels: 12

Types of computation:

Standard computations:

Four fundamental arithmetic operations, square roots, absolute values, common logarithm, exponents, powers, relational operations (<, ≤, >, ≥, =, ≠), logical operations (AND, OR, NOT, XOR)

Statistical computations:

Average, maximum, minimum, and total values of time-series data

Moving average computation:

A moving average calculation is performed on the results of computation.

Constants: Up to 30 constants can be set as necessary.

Communication-based digital input:

This input can be applied to computational expressions other than statistical ones.

Number of communication-based digital data values: 30

Remote input:

A remote status (0/1) can be used in a computational expression.

Number of remote-input data values: 8

Report functions:

Report type:

Hourly report, daily report, a combination of hourly and daily report, a combination of daily and weekly reports, and a combination of daily and monthly reports

Type of computation:

Average, maximum, minimum, total

Data format: ASCII

● **Three-legs Isolated RTD Input (/N2)**

The “/N2” option is an RTD input, the RTD of which has electrically isolated A, B and b terminals.

● **24 V DC/AC Power Supply (/P1)**

Specifications of the “/P1” option are as follows:

Rated supply voltage:

24 V DC/AC

Operating supply voltage range:

21.6 to 26.4 V DC/AC

Withstanding voltage:

500 V AC between power supply terminal and ground

Power consumption:

**Power Consumption**

Supply voltage	When LCD Saver Is On	When in Normal Operation	Maximum
24 V AC	Approx. 12 VA	Approx. 14 VA	23 VA
24 V AC (50/60 Hz)	Approx. 20 VA	Approx. 23 VA	37 VA

**Relation between Contact Inputs and Modules**

Contact Input Functions	Alarm/A6R 8 DI	Alarm/A4FR 8 DI	Control output module 6 DI	Remarks
Start and stop of memory	●	●	●	
Trigger	●	●	●	
Alarm acknowledgment	●	●	●	
Setting of time	●	●	●	
Start and stop of computation	●	●	●	
Computation reset	●	●	●	
Manual sample	●	●	●	
Load setting 1 to 3	●	●	●	
Messages 1 to 8	●	●	●	
Snapshot	●	●	●	
Stop control operation of all loops			●	
Start control operation of all loops			●	
SP switching*1			●	Contact input is common to all loops
Control stop/start			●	For cascade control, registration is allowed only for loop 2
Remote/local			●	For cascade control, registration is allowed only for loop 1
Automatic/manual operation			●	It is not available for cascade control
Automatic operation for cascade control			●	
Manual operation for cascade control			●	
Cascade switching			●	
Control with PV switching*1			●	
Start and stop of program operation			●	• 0 to 4bit can be used
Hold			●	• The following actions are executed to the pattern which is input by pattern selection DI.
Advance			●	Start and stop of program operation, Hold, Advance
Pattern selection*1			●	

\*1: It is not available for contact output (DO) and internal switch.

Relation between Contact Inputs and Modules

	Alarm /A6	Alarm /A6R	Alarm /A4F	Alarm /A4FR	Control Output module
Measurement alarms (channels 1 to 6 and channels 31 to 42)	●	●	●	●	●
Control alarms (channels 101 to 106)					●
PV event, time event, and pattern event					●
FAIL			●	●	● *1
Self-diagnostics					● *2
End of memory relay			●	●	

\*1: Output from DO001

\*2: Output from DO002

## ■ APPLICATION SOFTWARE

### ● DAQSTANDARD

System requirements:

- OS: Windows 98/Me/NT4.0/2000/XP
- Processor: MMX Pentium/166 MHz or superior (Pentium II/266 MHz or any other superior processor is recommended.)
- Memory: 32 MB min. (64 MB or larger memory is recommended)
- Disk device: CD-ROM drive compatible with Windows 98/Me/NT4.0/2000/XP
- Hard disk capacity: Free space of at least 10 MB (100 MB or larger free space is recommended)
- Display unit: A model provided with a display module compatible with Windows 98/Me/NT4.0/2000/XP and capable of handling at least 32000 colors (a display module capable of handling at least 64000 colors is recommended)
- Printer: Compatible with Windows 95/98/Me/NT4.0/2000/XP; the printer driver must also be compatible with the OS.

Main functions (as a package):

Configuration software:

External storage medium:

Configures the medium or sets it in set mode.

Configuration via communication:

Configures the station, excluding the communication setting (IP address), or sets it in set mode.

Data viewer:

Number of channels covered for display: 32 per group; 30 groups max.

Display functions:

Waveform views, digital readings, circular graphics, lists, TLOG views, report views, etc.

File connection display:

This function concatenates files created separately during continuous data acquisition because of auto-saving or power failure, and shows the concatenated file on the display (can concatenate files of up to 1,000,000 data items).

Section computation:

Maximum, minimum, average, rms value, p-p value

Data conversion:

This function converts the data format to ASCII, Lotus 1-2-3, or Excel.

Printout:

The data viewer prints replayed data.

■ MODELS AND SUFFIX CODES

(Style: S3)

Model	Suffix Code	Option Code	Remarks
<b>CX1000</b>			DAQSTATION CX1000 (Embedded loops: 0 loop, Measurement channels: 0ch)
External storage medium	-1		Floppy disk drive
	-2		Zip disk drive provided with 100 MB medium
	-3		ATA flash memory card provided with medium
Communication port	-0		Ethernet
	-1		RS-232C communication interface (including Modbus master/slave protocol functions)* <sup>1</sup> and Ethernet.
	-2		RS-422A/485 communication interface (including Modbus master/slave protocol functions)* <sup>1</sup> and Ethernet.
Language	-2		English
Option		/A4F	Measurement alarm (4 DO terminals, FAIL/end-of-memory output relays) <sup>2</sup>
		/A4FR	Measurement alarm with remote control (8 DI and 4 DO terminals, FAIL/end-of-memory output relays) <sup>2</sup>
		/BT1	Batch header function
		/M1	Computation functions (including report functions)
		/P1	24 V DC/AC power supply

\*1: Be sure to select /M1 and communication port (RS-232C or RS-422A/485) if you intend to use the Modbus master function.

\*2: Only one alternative choice is allowed.

(Style: S3)

Model	Suffix Code	Option Code	Remarks
<b>CX1006</b>			DAQSTATION CX1000 (Embedded loops: 0 loop, Measurement channels: 6ch)
External storage medium	-1		Floppy disk drive
	-2		Zip disk drive provided with 100 MB medium
	-3		ATA flash memory card provided with medium
Communication port	-0		Ethernet
	-1		RS-232C communication interface (including Modbus master/slave protocol functions)* <sup>1</sup> and Ethernet.
	-2		RS-422A/485 communication interface (including Modbus master/slave protocol functions)* <sup>1</sup> and Ethernet.
Language	-2		English
Option		/A6	Measurement alarm (6 DO terminals) <sup>2</sup>
		/A6R	Measurement alarm with remote control (8 DI and 6 DO terminals) <sup>2</sup>
		/A4F	Measurement alarm (4 DO terminals, FAIL/end-of-memory output relays) <sup>2</sup>
		/A4FR	Measurement alarm with remote control (8 DI and 4 DO terminals, FAIL/end-of-memory output relays) <sup>2</sup>
		/BT1	Batch header function
		/M1	Computation functions (including report functions)
		/N2	Three-wire isolated RTD (measurement channels)
	/P1	24 V DC/AC power supply	

\*1: Be sure to select /M1 and communication port (RS-232C or RS-422A/485) if you intend to use the Modbus master function.

\*2: Only one alternative choice is allowed.

(Style: S3)

Model	Suffix Code	Option Code	Remarks
<b>CX1200</b>			DAQSTATION CX1000 (Embedded loops: 2 loop, Measurement channels: 6ch)
<b>CX1206</b>			DAQSTATION CX1000 (Embedded loops: 2 loop, Measurement channels: 6ch)
External storage medium	-1		Floppy disk drive
	-2		Zip disk drive provided with 100 MB medium
	-3		ATA flash memory card provided with medium
Communication port	-0		Ethernet
	-1		RS-232C communication interface (including Modbus master/slave protocol functions)* <sup>1</sup> and Ethernet.
	-2		RS-422A/485 communication interface (including Modbus master/slave protocol functions)* <sup>1</sup> and Ethernet.
Language	-2		English
Option		/BT1	Batch header function
		/M1	Computation functions (including report functions)
		/N2	Three-wire isolated RTD (measurement channels) <sup>2</sup>
		/P1	24 V DC/AC power supply
		/PG1	Program control (4 program patterns) <sup>3</sup>
	/PG2	Program control (30 program patterns) <sup>3</sup>	

\*1: Be sure to select /M1 and communication port (RS-232C or RS-422A/485) if you intend to use the Modbus master function.

\*2: It can not be specified for CX1200 model.

\*3: Only one alternative choice is allowed.

Model	Description	OS
DXA200-02	DAQEXPLORER	Windows 98/Me/NT4.0/2000/XP
DXA200-02/XF1	DAQEXPLORER with auto file conversion function	
DXA310-011	DAQ-PharmBio	
DXA410-02	DAQOPC	Windows NT4.0
VA510-01-2	DAQLOGGER (400 channels)	Windows 95/98/NT4.0/2000/XP
VA510-02-2	DAQLOGGER (1000 channels)	
VA510-03-2	DAQLOGGER (1600 channels)	
VA520-01-2	DAQLOGGER Client (1600 channels)	

● Standard Accessories

Product	Quantity
Mounting brackets	2
Terminal screws	5
User's manual	1
Zip disk (100 MB); only if model has Zip disk drive function	1
ATA flash memory card (32 MB,CF+adapter ); only if model has ATA flash memory card function	1

● Optional Accessories

Product	Model (part) number	Specification
Shunt resistor (for screw input terminals)	415920	250 Ω ±0.1%
	415921	100 Ω ±0.1%
	415922	10 Ω ±0.1%
3.5-inch floppy disk	705900	2HD (10 units)
Zip disk	A1053MP	100 MB
Card adapter (not including CF card)	B9968NN	—
CF card (not including card adapter)	B9968NM	32 MB
	B9968NP	64 MB
	B9968NQ	128 MB
	B9968NR	256 MB
	B9968NS	512 MB
Mounting bracket	B9900BX	—

● Spare Parts

Control output module	CXA900-01	
-----------------------	-----------	--

**■ DIMENSIONS**

**Dimensions**

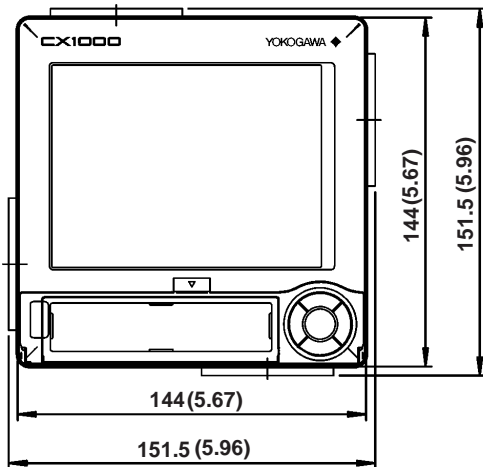
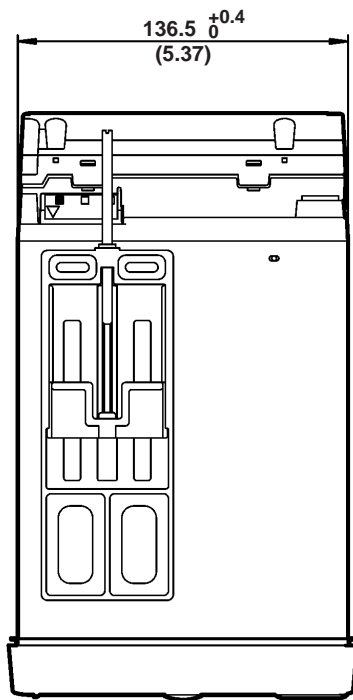

**Rear View**

Unit : mm  
(approx. inch)

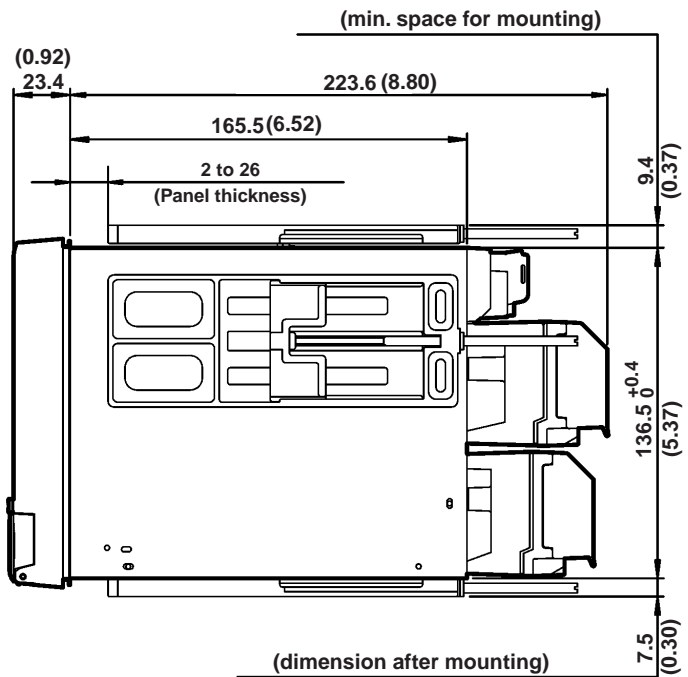
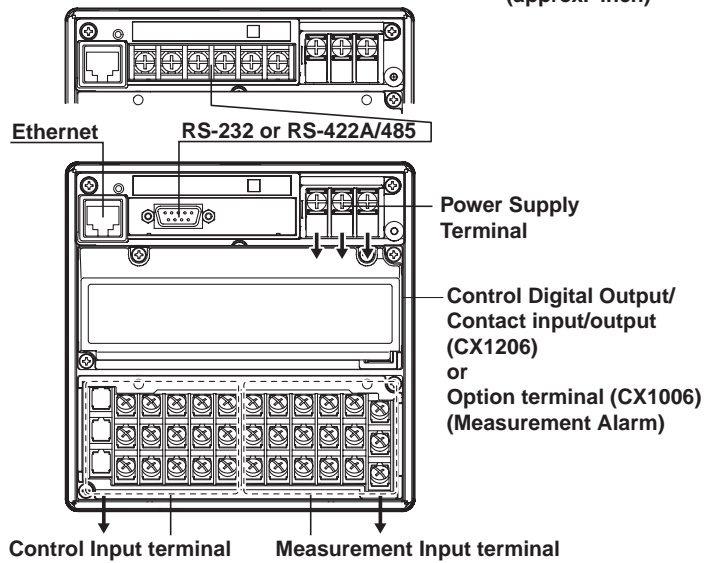

Note : If not specified, the tolerance is  $\pm 3\%$ .  
However, for dimensions less than 10 mm, the tolerance is  $\pm 0.3$  mm.

## Panel cutout

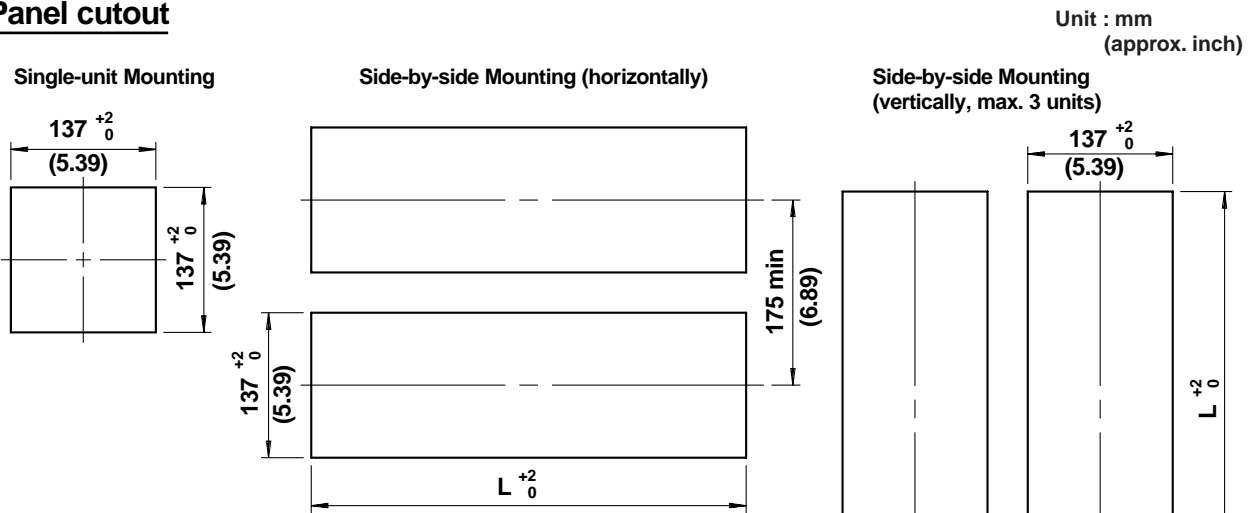

Unit : mm  
(approx. inch)

Units	L <sup>+2</sup> / <sub>0</sub> (mm)
2	282
3	426
4	570
5	714
6	858
7	1002
8	1146
9	1290
10	1434
n	(144 × n) – 6

Note : If not specified, the tolerance is ±3%. However, for dimensions less than 10 mm, the tolerance is ±0.3 mm.

## Power Supply Terminal

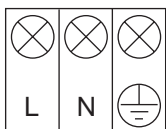

## RS-232 Terminal

12345  
6789

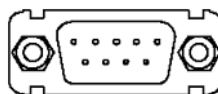

1	N.C.
2	RxD
3	TxD
4	DTR
5	GND
6	DSR
7	RTS
8	CTS
9	N.C.

## RS-422-A/485 Terminal

FG SG SDB SDA RDB RDA

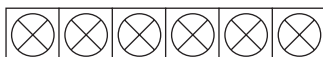

## FOUNDATION Fieldbus Terminal

FG SimEnable NC NC + -

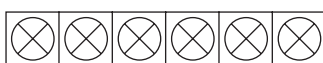

### Measurement Input Terminals

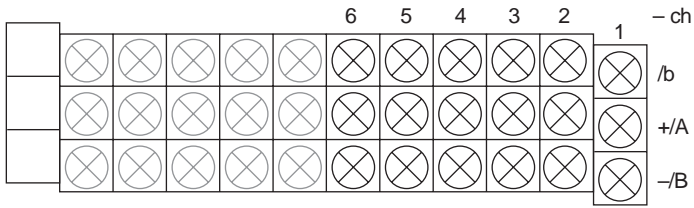

### Control input terminals

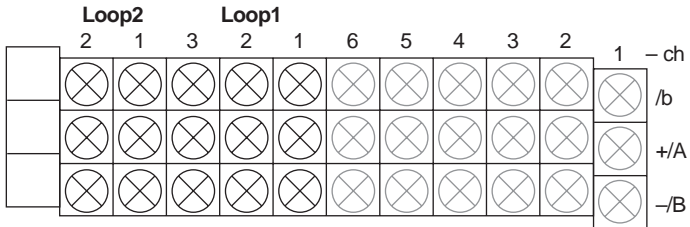

(RSP) PV (RSP) PV  
 PV (RSP) PV  
 PV2 PV1 (RSP) PV2 PV1

### Control output and contact I/O terminals

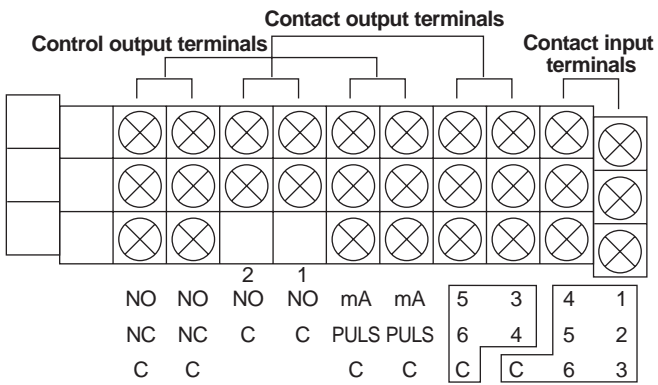

## Option Terminals (CX1006)

**/A6**

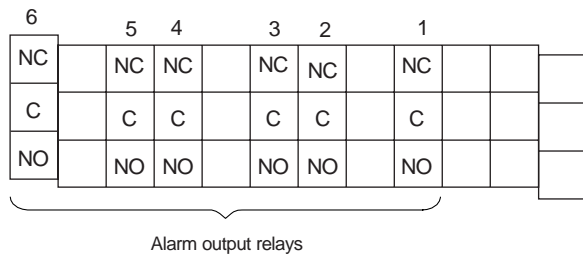

**/A6R**

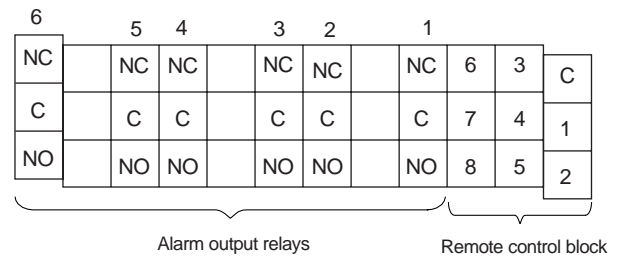

**/A4F**

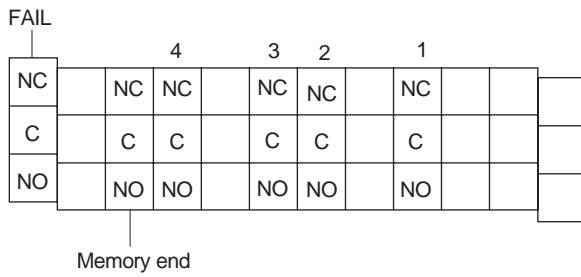

**/A4FR**

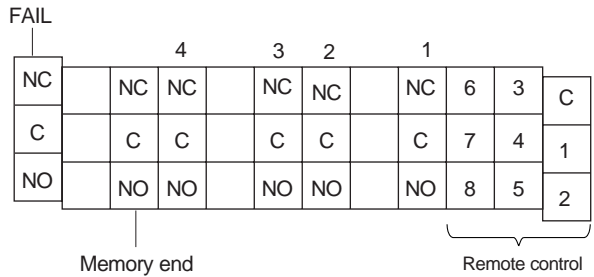

The TCP/IP software used in this product and the document for that TCP/IP software are based in part on BSD networking software, Release 1 licensed from The Regents of the University of California.

- Microsoft, MS and Windows are registered trademarks of Microsoft Corporation USA.
- Lotus and 1-2-3 are registered trademark of Lotus Development Corporation.
- MMX and Pentium are registered trademarks of Intel Corporation.
- Ethernet is a registered trademark of XEROX Corporation.
- Modbus is a registered trademark of AEG Schneider.
- The Logo mark of FOUNDATION™ Fieldbus and Fieldbus foundation are registered trademark of Fieldbus foundation
- Zip is a registered trademark of Iomega Corporation USA.
- Other company and/or product names are registered trade mark of their manufactures.