

## SPECIFICATIONS

### STANDARD FUNCTIONS

Function	Description
Periodic printout	Prints out date (year, month, day), time(hour, minute), chart speed, channel number, measured values, scale and recording color (pen model only) on the left side of chart at fixed intervals.
List printout	Prints out measuring ranges of each channel, recording spans, unit, and setting contents of alarm values, etc.
Alarm printout	Prints out channel number, alarm type, on or off time and markings when an alarm changes state.
Manual printout	Prints out measured results through panel keys or remote control (optional specification)
Setup list printout	Prints out setting contents of setup mode.
Digital display	The following are displayed depending on status. Recording on (channel number for dot model) Alarms End of chart paper (when /F1 of the optional functions is included) Battery end-of-life Displays contents for settings.
Analog indication	The same scales and pointers as with analog indication recorder are installed as standard.
Linear scaling	Linear scaling for DC voltage ranges from a 5 mV span up to 20 V.
Square-root scaling	Square-root scaling for DC voltage range from a 5 mV span up to 20 V.
Arbitrary setting function	Chart speed, alarm values, date and time can be easily set by key operation.
Memory backup	Preserves settings with a built-in lithium battery. (Life: Approximately 10 years at normal temperatures)
Side-by-side mounting	Panel-mounted side-by-side either vertically or horizontally.

### μRS1000/μRS1800 COMMON STANDARD FEATURES

#### Construction

**Mounting:** Flush Panel Mounting (Vertical), mounting may be inclined up to 30°, rear below front (with horizontal base)

**Panel thickness:** 2 to 26 mm

**Material:** Case: Drawn steel; Front door: Aluminum die casting

**Color:** Case and front door frame; Lamp black (Mansell 0.8Y2.5/0.4)

**Front door:** Splash and dust-proof door (Based on DIN 40050-IP 54.)

#### Input

**Input signals:** DCV ( $\pm 20$  mV to  $\pm 20$  V range)  
TC (Thermocouple)  
RTD (Resistance temperature detector)  
DCA (adding external shunt resistance [10,100 and 250Ω])

**Measurement range:** Range codes specified at ordering

Input type	Range code	Measurement range	Range code	Measurement range
DC voltage (DC V)	00	-20.00 to 20.00 mV	03	-6.000 to 6.000 V
	01	-200.0 to 200.0 mV	04	-20.00 to 20.00 V
	02	-2.000 to 2.000 V		
DC voltage (Linear scaling)	30	-20.00 to 20.000 mV	33	-6.000 to 6.000 V
	31	-200.0 to 200.0 mV	34	-20.00 to 20.00 V
	32	-2.000 to 2.000 V		
DC voltage (Square-root scaling)	40	-20.00 to 20.00 mV	43	-6.000 to 6.000 V
	41	-200.0 to 200.0 mV	44	-20.00 to 20.00 V
	42	-2.000 to 2.000 V		
TC	10	R 0 to 1760 °C		32 to 3200 °F *1
	11	S 0 to 1760 °C		32 to 3200 °F *1
	12	B 0 to 1820 °C		32 to 3308 °F *1
	13	K -200 to 1370 °C		-328 to 2498 °F *1
	14	E -200 to 800 °C		-328 to 1472 °F *1
	15	J -200 to 1100 °C		-328 to 2012 °F *1
	16	T -200 to 400 °C		-328 to 752 °F *1
	17	N 0 to 1300 °C		32 to 2372 °F *2
	18	W 0 to 2315 °C		32 to 4199 °F *3
	19	L -200 to 900 °C		-328 to 1652 °F *4
	1A	U -200 to 400 °C		-328 to 752 °F *4
	1B	PR20-40 0 to 1900 °C		32 to 3452 °F
	1C	Platinel 0 to 1400 °C		32 to 2552 °F
RTD	20	Jpt100 -200 to 550 °C		-328 to 1022 °F *5
	21	Pt100 -200 to 600 °C		-328 to 1112 °F *5
	22	Pt50 -200 to 600 °C		-328 to 1112 °F *5
	23	Cu10(GE) -200 to 300 °C		-328 to 572 °F
	24	Cu10(L&N) -200 to 300 °C		-328 to 572 °F
	25	Cu10(WEEED) -200 to 300 °C		-328 to 572 °F
	26	Cu10(BAILEY) -200 to 300 °C		-328 to 572 °F
	27	Cu10(*6) -200 to 300 °C		-328 to 572 °F
	28	Cu10(*7) -200 to 300 °C		-328 to 572 °F
	29	Cu25 -200 to 300 °C		-328 to 572 °F

\*1 R, S, B, K, E, J, T: ANSI, IEC 584, DIN IEC 584, JIS C 1602-1981

\*2 N: Nicrosil-Nisil, IEC 584, DIN IEC 584

\*3 W: W-5%Re-W.26%Re(Hoskins Mfg Co)

\*4 L: Fe-CuNi, DIN 43710, U: Cu-CuNi, DIN 43710

\*5 JPt100: JIS C 1604-1981, JIS C 1606-1989

Pt100: JIS C 1604-1989, JIS C 1606-1989

IEC 751, DIN IEC 751

Pt50: JISC1604-1981, JISC1606-1986

\*6  $\alpha = 0.00392$  @ 20°C

\*7  $\alpha = 0.00393$  @ 20°C

#### Recording

**Recording Method:** Pen-model: Disposable felt pens, plotter pen  
Dot-printing model: 6-color wire-dot recording  
User selects arbitrary speed from the following chart speed table using panel keys.

**Chart speed:**

##### Pen model (40 speeds)

(Unit: mm/h)

10	15	20	25	30	40	50	60	75	80
90	100	120	150	160	180	200	240	300	360
375	450	600	720	750	900	1200	1500	1800	2400
3000	3600	4500	4800	5400	6000	7200	9000	10800	12000

##### Dot-printing model (28 speeds)

(Unit: mm/h)

10	15	20	25	30	40	50	60	75	80
90	100	120	150	160	180	200	240	300	360
375	450	600	720	750	900	1200	1500		

**Chart feed accuracy:**  $\pm 0.1\%$  or less (for recording longer than 1000 mm, related to the grid of the chart paper)

#### Recording format (Digital printout)

**Channel printout:** Channel number with analog recording (Dot model only)

**Alarm printout:** Prints out alarm on or off markings, channel number, alarm type, and alarm on or off time (hour, minute) on the right side of chart.

**Periodic printout:** Prints out date (month, day) time (hour, minute), chart speed and measured data of each channel on the left side of chart.

- Channel number
- Measured value printout
- Scale printout: Scale marks in the 0 and 100% positions
- Color recording printout: Pen model only
- Date, time, and chart speed

**List printout:** Prints out a listing of range settings, alarm settings, etc.

**Manual printout:** Provides a digital printout of measurement results through remote control (optional function) or panel keys.

Analog recording temporarily stops.

**Setup list printout:** Prints out settings of setup mode.

## ■ Display

**Display method:** LED (7-segment, 2-digit)  
**Digital display:** The following are displayed depending on status.  
 Recording on (channel number for dot model); Alarms; End of chart paper (when / F1 of the optional functions is included), Battery end-of-life.  
**Scale plate:** Specified real graduation  
 Background ... white; Character/line/symbol ... black

## ■ Power supply

**Rated power voltage:** 100 to 240 V AC (automatic selection)  
**Usable power voltage ranges:** 90 to 132, 180 to 250 V AC  
**Rated power frequency:** 50/60 Hz (automatic selection)

## ■ Alarm

**Number of alarm levels:** Up to 4/channel (H/L limit)  
**Display:** Shared alarm indicator flashes in digital display

## ■ Others

**Clock:** Provided with a calendar function  
**Clock accuracy:** ±100 ppm; Does not include time lag (1 s or less) for each power source turned on or off  
**Memory backup:** Lithium battery to preserve setup parameters, battery is incorporated in the recorder to preserve setup parameters. Life: approximately 10 years (at room temperatures in standard model)

## Accessories:

Battery end-of-life display: In digital display  
 One Z-fold chart paper, one 6-color ribbon (dot model) one of each color of disposable pens and plotter pen (pen model) time-lag fuse, two mounting brackets, one instruction manual and a quick reference manual.

**Insulation resistance:** Between terminals and ground: 20 MΩ or more (at 500 V DC)

**Dielectric strength:** Power terminals to ground: 1500 V AC (50/60 Hz) for one minute; Contact output terminals to ground: 1500 V AC (50/60 Hz) for one minute; Input terminals to ground: 1000 V AC (50/60 Hz) for one minute; Input terminals to input terminals: 1000 V AC (50/60 Hz) for one minute (Except RTD, as b terminals are interconnected); Remote control terminals to ground: 500 V DC for one minute

## ■ Safety standard

**Safety standard:** Complies with CSA1010.1, EN61010-1  
**EMC standard:** Complies with EN55011 Group 1 Class A  
 Complies with EN50082-2: 1995

## ■ NORMAL OPERATING CONDITIONS

**Power voltage:** 90 to 132 V, 180 to 250 V AC  
**Power-supply frequency:** 50 Hz ± 2%, 60 Hz ± 2%  
**Ambient temperature:** 0 to 50°C  
**Ambient humidity:** 20 to 80% RH (at 5 to 40°C)  
**Mounting:** Up to 30 backward from vertical  
 Horizontal viewed from the front

## ■ REFERENCE PERFORMANCE

### Measurement and recording accuracy

(Performance in reference operating conditions: 23 ± 2°C, 55 ± 10% RH; Power voltage ranges: 90 to 132 V, 180 to 250 V AC; Power-supply frequency: Within 50/60 Hz ± 1% after warm-up time of 30 minutes or more and in conditions such as little vibration which do not affect operation.)

Input type	RANGE	Measurement (digital printout)		Recording (analog)
		Measurement accuracy	Maximum resolution	Recording accuracy
DC voltage	20 mV	±(0.2% of rdg + 3digits)	10 μV	Measurement accuracy ± (0.3% of recording span)
	200 mV	±(0.2% of rdg + 2digits)	100 μV	
	2V	±(0.1% of rdg + 2digits)	1 mV	
	6V	±(0.3% of rdg + 2digits)	1 mV	
	20V	±(0.3% of rdg + 2digits)	10 mV	
Thermocouple (TC) Does not include reference junction compensation accuracy	Type	Measurement (digital printout)		Recording (analog)
		Measurement accuracy	Maximum resolution	Recording accuracy
	R	±(0.15% of rdg + 1°C) Except R,S: 0 to 100°C ± 3.7°C 100 to 300°C ± 1.5°C B: 400 to 600°C ± 2°C No guarantee under 400°C	0.1°C	Measurement accuracy ± (0.3% of recording span)
	S			
	B			
	K	±(0.15% of rdg + 0.7°C) Except at -200 to -100°C, ±(0.15% or rdg + 1°C)		
	E	±(0.15% of rdg + 0.5°C)	0.1°C	
	J	±(0.15% of rdg + 0.5°C) -200 to -100°C, ±(0.15% of rdg + 0.7°C)	0.1°C	
	T			
	N			
	W	±(0.15% of rdg + 1°C)	0.1°C	
	L	±(0.15% of rdg + 0.5°C) -200 to -100°C, ±(0.15% of rdg + 0.7°C)	0.1°C	
	U			
PR20-40	0 to 450°C: Not specified 450 to 750°C ±(0.9% of rdg + 3.2°C) 750 to 1100°C ±(0.9% of rdg + 1.3°C) 1100 to 1900°C ±(0.9% of rdg + 0.4°C)	0.1°C		
Platinel	±(0.25% of rdg + 2.3°C)			
Resistance temperature detector (RTD)	JPt100	±(0.15% of rdg + 0.3°C)	0.1°C	
	Pt100			
	Pt50	±(0.3% of rdg + 0.6°C)		
	Cu110 (A11)	±(0.4% of rdg + 1.0°C)		
	Cu25	±(0.3% of rdg + 0.8°C)		

Note: Recording span: 100 mm (μRS1000), 180 mm (μRS1800)

## Measurement accuracy at scaling:

Measurement accuracy at scaling (digits) = measurement accuracy (digits) × (scaling span (digits)/ Measurement span (digits)) + 2 digits (rounded off after the decimal point)

**Dead band (pen model):** Less than 0.2% of span

**Maximum recording resolution (dot printing model):**

Less than 0.1 mm

**Reference junction compensation accuracy:**

Type R, S, B, W: ±1°C

Type K, J, E, T, N, L, U: ±0.5°C

**Maximum input voltage:** 2 V DC or lower and TC ranges: ±10 V DC (continuous) 6 & 20 V DC ranges: ±30 V DC (continuous)

**Input resistance:** 10 MΩ or more (TC and 20, 200 mV, 2 V ranges)

Approximately 1 MΩ (6 and 20 V ranges)

**External input resistance:** DC V, TC input ..... 2 kΩ or less

RTD input ..... 10 Ω or less/wire (to be equal for three wires)

**Input bias current:** 10 nA or less (approximately 100 nA on a TC input if burnout detection selected)

**Maximum common mode voltage:** 250 V AC rms (50/60 Hz)

**Interference between channels:** 120 dB (external input resistance: 500Ω, when input to other channel is 30 V.)

**Common mode rejection ratio:** 120 dB (50/60 Hz ± 0.1%, 500Ω imbalance, between negative terminal and ground)

**Normal mode rejection ratio:** 40 dB (50/60 Hz ± 0.1%)

## STANDARD FEATURES TO EACH MODEL

Item	Details	μRS1000		μRS1800	
		Pen model	Dot-printing model	Pen model	Dot-printing model
Input	Number of inputs	1 to 4	6	1 to 4	6, 12, 18, 24
	Scan cycle time	125 ms	2.5s/6 points	125 ms	2.5s/6 points, 5s/12 points, 10s/18 & 24 points
Recording & printout	Effective recording span	100 mm		180 mm	
	90% step response	1 s or less		1.5 s or less	
	Print cycle time	Continuous printing for each channel	10 s/6 points (max.)	Continuous printing for each channel	10 s/6 points 15 s/12 points 20 s/18 points 30 s/24 points (max.)
	Chart	Z-fold paper (total length, 16 m)		Z-fold paper (total length, 20 m)	
	Recording colors	1st pen (Red) 2nd pen (Green) 3rd pen (Blue) 4th pen (Violet) Plotter (Purple)	No. 1 (Purple) No. 2 (Red) No. 3 (Green) No. 4 (Blue) No. 5 (Brown) No. 6 (Black)	1st pen (Red) 2nd pen (Green) 3rd pen (Blue) 4th pen (Violet) Plotter (Purple)	No. 1, 7, 13, 19 (Purple) No. 2, 8, 14, 20 (Red) No. 3, 9, 15, 21 (Green) No. 4, 10, 16, 22 (Blue) No. 5, 11, 17, 23 (Brown) No. 6, 12, 18, 24 (Black)
Dimensions & weight	External dimensions	144(W) × 144(H) × 220(D)mm		288(W) × 288(H) × 220(D)mm	
	Weight (approximate)	1 pen - 3.1 kg 4 pens - 3.7 kg	3.4 kg	1 pen - 8.7 kg 4 pens - 9.2 kg	6 points - 8.9 kg 24 points - 9.4 kg
Power consumption	At 100 V AC (approximate)	19 VA (4 pens) (max. 70 VA)	14 VA (max. 50 V A)	23 VA (4 pens) (max. 70 VA)	14 VA (max. 70 VA)

## OPTIONAL FEATURES

### Alarm relay contact output (/A1, /A2, /A3, /A4, /A5)

- Relay contact rating: 250 V DC/0.1 A (resistive load); 250 V AC (50/60 Hz)/3 A
- Output format: NO-C-NC (Excitation method OR output)

\* /A4, /A5 μRS1800 only

### Remote control (/R1)

Enables the following signal control through contact inputs from the rear of recorders.

- |                         |                 |
|-------------------------|-----------------|
|                         | Type of signals |
| • Recording start/stop  | Level           |
| • Chart speed change    | Level           |
| • Manual printout start | Trigger         |

### RS-422A interface (/C3)

Provides control and setting by host computer and outputs data to host through communications.

- Synchronizing format: Start-stop asynchronous transmission
- Specifications: Conforms to EIA RS-422A standards
- Communication system: 4-wire half duplex multidrop connection (1:N(N=1 to 16))
- Communication rate: 75, 150, 300, 600, 1200, 2400, 4800, 9600 bps
- Data length: 7 or 8 bits
- Stop bit: 1 or 2 bits
- Parity: Odd, even or none
- Communication distance: 500 m
- Communication mode: ASCII mode for input and output control and setting  
ASCII or Binary mode to output measured values

\* Address, communication rate, data length, stop bit and parity are set from the front pane key.

### FAIL/chart-end detection/output (/F1)

Upon CPU failure or when the chart paper reaches its end, outputs relay transfer contacts from the terminal block at back.

The chart-end status is also displayed on the front panel.

- Relay contact rating: 250 V DC, 0.1A (resistive load); 250 V AC 50/60 Hz, 3A

### Clamped input terminals (/H2)

Provides clamped input terminals instead of screw input terminals.

### Non-glare glass door (/H3)

Provides non-glare glass window in the front door.

### Pen offset compensation (/D1)

Eliminates the offset-in-time phase between pens.

### Thermocouple burnout protection - upscale (/B1)

### Thermocouple burnout protection - downscale (/B2)

Open-circuiting of input causes indication to drive upscale (/B1) or downscale (/B2).

- 2 kΩ max.; normal, 10 MΩ or more; detected as open circuit.
- Detecting current: approx. 100 nA

### Temperature unit change (/D2)

Using "°F" as temperature unit

### 24 V DC power supply (/P1)

- Rated power voltage: 24 V DC
- Usable power voltage: 21.6 to 26.4 V DC
- Maximum power consumption: 50 V AC (approx.)

### Digital display (/H8)

Provides digital display

## STANDARD ACCESSORIES & SPARES

Item	Part Number		Order Qty
	μRS1000	μRS1800	
Chart paper (1 chart/unit)	B9565AW	B9573AN	10 unit
6-color ribbon (1 pc/unit)	B9901AX	B9906JA	1 unit
Disposable felt pens (3 pc/unit)	Red (1st pen)	B9930BP	1 unit
	Green (2nd pen)	B9930BQ	1 unit
	Blue (3rd pen)	B9930BR	1 unit
	Violet (4th pen)	B9930BS	1 unit
Plotter pen (3 pc/unit)	Purple	B9902AR	1 unit
Panel mounting hardware (1 pc/unit)		B9900CW	2 unit
Lubricating oil (for dot model only, 1 pc/unit)		B9901AZ	1 unit

## AVAILABLE MODELS

## MODEL AND SUFFIX CODES

Model	Suffix codes	Description																																																																																																																																																				
436501 436502 436503 436504 436506	_____ _____ _____ _____ _____	μRS1000 1-pen recorder μRS1000 2-pen recorder μRS1000 3-pen recorder μRS1000 4-pen recorder μRS1000 6-dot recorder																																																																																																																																																				
437501 437502 437503 437504 437506 437512 437518 437524	_____ _____ _____ _____ _____ _____ _____ _____	μRS1800 1-pen recorder μRS1800 2-pen recorder μRS1800 3-pen recorder μRS1800 4-pen recorder μRS1800 6-dot recorder μRS1800 12-dot recorder μRS1800 18-dot recorder μRS1800 24-dot recorder																																																																																																																																																				
Input of 1st pen (for pen model)	-00 to -44	<table border="1"> <thead> <tr> <th colspan="6">Range codes</th> </tr> <tr> <th>Input type</th> <th>Range code</th> <th colspan="2">Measurement range</th> <th>Range code</th> <th>Measurement range</th> </tr> </thead> <tbody> <tr> <td rowspan="3">DC V</td> <td>00</td> <td colspan="2">-20.00 to 20.00 mV</td> <td>03</td> <td>-6.000 to 6.000 V</td> </tr> <tr> <td>01</td> <td colspan="2">-200.0 to 200.0 mV</td> <td>04</td> <td>-20.00 to 20.00 V</td> </tr> <tr> <td>02</td> <td colspan="2">-2.000 to 2.000 V</td> <td></td> <td></td> </tr> <tr> <td rowspan="3">DC V (linear scaling)</td> <td>30</td> <td colspan="2">-20.00 to 20.00 mV</td> <td>33</td> <td>-6.000 to 6.000 V</td> </tr> <tr> <td>31</td> <td colspan="2">-200.0 to 200.0 mV</td> <td>34</td> <td>-20.00 to 20.00 V</td> </tr> <tr> <td>32</td> <td colspan="2">-2.000 to 2.000 V</td> <td></td> <td></td> </tr> <tr> <td rowspan="3">DC V (square root scaling)</td> <td>40</td> <td colspan="2">-20.00 to 20.00 mV</td> <td>43</td> <td>-6.000 to 6.000 V</td> </tr> <tr> <td>41</td> <td colspan="2">-200.0 to 200.0 mV</td> <td>44</td> <td>-20.00 to 20.00 V</td> </tr> <tr> <td>42</td> <td colspan="2">-2.000 to 2.000 V</td> <td></td> <td></td> </tr> <tr> <td rowspan="6">TC</td> <td rowspan="6">-00 to -44</td> <td>10</td> <td>R 0 to 1760°C 32 to 3200°F</td> <td>16</td> <td>T -200 to 400°C -328 to 752°F</td> </tr> <tr> <td>11</td> <td>S 0 to 1760°C 32 to 3200°F</td> <td>17</td> <td>N 0 to 1300°C 32 to 2372°F</td> </tr> <tr> <td>12</td> <td>B 0 to 1820°C 32 to 3308°F</td> <td>18</td> <td>W 0 to 2315°C 32 to 4199°F</td> </tr> <tr> <td>13</td> <td>K -200 to 1370°C -328 to 2498°F</td> <td>19</td> <td>L -200 to 900°C -328 to 1652°F</td> </tr> <tr> <td>14</td> <td>E -200 to 800°C -328 to 1472°F</td> <td>1A</td> <td>U -200 to 400°C -328 to 752°F</td> </tr> <tr> <td>15</td> <td>J -200 to 1100°C -328 to 2012°F</td> <td>1B</td> <td>PR20-40 0 to 1900°C 32 to 3452°F</td> </tr> <tr> <td></td> <td></td> <td>1C</td> <td>Platinel 0 to 1400°C 32 to 2552°F</td> </tr> <tr> <td rowspan="6">3rd pen input of 3- or 4-pen recorder (unnecessary to specify for dot-printing model)</td> <td rowspan="6">-00 to -44</td> <td>20</td> <td>JPt100 -200 to 550°C -328 to 1022°F</td> <td>25</td> <td>Cu10 (WEEED) -200 to 300°C -328 to 572°F</td> </tr> <tr> <td>21</td> <td>Pt100 -200 to 600°C -328 to 1112°F</td> <td>26</td> <td>Cu10 (BAILEY) -200 to 300°C -328 to 572°F</td> </tr> <tr> <td>22</td> <td>Pt50 -200 to 600°C -328 to 1112°F</td> <td>27</td> <td>Cu10 (*) -200 to 300°C -328 to 572°F</td> </tr> <tr> <td>23</td> <td>Cu10(GE) -200 to 300°C -328 to 572°F</td> <td>28</td> <td>Cu10 (**) -200 to 300°C -328 to 572°F</td> </tr> <tr> <td>24</td> <td>Cu10(L&amp;N) -200 to 300°C -328 to 572°F</td> <td>29</td> <td>Cu25 -200 to 300°C -328 to 572°F</td> </tr> <tr> <td>62</td> <td>Two measurement ranges for DC V</td> <td>82</td> <td>Two measurement ranges for DC V, TC, or RTD (EXCEPT CU10, 25)</td> </tr> <tr> <td rowspan="5">4th pen input of 4-pen recorder (unnecessary to specify for dot-printing recorder)</td> <td rowspan="5">-00 to -44</td> <td>63</td> <td>Three measurement ranges for DC V</td> <td>83</td> <td>Three measurement ranges for DC V, TC, or RTD (EXCEPT CU10, 25)</td> </tr> <tr> <td>64</td> <td>Four measurement ranges for DC V</td> <td>84</td> <td>Four measurement ranges for DC V, TC, or RTD (EXCEPT CU10, 25)</td> </tr> <tr> <td>72</td> <td>Two measurement ranges for DC V or TC</td> <td>92</td> <td>2 measurement ranges for DCV, TC &amp; RTD (Cu10, 25)</td> </tr> <tr> <td>73</td> <td>Three measurement ranges for DC V or TC</td> <td>93</td> <td>3 measurement ranges for DCV, TC &amp; RTD (Cu10, 25)</td> </tr> <tr> <td>74</td> <td>Four measurement ranges for DC V or TC</td> <td>94</td> <td>4 measurement ranges for DCV, TC &amp; RTD (Cu10, 25)</td> </tr> <tr> <td rowspan="2">Optional feature</td> <td rowspan="2">/ <input type="checkbox"/></td> <td colspan="4">                     JPt100: JIS C 1604-1981, JIS C 1606-1989                      Pt100 : JIS C 1604-1989, JIS C 1606-1989, DIN IEC 751, IEC751                      Pt50 : JIS C 1604-1981, JIS C 1606-1986                 </td> </tr> <tr> <td colspan="4">                     *1: α = 0.00392 @ 20°C                      *2: α = 0.00393 @ 20°C                 </td> </tr> </tbody> </table>	Range codes						Input type	Range code	Measurement range		Range code	Measurement range	DC V	00	-20.00 to 20.00 mV		03	-6.000 to 6.000 V	01	-200.0 to 200.0 mV		04	-20.00 to 20.00 V	02	-2.000 to 2.000 V				DC V (linear scaling)	30	-20.00 to 20.00 mV		33	-6.000 to 6.000 V	31	-200.0 to 200.0 mV		34	-20.00 to 20.00 V	32	-2.000 to 2.000 V				DC V (square root scaling)	40	-20.00 to 20.00 mV		43	-6.000 to 6.000 V	41	-200.0 to 200.0 mV		44	-20.00 to 20.00 V	42	-2.000 to 2.000 V				TC	-00 to -44	10	R 0 to 1760°C 32 to 3200°F	16	T -200 to 400°C -328 to 752°F	11	S 0 to 1760°C 32 to 3200°F	17	N 0 to 1300°C 32 to 2372°F	12	B 0 to 1820°C 32 to 3308°F	18	W 0 to 2315°C 32 to 4199°F	13	K -200 to 1370°C -328 to 2498°F	19	L -200 to 900°C -328 to 1652°F	14	E -200 to 800°C -328 to 1472°F	1A	U -200 to 400°C -328 to 752°F	15	J -200 to 1100°C -328 to 2012°F	1B	PR20-40 0 to 1900°C 32 to 3452°F			1C	Platinel 0 to 1400°C 32 to 2552°F	3rd pen input of 3- or 4-pen recorder (unnecessary to specify for dot-printing model)	-00 to -44	20	JPt100 -200 to 550°C -328 to 1022°F	25	Cu10 (WEEED) -200 to 300°C -328 to 572°F	21	Pt100 -200 to 600°C -328 to 1112°F	26	Cu10 (BAILEY) -200 to 300°C -328 to 572°F	22	Pt50 -200 to 600°C -328 to 1112°F	27	Cu10 (*) -200 to 300°C -328 to 572°F	23	Cu10(GE) -200 to 300°C -328 to 572°F	28	Cu10 (**) -200 to 300°C -328 to 572°F	24	Cu10(L&N) -200 to 300°C -328 to 572°F	29	Cu25 -200 to 300°C -328 to 572°F	62	Two measurement ranges for DC V	82	Two measurement ranges for DC V, TC, or RTD (EXCEPT CU10, 25)	4th pen input of 4-pen recorder (unnecessary to specify for dot-printing recorder)	-00 to -44	63	Three measurement ranges for DC V	83	Three measurement ranges for DC V, TC, or RTD (EXCEPT CU10, 25)	64	Four measurement ranges for DC V	84	Four measurement ranges for DC V, TC, or RTD (EXCEPT CU10, 25)	72	Two measurement ranges for DC V or TC	92	2 measurement ranges for DCV, TC & RTD (Cu10, 25)	73	Three measurement ranges for DC V or TC	93	3 measurement ranges for DCV, TC & RTD (Cu10, 25)	74	Four measurement ranges for DC V or TC	94	4 measurement ranges for DCV, TC & RTD (Cu10, 25)	Optional feature	/ <input type="checkbox"/>	JPt100: JIS C 1604-1981, JIS C 1606-1989 Pt100 : JIS C 1604-1989, JIS C 1606-1989, DIN IEC 751, IEC751 Pt50 : JIS C 1604-1981, JIS C 1606-1986				*1: α = 0.00392 @ 20°C *2: α = 0.00393 @ 20°C			
		Range codes																																																																																																																																																				
Input type	Range code	Measurement range		Range code	Measurement range																																																																																																																																																	
DC V	00	-20.00 to 20.00 mV		03	-6.000 to 6.000 V																																																																																																																																																	
	01	-200.0 to 200.0 mV		04	-20.00 to 20.00 V																																																																																																																																																	
	02	-2.000 to 2.000 V																																																																																																																																																				
DC V (linear scaling)	30	-20.00 to 20.00 mV		33	-6.000 to 6.000 V																																																																																																																																																	
	31	-200.0 to 200.0 mV		34	-20.00 to 20.00 V																																																																																																																																																	
	32	-2.000 to 2.000 V																																																																																																																																																				
DC V (square root scaling)	40	-20.00 to 20.00 mV		43	-6.000 to 6.000 V																																																																																																																																																	
	41	-200.0 to 200.0 mV		44	-20.00 to 20.00 V																																																																																																																																																	
	42	-2.000 to 2.000 V																																																																																																																																																				
TC	-00 to -44	10	R 0 to 1760°C 32 to 3200°F	16	T -200 to 400°C -328 to 752°F																																																																																																																																																	
		11	S 0 to 1760°C 32 to 3200°F	17	N 0 to 1300°C 32 to 2372°F																																																																																																																																																	
		12	B 0 to 1820°C 32 to 3308°F	18	W 0 to 2315°C 32 to 4199°F																																																																																																																																																	
		13	K -200 to 1370°C -328 to 2498°F	19	L -200 to 900°C -328 to 1652°F																																																																																																																																																	
		14	E -200 to 800°C -328 to 1472°F	1A	U -200 to 400°C -328 to 752°F																																																																																																																																																	
		15	J -200 to 1100°C -328 to 2012°F	1B	PR20-40 0 to 1900°C 32 to 3452°F																																																																																																																																																	
		1C	Platinel 0 to 1400°C 32 to 2552°F																																																																																																																																																			
3rd pen input of 3- or 4-pen recorder (unnecessary to specify for dot-printing model)	-00 to -44	20	JPt100 -200 to 550°C -328 to 1022°F	25	Cu10 (WEEED) -200 to 300°C -328 to 572°F																																																																																																																																																	
		21	Pt100 -200 to 600°C -328 to 1112°F	26	Cu10 (BAILEY) -200 to 300°C -328 to 572°F																																																																																																																																																	
		22	Pt50 -200 to 600°C -328 to 1112°F	27	Cu10 (*) -200 to 300°C -328 to 572°F																																																																																																																																																	
		23	Cu10(GE) -200 to 300°C -328 to 572°F	28	Cu10 (**) -200 to 300°C -328 to 572°F																																																																																																																																																	
		24	Cu10(L&N) -200 to 300°C -328 to 572°F	29	Cu25 -200 to 300°C -328 to 572°F																																																																																																																																																	
		62	Two measurement ranges for DC V	82	Two measurement ranges for DC V, TC, or RTD (EXCEPT CU10, 25)																																																																																																																																																	
4th pen input of 4-pen recorder (unnecessary to specify for dot-printing recorder)	-00 to -44	63	Three measurement ranges for DC V	83	Three measurement ranges for DC V, TC, or RTD (EXCEPT CU10, 25)																																																																																																																																																	
		64	Four measurement ranges for DC V	84	Four measurement ranges for DC V, TC, or RTD (EXCEPT CU10, 25)																																																																																																																																																	
		72	Two measurement ranges for DC V or TC	92	2 measurement ranges for DCV, TC & RTD (Cu10, 25)																																																																																																																																																	
		73	Three measurement ranges for DC V or TC	93	3 measurement ranges for DCV, TC & RTD (Cu10, 25)																																																																																																																																																	
		74	Four measurement ranges for DC V or TC	94	4 measurement ranges for DCV, TC & RTD (Cu10, 25)																																																																																																																																																	
Optional feature	/ <input type="checkbox"/>	JPt100: JIS C 1604-1981, JIS C 1606-1989 Pt100 : JIS C 1604-1989, JIS C 1606-1989, DIN IEC 751, IEC751 Pt50 : JIS C 1604-1981, JIS C 1606-1986																																																																																																																																																				
		*1: α = 0.00392 @ 20°C *2: α = 0.00393 @ 20°C																																																																																																																																																				

## OPTIONAL SPECIFICATIONS

Option	Option Code	Description
Alarm output relay; 2 points	/A1	Relay contact rating: 250 V AC and 3 A, or 250 V DC and 0.1 A <b>Note:</b> Two or more cannot be specified together. <b>Note:</b> /A4 and /A5 can be specified only for μRS1800.
Alarm output relay; 4 points	/A2	
Alarm output relay; 6 points	/A3	
Alarm output relay; 12 points	/A4	
Alarm output relay; 24 points	/A5	
TC burnout protection (upscale)	/B1	Open-circuiting of input causes indication to drive upscale. Open-circuiting of input causes indication to drive downscale.
TC burnout protection (downscale)	/B2	
RS-422A communication interface	/C3	A host computer can control and set parameters or receive the data.
Pen offset compensation	/D1	Eliminates the offset of time-phase (phase difference) between the pen traces in 2-, 3-, and 4-pen recorders.
Temperature unit change	/D2	Using °F as temperature unit
FAIL/chart-end detection/output	/F1	Detecting failure in the CPU or when the chart paper reaches its end, displays the detection and outputs transfer contacts.
Clamped input terminals	/H2	Uses clamps for input terminals.
Non-glare glass door	/H3	Provides specially treated non-glare glass for front door.
Digital display	/H8	Provides digital display
24 V DC power supply	/P1	24 V DC power supply
Remote control	/R1	Enables the following control functions: <ul style="list-style-type: none"> <li>• recording start/stop,</li> <li>• chart speed change</li> <li>• manual printout start.</li> </ul>
Scale plate	/SC12 /SC13 /SC22 /SC23 /SC33	Single scale and double marking for dot-printing recorder Single scale and triple marking for dot-printing recorder Double scale and double marking for dot-printing recorder Double scale and triple marking for dot-printing recorder Triple scale and triple marking for dot-printing recorder <b>Note:</b> No option code need be specified for a pen model or single scale with single marking for dot-printing recorder. <b>Note:</b> Option code is to be selected as per the required specification. (Refer to TI 4D6B1-01E.)

## ORDERING INFORMATION

1. Model and suffix codes
2. Option codes
3. Recording span in each channel
4. When 6□, 7□, 8□ or 9□ is specified for the range code of a dot recorder:
  - for 62, 72, 82 or 94- specify the two range codes, the recording spans and corresponding channel numbers,
  - for 63, 73, 83 or 94- specify the three range codes, the recording spans and corresponding channel numbers,
  - for 64, 74, 84 or 94- specify the four range codes, the recording spans and corresponding channel numbers
5. When a scaling range (range code: 30 to 34 and 40 to 44) is required, specify the scaling value (numeric value only) and unit.  
In case the scaling range is required within the specified range code, 6□, 7□, 8□, 9□ also specify the scaling value(s) and unit(s) in the same way.
6. Scale and unit of the scale plate.

**[Example]** For Model μRS1000 (1-pen recorder):

436501 - 16 / B1 / C3 / R1

Model                      Optional specifications  
   Input of 1st pen (Type T)

## Possible combinations of optional features

μRS1000	/A1	/A2	/A3
Any model without /F1	○	○	○
with /F1	○	○	×

μRS1800	/A1	/A2	/A3	/A4	/A5
Pen model without /F1	○	○	○	×	×
with /F1	○	○	○	×	×
6-dot model without /F1	○	○	○	○	×
with /F1	○	○	○	×	×
12-, 18, and w/o /F1	○	○	○	○	○
24-dot, model with /F1	○	○	○	○	×

## OPTIONAL ACCESSORIES

Name	Model code	Specification
Shunt resistance (For screw input terminal block)	<b>415920</b>	250 Ω ±0.1%
	<b>415921</b>	100 Ω ±0.1%
	<b>415922</b>	10 Ω ±0.1%
Shunt resistance (For clamped input terminal block)	<b>438920</b>	250 Ω ±0.1%
	<b>438921</b>	100 Ω ±0.1%
	<b>438922</b>	10 Ω ±0.1%

**DIMENSIONS**

μRS1000

Unit: mm  
(approx. inch)

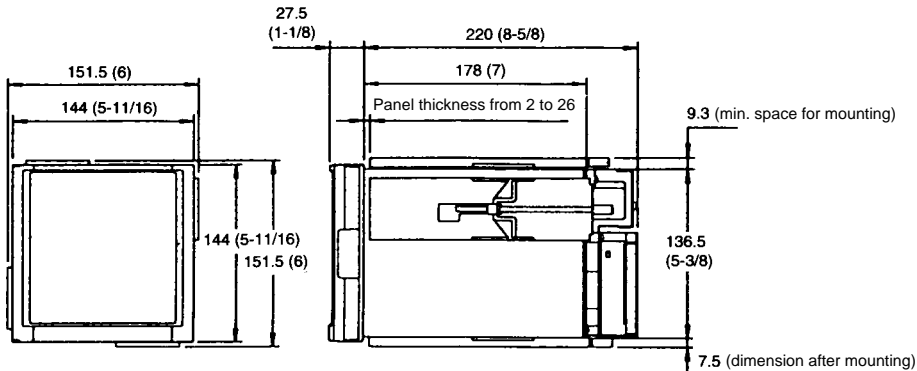

**Single Unit Mounting**

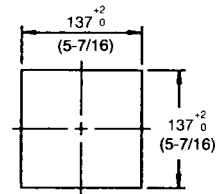

(Panel Cutout)

**Note:** The mounting hardware is attached on both sides or at the top and bottom (2 places) for panel mounting. See the general specification sheet (GS 4D6B1-E) for the panel cutout for side-by-side or top-and-bottom mounting.

μRS1800

Unit: mm  
(approx. inch)

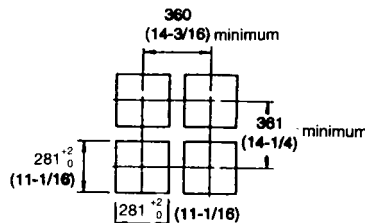
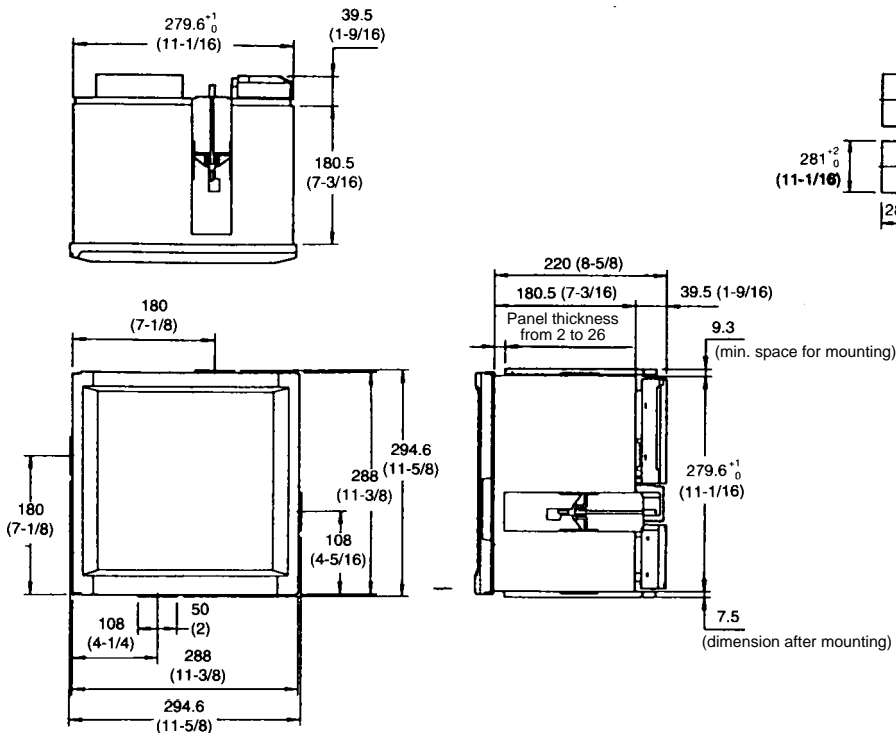

(Panel Cutout)

**Note:** The mounting hardware is attached on both sides or at the top and bottom (2 places) for panel mounting.