

General Specifications

Model DC402G Converter for Dual Cell Conductivity or Resistivity



Flexibility, reliability and low maintenance are among the benefits provided by the EXA DC402G conductivity analyser. Designed to meet the exacting requirements of measuring dual cell conductivity and resistivity in the modern industrial environment, it contains many features to ensure the best precision whatever the application. Differential, ratio, deviation, % passage or % rejection can be indicated and/or transmitted. This 4-wire converter is housed in a robust IP65 field mountable case. Two mA outputs, four relays, digital communication and a clear LCD make the DC402G a truly comprehensive package. The DC402G features PI control on the auxiliary mA output and the pulse proportional relay outputs, thus avoiding the need for a separate controller. The famous EXA sensor diagnostics are also present in the DC402G. Self-tuning of the excitation frequency and measuring pulses ensure optimum accuracy. The polarisation check gives on line indication of sensor fouling and early warning that maintenance is needed. A wide variety of temperature compensation possibilities (NaCl according to IEC 746-3, manual TC, preprogrammed matrices and a freely programmable 5x5 matrix), provides a high-accuracy measurement with minimum effort.







FEATURES

- Differential, ratio or calculated outputs
- Universal conductivity/resistivity, software switchable
- On-line sensor checking
- Self-tuning measuring signal
- Matrix temperature compensation for pure water applications
- Four fully configurable SPDT contact outputs
- Two fully configurable mA outputs
- Built-in PI controller
- Easy to use EXA control panel
- USP 23 monitoring

APPLICATIONS

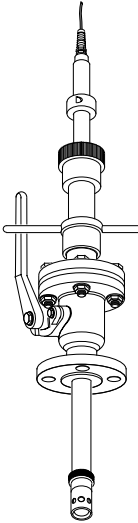
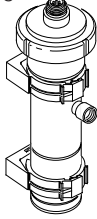
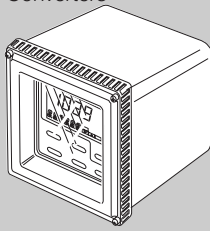
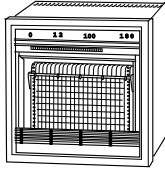
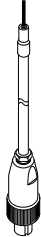
- Monitoring performances of cation exchange columns (Ratio output)
- Leak detection of heat exchanges (Deviation output)
- Monitoring performance of reverse osmosis columns (Percent rejection output)
- Controlling flowrate of wash water (Differential output)
- Controlling blow-down of cooling towers (Ratio output)
- Redundancy for accurate analysis (Deviation output)
- Monitoring very high purity systems (Differential Resistivity)
- Pharmaceutical water monitoring (USP23)

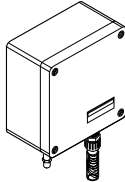
SYSTEM CONFIGURATION

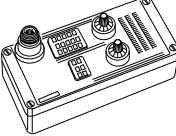
<p>Sensors</p> 	<p>Fittings</p> 	<p>Fittings</p> 	<p>Converters</p> 	<p>Receivers</p> 
<p>Cables</p> 		<p>Connecting Equipment</p> 		<p>Tester</p> 

WHAT IS DUAL CONDUCTIVITY?

Dual cell conductivity is a precise, comparative measurement. The EXA DC402G receives inputs from two conductivity cells located at different points in the process and compares them according to one of five programmed user-selectable formulae

- Ratio (a/b)
- Differential or linear difference (a-b)
- Percent passage (b/a x 100)
- Percent rejection $\{(a-b)/a \times 100\}$
- Deviation $\{(b/a) a \times 100\}$

The output signal corresponds directly to the formulas. The EXA DC402G also displays the absolute value of each cell on a second display line, as desired by the user. The unit displays all values in conductivity units ($\mu\text{S}/\text{cm}$ or mS/cm) percentage (%), or resistivity ($\text{M}\Omega\cdot\text{cm}$).

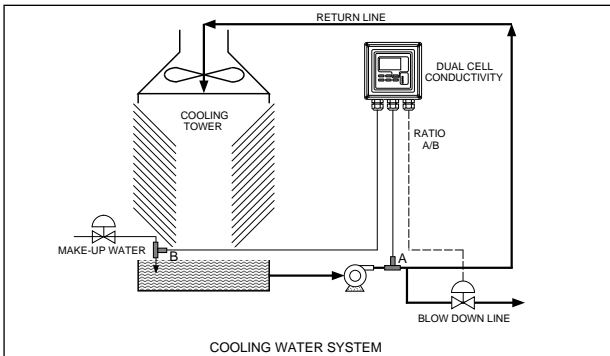

Fig. 1. Ratio output controls blow-down of cooling tower based on concentration factor.

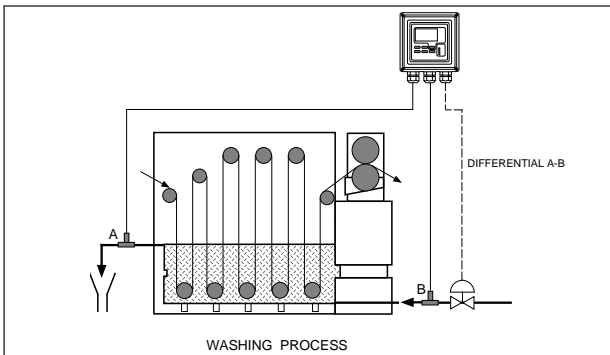

Fig. 2. Differential output water flow to optimise washing efficiency.

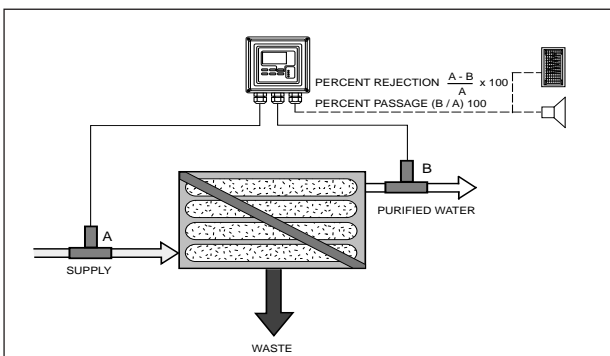

Fig. 3. %-rejection or %-passage output indicates the efficiency of the Reverse Osmosis system.

PROCESS TEMPERATURE COMPENSATION

Automatic, according to NaCl tables (IEC-746-3 tables)

From the factory, the DC402G is configured for non-linear temperature compensation according to NaCl tables which will give accuracy in most measurements. In this case no site adjustments are required. For applications where NaCl compensation is not sufficient, other compensation possibilities are presented below.

Matrix

The DC402G is equipped with a matrix type algorithm (conductivity as a function of concentration and temperature) for accurate temperature compensation in various applications.

For pure water applications the following choices can be made:

- HCl (cation) compensation (0 - 80 °C)
 - Ammonia compensation (0 - 80 °C)
 - Morpholine compensation (0 - 80 °C)
- For higher conductivity ranges the choices are:
- HCl (1 - 5 %, 0 - 60 °C)
 - NaOH (1 - 5 %, 0 - 100 °C)
 - 25 points (5 x 5) user programmable matrix.

This matrix can easily be programmed from the service mode by entering 5 temperature points, followed by conductivity values for each concentration at the 5 temperatures.

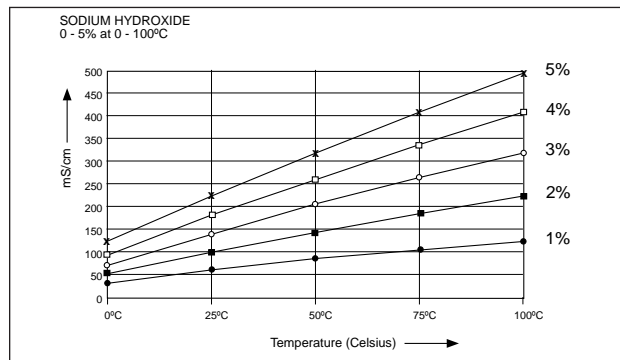

Fig. 4. Example of matrix temperature compensation

Manual Temperature coefficient

It is also possible to have a linear compensation with programmable coefficient. Both outputs can have their own independent TC.

At start-up a known temperature coefficient may be entered from the service mode, or the TC can be adjusted by calibration, using actual process solutions. The freely programmable reference temperature also contributes to a high accuracy measurement.

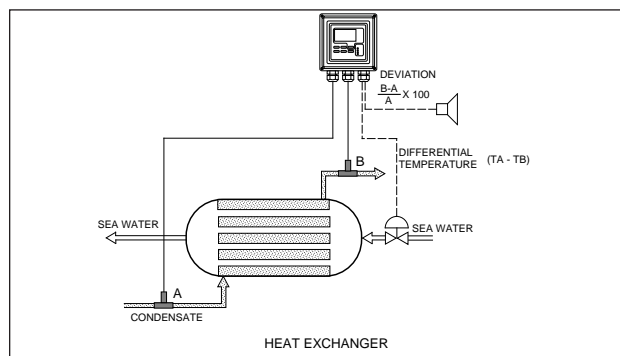

Fig. 5. Deviation output alarms directly after leakage in the heat exchanger.

SIGNAL CONDITIONING FOR HIGHEST ACCURACY

Two conductivity cells with cell constants between 0.01 to 50 m^{-1} can be connected to the EXA DC402G. For temperature compensation the instrument accepts inputs from Ni100 * Pt100, Pt1000/8K55/PB36, sensors. The self tuning preamplifier measures 0.1 $\mu\text{S}\cdot\text{cm}$ up to 25 $\text{mS}\cdot\text{cm}$ by measuring frequency optimisation and pulse sampling position.

C= cell constant in cm^{-1} .

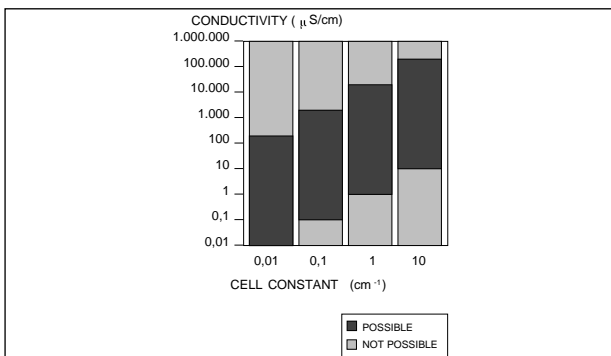

Fig. 6. Measuring range as function of the cell constant

SIGNAL MONITORING AND ALARM

The EXA DC402G features a built-in check for electrode fouling and polarisation, which activates a contact "FAIL" signal and error message for operators. There is also an option to program an alarm on the 4-20 mA analog signal. The "FAIL" contact is used as a fail-safe alarm that also indicates power-down.

THREE PROCESS CONTACT OUTPUTS

The EXA DC402G permits three user-programmable output contacts. As a default, 2 functions are defined as high and low alarm.

The switch function of the contacts can freely be set for:

- a calculated value (ratio, differential, %)
- a conductivity value (from cell A or B)
- a temperature value (from sensor A or B)

Some examples of user-selectable output functions:

- process alarm as a high or low trip function;
- proportional duty cycle control with adjustable cycle period and control assigned by a proportional range and setpoint;
- proportional frequency control with number of pulses and control assigned by the proportional range and setpoint.

TWO INDEPENDENT CURRENT OUTPUTS

Two 0-20 or 4-20 mA outputs for registration, indication or control functions.

The user can select from:

- the calculated comparative value
- the linearised conductivity/resistivity value (from cell A or B)
- the measured temperature value (from sensor A or B)
- the temperature difference between cell A and B/ sensors A and B.
- Pi control on value from cell A or B.

The EXA DC402G features 4 additional output functions:

- a "HOLD" function that maintains process values until return of a normal operation
- a "BURN OUT" function that gives a HIGH or LOW output at fail status (22mA or 3.5 mA)
- a programmable I/O output function that allows user to linearise the output(s) when used as a concentration analysers
- output damping to stabilise the control or monitoring function.

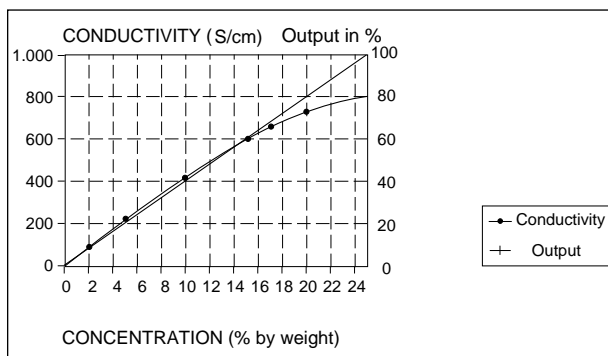

Fig.7. Output linear to concentration

CUSTOM DESIGN DISPLAY

The main display shows the primary function (calculated value cell A) in 31/2 digits 13 mm (1/2") LCD.

On a second line a variety of data can be displayed (in 6 alpha numeric digits) including:

- measured conductivity value of cell A or B
- measured temperature of sensor A or B
- calibrated cell constant for cell A or B
- mA value of current output 1 or 2
- temperature compensation function for sensor A or B
- description of comparative function
- differential temperature (if additional comparative function is selected for current output 1 or 2).

USP23 MONITORING

DC402G monitors water quality according to the USP23 directive (United States Pharmacopeia). Both compensated and uncompensated conductivity values can be read from the display, as can the solution temperature. Alarms can be set to indicate that the signal is nearing the USP23 limit, and there is a trip alarm to indicate that the limit is exceeded. USP23 determines a level of uncompensated conductivity for each temperature. The water must be below this level to be acceptable. This curve is pre-programmed into DC402G and is used in the setpoint calculations for the alarms and trip.

GENERAL SPECIFICATIONS

A. Input specifications

: Two inputs, each 2-electrode measurement with square wave excitation, using cell constants from 0.008 to 50.0 cm⁻¹, with up to 60 metres (200ft) connection cable

B. Detection method

: Frequency, read-pulse position and reference voltage are dynamically optimized.

C. Input ranges

Minimum : 0.1 μ S x C at process temperature (underrange 0.000 μ S/cm).
 Maximum : 25 mS x C at process temperature (overrange 30 mS x C).
- Resistivity : 0.00 k Ω - 999 M Ω /C at 25 °C (77 °F) reference temperature.
 Minimum : 0.04 k Ω /C at process temperature (underrange 0.001 k Ω x cm).
 Maximum : 10 M Ω /C at process temperature (overrange 999 M Ω x cm).
- Temperature
 Pt1000 : -20 to +250 °C (0 - 500 °F)
 Pt100 and Ni100 : -20 to +200 °C (0 - 400 °F)
 8K55 NTC : -10 to +120 °C (10 - 250 °F)
 PB36 NTC : -20 to +120 °C (0 - 250 °F)

D. Span

Conductivity/Resistivity

- Minimum span : 0.010 μ S/cm; 0.001 k Ω x cm up to 90% zero suppression.
 - Maximum span : 1500 mS/cm; 999 M Ω x cm

Ratio (cell1/cell2)

- Minimum span : 00.0
 - Maximum span : 19.99

Difference (cell1-cell2)

- Minimum span : 0.010 μ S/cm
 - Maximum span : 400mS/cm

% Passage (100x[cell2/cell1])

- Minimum span : 00.0
 - Maximum span : 199.9

% Rejection (100x[(cell1-cell2)/cell1])

- Minimum span : 0.1
 - Maximum span : 400

% Deviation (100x[(cell2-cell1)/cell1])

- Minimum span : 0.1
 - Maximum span : 400

Temperature

- Minimum span : 25 °C (50 °F)
 - Maximum span : 250°C (500 °F)

Difference Temperature

- Minimum span : 25 °C(50 °F)
 - Maximum span : 250 °C (500 °F)

E. Transmission Signals

: Two isolated outputs of 0/4-20 mA DC with common negative.
 Maximum load 600 Ω .
 Auxiliary output can be chosen from conductivity, linearised conductivity resistivity, temperature, differential temperature calculated value or PI control of conductivity/resistivity.
 Burn up (22 mA) or Burn down (0/3.5 mA) to signal failure.

F. Temperature compensation

: Automatic, for temperature ranges mentioned under C (inputs).

- Reference temperature

: programmable from 0 to 100 °C or 30 - 210 °F (default 25 °C).

G. Compensation algorithm

: According IEC 746-3 NaCl tables (default).
 Two independent user programmable temperature coefficients, from -9.99% to 9.99% per °C (°F) by adjustment or calibration.

- Matrix compensation

: With conductivity function of concentration and temperature. Choice out of 5 preprogrammed matrices and a 25-points user-programmable matrix.

H. Display

: Custom liquid crystal display, with a main display of 3 1/2 digits 12.5 mm high. Message display of 6 alphanumeric characters, 7 mm high.
 Warning flags and units (mS/cm, k Ω .cm, μ S/cm and M Ω .cm) as appropriate.

I. Contact Outputs

- General

: Four (4) SPDT relay contacts with LED indicators. For S1, S2, and S3, the LED is on when relay is powered.
 NOTE: For S4 (FAIL) LED lights when power is removed (Fail safe).
 Contact outputs configurable for hysteresis and delay time.

- Switch capacity

: Maximum values 100 VA, 250 VAC, 5 Amps.
 Maximum values 50 Watts, 250 VDC, 5 Amps.

- Status

: High/low process alarms, selected from conductivity, resistivity and temperature. Contact output is also available to signal "Hold active"

- Control function

: On / Off
 PI pulsed - Proportional duty cycle control with integral term.
 PI frequency - Proportional frequency control with integral term.
 (PI control on Conductivity/Resistivity only) In addition FAIL alarm for system and diagnostic errors on S4.

- J. Power Supply** : - 230 VAC $\pm 15\%$, 50/60 Hz, maximum consumption 10 VA.
 - 115 VAC $\pm 15\%$, 50/60 Hz, maximum consumption 10 VA.
 - 100 VAC $\pm 15\%$, 50/60 Hz, maximum consumption 10 VA.
 - 24 VDC -20% / +30%, maximum consumption 10 Watts.

- K Shipping Details** : Package size w x h x d
 290 x 225 x 170 mm.
 11.5 x 8.9 x 6.7 in.
 Packed weight approx. 2.5 kg (5lb).

OPERATING SPECIFICATIONS

- A. Performance : Conductivity**
 - Linearity : $\leq 0.5\% \pm 0.02$ mA
 - Repeatability : $\leq 0.5\% \pm 0.02$ mA
 - Accuracy : $\leq 0.5\% \pm 0.02$ mA
Performance : Resistivity(>6M Ω)
 - Linearity : ≤ 0.02 M $\Omega \pm 0.02$ mA
 - Repeatability : ≤ 0.01 M $\Omega \pm 0.02$ mA
 - Accuracy : ≤ 0.03 M $\Omega \pm 0.02$ mA
Performance : Resistivity (other ranges, up to 6 M Ω x cm)
 - Linearity : $\leq 0.5\% \pm 0.02$ mA
 - Repeatability : $\leq 0.5\% \pm 0.02$ mA
 - Accuracy : $\leq 0.5\% \pm 0.02$ mA
Performance : Temperature with Pt100 Ω , Ni100 Ω and PB36 NTC
 - Linearity : ≤ 0.3 $^{\circ}\text{C} \pm 0.02$ mA
 - Repeatability : ≤ 0.3 $^{\circ}\text{C} \pm 0.02$ mA
 - Accuracy : ≤ 0.3 $^{\circ}\text{C} \pm 0.02$ mA
Performance : Temperature with PT100 Ω and 8k55 Ω
 - Linearity : ≤ 0.4 $^{\circ}\text{C} \pm 0.02$ mA
 - Repeatability : ≤ 0.4 $^{\circ}\text{C} \pm 0.02$ mA
 - Accuracy : ≤ 0.4 $^{\circ}\text{C} \pm 0.02$ mA
Performance : Temperature compensation
 - NaCl table : $\leq 1\%$
 - Matrix : $\leq 3\%$
 - Ambient influence : $\leq 0.05\%$ / $^{\circ}\text{C}$
 - Step response : 90% (< 2 decades) in ≤ 9 seconds

- B. Ambient operating temperature**
 : -10 to +55 oC (-10 to 130 $^{\circ}\text{F}$) Excursions to -30 to 70oC will not damage the instrument.

- C. Storage temperature**
 : -30 to +70 oC (-20 to 160 $^{\circ}\text{F}$)

- D. Humidity** : 10 to 90% RH non-condensing

- E. Housing** : Cast aluminium case with chemically resistant coating, cover with flexible polycarbonate window. Case color is off-white and cover is moss green. Cable entry is via six 1/2" polyamide glands. Cable terminals are provided for up to 2.5 mm² finished wires. Weather resistant to IP65 and NEMA 4X standards. Pipe wall or panel mounting, using optional hardware.

- F. Data protection** : EEPROM for configuration and logbook, and lithium battery for clock.

- G. Watchdog timer** : Checks microprocessor

- H. Automatic safeguard**
 : Return fo measuring mode when no keystroke is made for 10 min.

- I. Power interruption**
 : Less than 50 milliseconds no effect.
 More than 50 milliseconds reset to measurement.

- J. Operation protection**
 : 3-digit programmable password.

- K. Regulatory Compliance**
 - **EMC** : meets council directive 89/336/EEC
 - **Emmission** : meets EN 55022 Class A
 - **Immunity** : meets EN 50082-2
 - **Low voltage** : Meets council directive 73/23/EEC
 - **Installation** : Designed for installation conforming to IEC 1010-1, Category II.

MODEL AND SUFFIX CODES

Model	Suffix code	Option code	Description
DC402G			Conductivity/resistivity transmitter
	-E		Always E
Supply voltage	-1		115 Volts 50/60 Hz
	-2		230 Volts 50/60 Hz
	-4		24 Volts DC
	-5		100 Volts 50/60 Hz
Instruction manual	-E		English language*
Options		/PIN	Advanced feature access code
		/U	Pipe and wall mounting hardware
		/PM	Panel mountin hardware
		/Q	Quality certificate
		/SCT	Stainless steel tag

* For other languages contact local sales office

CONTROL AND ALARM FUNCTIONS

Control output (mA) : PI control on the 2nd mA output.
 The 2nd mA output can be configured to give a P/I (proportional and integral) control output.

- Adjustable parameters : Setpoint, proportional range and integral time.

Process alarm : The contact will be switched when the process value reaches a limit. This can either be a high or low limit.

- Adjustable parameters : Setpoint for the process value Hysteresis of the switching action Delay time of the relay (0 to 200 s)

PI duty cycle control : The contact is used to control the time a solenoid dosing valve is opened. The proportional control is achieved by opening and closing the solenoid valve and varying the ratio of on and off time (on, off).

- Adjustable parameters : Setpoint, proportional range and integral time. Total period of the pulse period (5 to 100 s)

Fault alarm : Contact S4 by default set to function as an alarm, indicating that the EXA has found a fault in the measuring loop. If the self diagnostics of the EXA indicate a fault or error, the FAIL contact will be switched. In most cases this will be caused by a malfunction of the measuring loop. The FAIL contact is also closed when the power is removed. The "FAIL" contact may also be configured as a fourth process alarm.

PI pulse frequency control : The contact is used to control a pulse-driven dosing pump. The frequency of pulses regulates the pump speed.

- Adjustable parameters : Setpoint, proportional range & integral time. Maximum pulse frequency (50 to 120/min.)

CABLES AND TERMINALS

The DC402G is equipped with terminals suitable for the connection of finished cables in the size range of 0.13 to 2.5 mm² (26 to 14 AWG).

The glands will form a tight seal on cables of outside diameter in the range 7 to 12 mm (9/32" to 15/32").

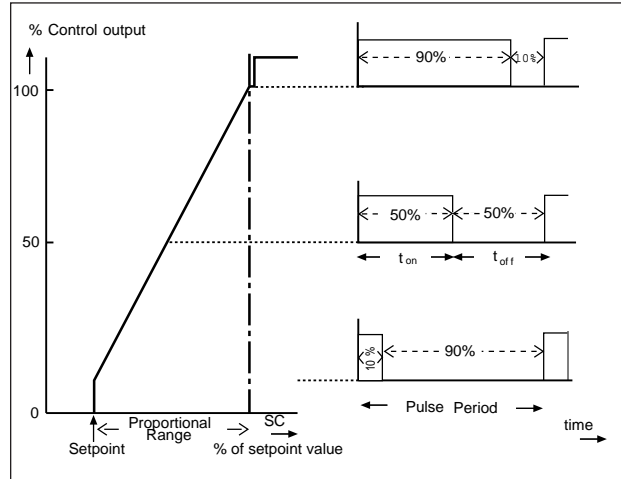

Fig. 8. Duty cycle control

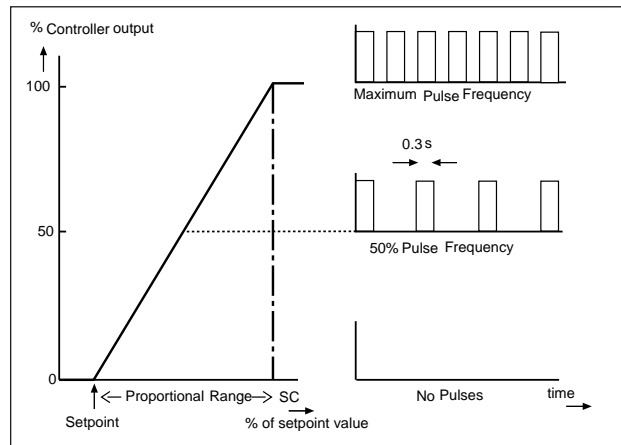

Fig. 9. Pulse frequency control

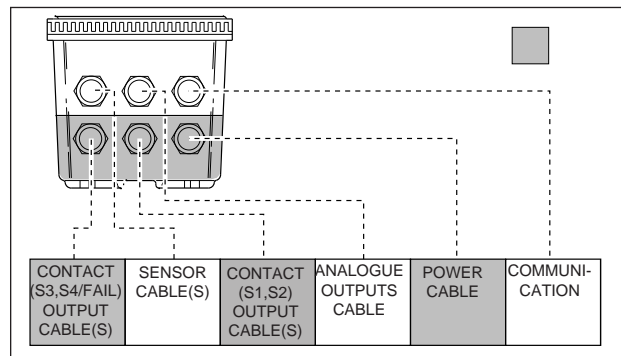

Fig. 10. Glands to be used for cabling

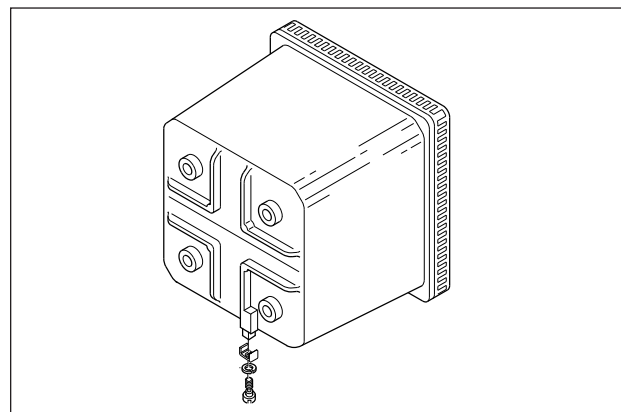
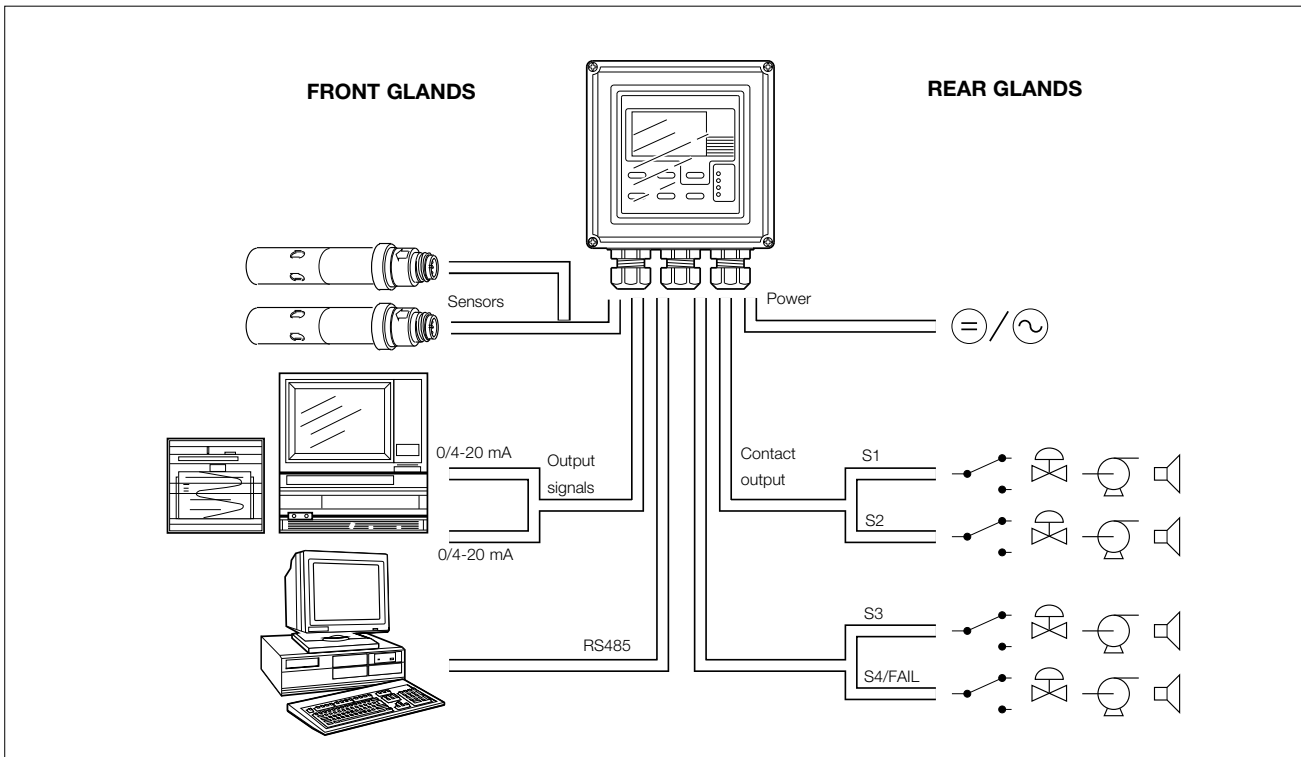
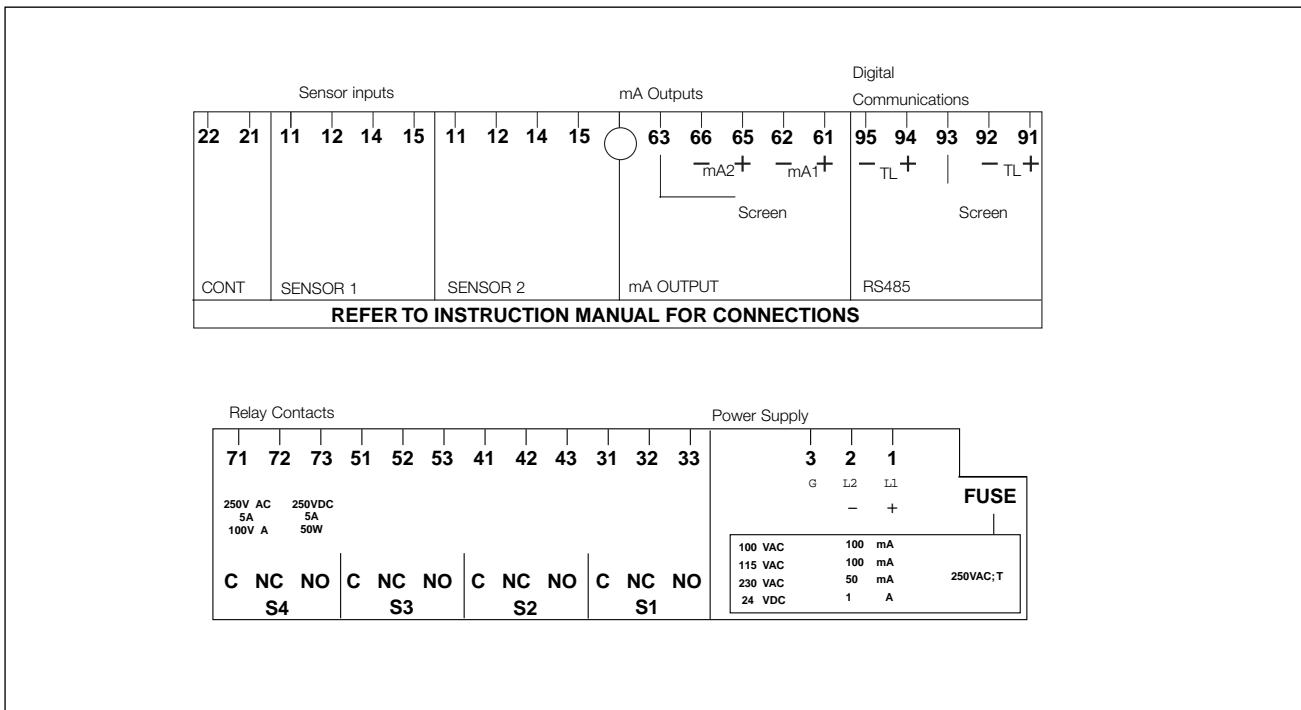

Fig. 11 Grounding

SYSTEM CONFIGURATION



INPUT AND OUTPUT CONNECTIONS



DIMENSIONS AND MOUNTING

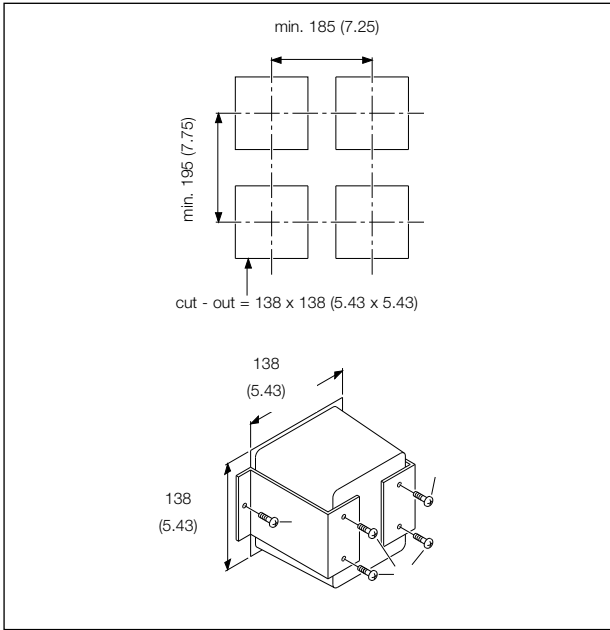

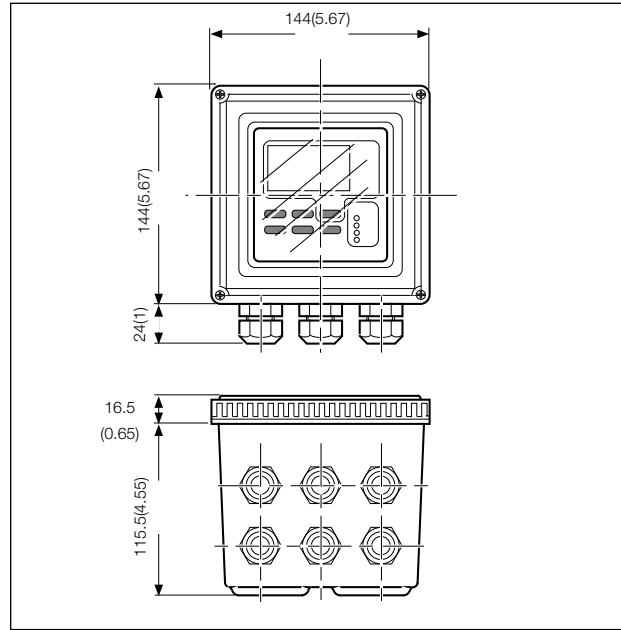

Panel cut-out, spacing and mounting

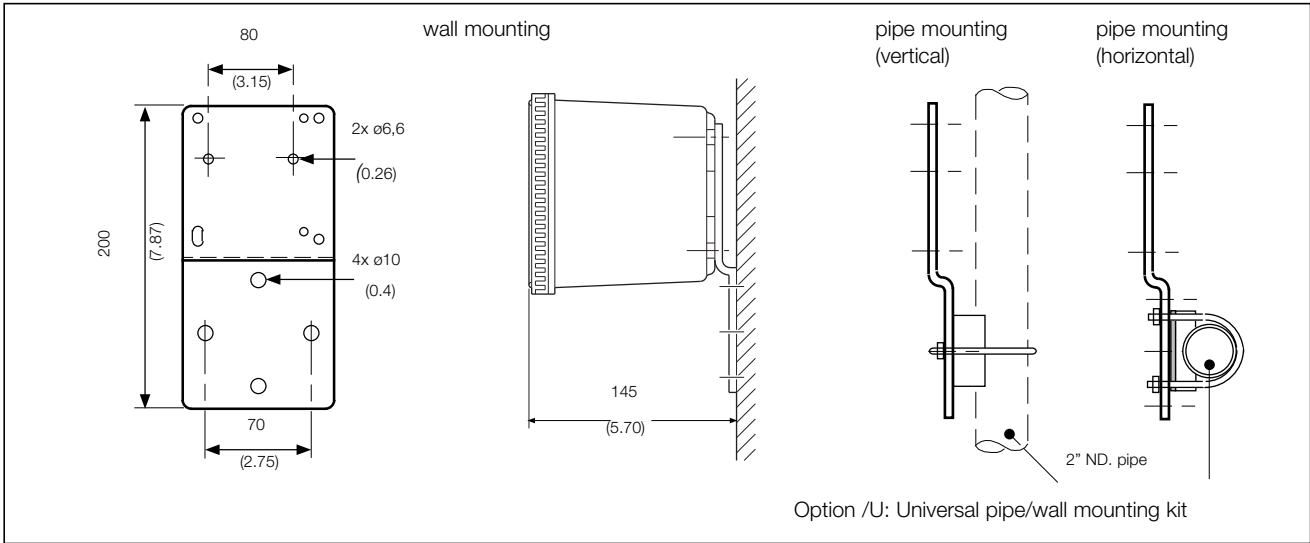

Dimensions



Universal pipe/wall mounting

<p>YOKOGAWA </p> <p>EUROPEAN HEADQUARTERS Yokogawa Europe B.V. Vanadiumweg 11, 3812 PX AMERSFOORT The Netherlands Tel. +31-33-4641 611 Fax +31-33-4641 610 E-mail: info@yokogawa.nl</p> <p>THE NETHERLANDS Yokogawa Nederland B.V. Computerweg 1, 3606 AV MAARSSSEN Tel. +31-346-59 12 11 Fax +31-346-56 61 96</p>		<p>AUSTRIA Yokogawa Austria Ges.m.b.H. Franzensbrückenstrasse 26 A-1021 WIEN Tel. +43-1-216 50 43 Fax +43-1-216 50 43 33</p>	<p>GERMANY Yokogawa Deutschland GmbH Berliner Strasse 101-103 D-40880 RATINGEN Tel. +49-2102-4983 0 Fax +49-2102-4983 22</p>	<p>ITALY Yokogawa Italia S.r.l. Vicolo D. Pantaleoni, 4 20161 MILANO Tel. +39-2-66 24 11 Fax +39-2-645 57 02</p>	<p>AUSTRALIA Yokogawa Australia Pty Ltd. Private mail bag 24 Centre Court D3 25-27 Paul Street North NORTH RYDE, N.S.W. 2113 Tel. +61-2-805 0699 Fax +61-2-888 1844</p>	<p>UNITED STATES OF AMERICA Yokogawa Industrial Automation 4 Dart Road NEWNAN, GA 30265-1040 Tel. +1-770-254 0400 Fax +1-770-251 6427</p> <p>ISO 9001  CERTIFICATED FIRM</p>
		<p>BELGIUM Yokogawa Belgium N.V./S.A. Minervastraat 16 1930 ZAVENTEM Tel. +32-2-719 55 11 Fax +32-2-725 34 99</p>	<p>SPAIN Yokogawa España S.A. O/Francisco Remiro, N°2, Edif. H 28028 MADRID Tel. +34-1-724 20 80 Fax +34-1-355 31 40</p>	<p>SINGAPORE Yokogawa Engineering Asia Pte. Ltd. 11, Tampines Street 92 SINGAPORE, 528872 Tel. +65-783 9537 Fax +65-786 2606</p>	<p>JAPAN Yokogawa Electric Corporation 2-9-32, Nakacho, Musashino-shi TOKYO, 180 Tel. +81-422 52 5617 Fax +81-422 52 0622</p>	
<p>FRANCE Yokogawa Contrôle Bailey S.A. Vélizy Valley 18-20 Rue Grange Dame Rose 78140 VELIZY VILLACOUBLAY Tel. +33-1-39 26 10 00 Fax +33-1-39 26 10 30</p>		<p>UNITED KINGDOM Yokogawa United Kingdom Ltd. Stuart Road, Manor Park, RUNCORN Cheshire WA7 1TR Tel. +44-1-928 597100 Fax +44-1-928 597101</p>		<p>SOUTH AFRICA Yokogawa South Africa (Pty) Ltd. 67 Port Road, Robertsham Southdale 2135, JOHANNESBURG Tel. +27-11-680-5420 Fax +27-11-680-2922</p>	<p>CENTRAL/EAST REGION Via Yokogawa Austria: Czechia, Slovakia, Hungary, Poland, Croatia, Slovenia, Jugoslavia, Bulgaria, Romania, Macedonia, Bosnia & Herzegovina</p> <p>Distributors in: Denmark, Finland, Greece, Norway, Portugal, Russian Federation, Sweden, Switzerland, South Africa and Turkey.</p>	