

General Specifications

Model SC402G Converter for Conductivity or Resistivity



Flexibility, reliability and low maintenance are among the benefits provided by the EXA SC402G conductivity analyser. Designed to meet the exacting requirements of measuring conductivity and resistivity in the modern industrial environment, it contains many features to ensure the best precision whatever the application.

This 4-wire converter is housed in a robust IP65 field mountable case. Two mA outputs, four relays, digital communication and a clear LCD make the SC402G a truly comprehensive package.

The SC402G features PI control on both the auxiliary mA output and the pulse proportional relay outputs, thus avoiding the need for a separate controller.

The famous EXA sensor diagnostics are now expanded with a logbook facility in combination with the RS485 two wire communication software option. This can be used to record events like cell constant changes and diagnostic messages.





A wide variety of temperature compensation possibilities (NaCl according to IEC 746-3, manual TC, preprogrammed matrices and a free programmable 5x5 matrix), provides a high-accuracy measurement with minimum effort.

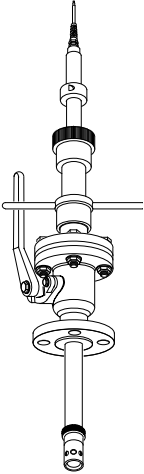
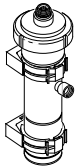
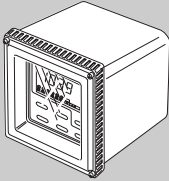
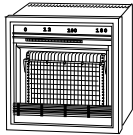

FEATURES

- Universal conductivity/resistivity, software switchable
- On-line sensor checking
- RS485 communications interface
- Event logbook in software
- Matrix temperature compensation for pure water applications
- Four fully configurable SPDT contact outputs
- Two fully configurable mA outputs
- Built-in PI controller
- Easy to use EXA control panel
- Pharmaceutical water monitoring (USP23)

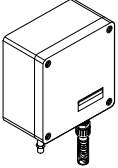
SYSTEM CONFIGURATION

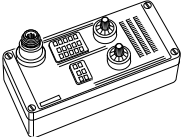
| | | | | |
|--|---|---|--|--|
| <p>Sensors</p>  | <p>Fittings</p>  | <p>Fittings</p>  | <p>Converters</p>  | <p>Receivers</p>  |
| <p>Cables</p>  |  | <p>Connecting Equipment</p>  |  | <p>Tester</p>  |

ACCURATE CONDUCTIVITY MEASUREMENT

Electrode selection

In order to make precise conductivity measurements, there are a number of prerequisites. Most important is the selection of suitable sensors. Special attention should be paid to the choice of the sensors to ensure compatibility with both the chemical composition and the specific conductivity of the fluid to be measured. The installation of the sensor is also very important for a correct measurement. Other Yokogawa specification sheets cover the choice of sensors and holders, and any Yokogawa sales office can provide expert advice.

NOTE:

In the case of applications using highly conductive fluids, inductive conductivity measurement should be considered as an alternative because of lower maintenance requirements.

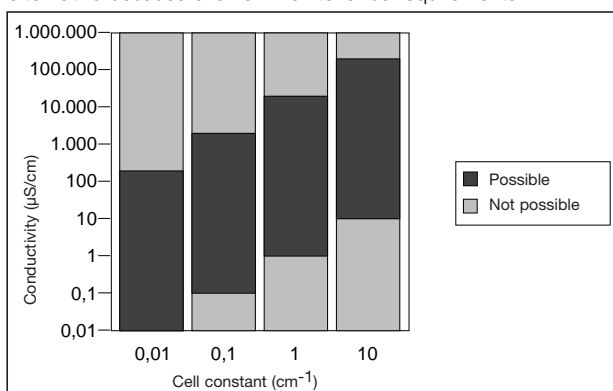

Measuring range as function of the cell constant

NOTE:

With 2-electrode systems some polarisation may decrease the measured conductivity value at higher concentrations.

Fault diagnosis

The measurement is continuously checked for faults, giving warning of breakage, non-immersion, fouling and cable problems. These faults are signalled by the FAIL contact output and can be signalled to the control room by a current of 22 mA, or 0/3.5 mA. The fault is also signalled by a special marker field in the display, a LED on the front and an error code in the message display.

Pin code

Communication, logbook and PI control functions are available via the optional (/PIN) access code. When this option is specified, Yokogawa provides a coded access number to switch on the advanced functions.

Converter design

The system is designed to minimize the effect of external influences.

Signal processing ensures that only changes in conductivity cause changes in the output. That is why EXA instruments offer a wide range of temperature compensation possibilities.

USP23 Monitoring

SC402G monitors water quality according to the USP23 directive (United States Pharmacopoeia). Both compensated and uncompensated conductivity values can be read from the display, as can the solution temperature. Alarms can be set to indicate that the signal is nearing the USP23 limit, and there is a trip alarm to indicate that the limit is exceeded. USP23 determines a level of uncompensated conductivity for each temperature. The water must be below this level to be acceptable. This curve is preprogrammed into SC402G and is used in the setpoint calculations for the alarms and trip.

PROCESS TEMPERATURE COMPENSATION

Automatic, according to NaCl tables (IEC-746-3 tables)

From the factory, the SC402G is configured for non-linear temperature compensation according NaCl tables which will give accuracy in most measurements. In this case no site adjustments are required. For applications where NaCl compensation is not sufficient, other compensation possibilities are presented below.

Matrix

The SC402G is equipped with a matrix type algorithm (conductivity as a function of concentration and temperature) for accurate temperature compensation in various applications.

For pure water applications the following choices can be made:

- HCl (cation) compensation (0 - 80 °C)
- Ammonia compensation (0 - 80 °C)
- Morpholine compensation (0 - 80 °C)

For higher conductivity ranges the choices are:

- HCl (1 - 5 %, 0 - 60 °C)
- NaOH (1 - 5 %, 0 - 100 °C)
- 25 points (5 x 5) user programmable matrix.

This matrix can easily be programmed from the service mode by entering 5 temperature points, followed by conductivity values for each concentration at the 5 temperatures.

Example of matrix temperature compensation

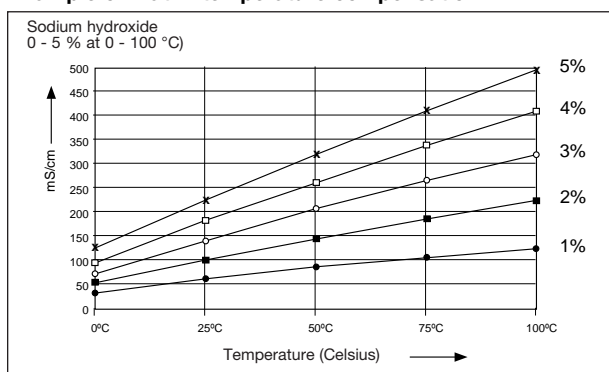

Manual Temperature coefficient

It is also possible to have a linear compensation with programmable coefficient. Both outputs can have their own independent TC.

At start-up a known temperature coefficient may be entered from the service mode, or the TC can be adjusted by calibration, using actual process solutions. The freely programmable reference temperature also contributes to a high accuracy measurement.

SIGNAL PROCESSING

With the correct sensor configuration it is possible to measure either conductivity or resistivity.

The EXA SC402G is equipped with RS485 communication ability. Communication lines are isolated from the input and output signals. Communication speed is selectable from 1200, 2400, 4800, 9600 baud. The format is selectable for even, odd, and no parity. The SC402G can be accessed over this 2-way communication link.

Logbook

In combination with 2-way communication, there is a logbook feature. This is a software record of events, calibrations, alarms and the like. A total of approximately 100 events can be stored. New additions are made by overwriting the oldest entry, once 100 entries have been exceeded. Access is via the RS485 link, and Yokogawa's PC402 software package.

OUTPUT SIGNAL

The standard SC402G features two 0-20 mA or 4-20 mA current outputs available for registration, and indication or control functions.

The user selectable application can represent:

- the measured conductivity value
- the measured resistivity value
- the measured temperature value

In addition the following output functions are available:

- a "HOLD" function that maintains process value or a fixed value until return to normal operation
- a "BURN" function that gives a high or low output at fail status
- a programmable output function that allows the user to linearise the output(s) when used as a concentration analyser.

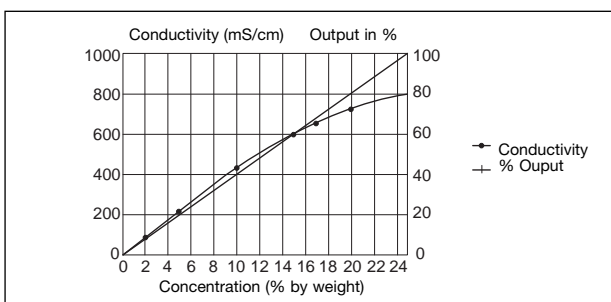

Linearisation of output

Example: 0-25% Sulfuric acid

| Code Output | mA 4-20 | Conc. | Example % H ₂ SO ₄ | Cond. | Example mS/cm |
|-------------|---------|-------|--|-------|---------------|
| 0 | 4 | | 0 | | 0 |
| 5 | 4.8 | | 1.25 | | 60 |
| 10 | 5.6 | | 2.5 | | 113 |
| 15 | 6.4 | | 3.75 | | 180 |
| 20 | 7.2 | | 5 | | 211 |
| 25 | 8 | | 6.25 | | 290 |
| 30 | 8.8 | | 7.5 | | 335 |
| 35 | 9.6 | | 8.75 | | 383 |
| 40 | 10.4 | | 10 | | 424 |
| 45 | 11.2 | | 11.25 | | 466 |
| 50 | 12 | | 12.5 | | 515 |
| 55 | 12.8 | | 13.75 | | 555 |
| 60 | 13.6 | | 15 | | 590 |
| 65 | 14.4 | | 16.25 | | 625 |
| 70 | 15.2 | | 17.5 | | 655 |
| 75 | 16 | | 18.75 | | 685 |
| 80 | 16.8 | | 20 | | 718 |
| 85 | 17.6 | | 21.25 | | 735 |
| 90 | 18.4 | | 22.5 | | 755 |
| 95 | 19.2 | | 23.75 | | 775 |
| 100 | 20.0 | | 25 | | 791 |

THREE LEVEL OPERATION

The EXA SC402G converter uses a 3-level operating system to take full advantage of the microprocessor while retaining the traditional simplicity of analog converters. Advanced functions are separated from conventional operation to avoid confusion. They can be activated as required for each individual application.

1. The normal maintenance functions are accessible through the flexible window by pushing the keys underneath.
2. Functions required to commission the instrument are hidden to discourage unauthorized tampering. The front cover is removed to reveal the commissioning menu and the hidden access key (marked *).
3. Specialised functions can be adjusted via the SERVICE menu. In this case access is by using "service codes."

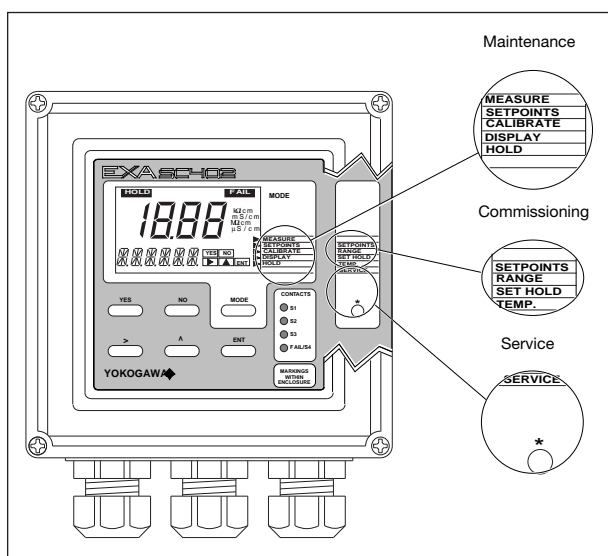

Three level operation

MAINTENANCE level

- Use : Normal operation and checking
 How : Simple operation by dialog through the closed front cover
 Example : Setpoints setting

COMMISSIONING level

- Use : For normal commissioning
 How : Removal of the front cover reveals the access key and second menu
 Example : Output range setting

SERVICE level

- Use : Only for specialised functions
 How : Through special service code entries
 Example : Selecting process compensation

With this 3-level user-friendly approach, the instrument can be operated by anyone. Commissioning is straight-forward and needs no calibration equipment compared to analog instruments. Special functions available via access codes are invisible during normal operation. All three levels can be separately protected against unauthorised access by a password system using a three digit code.

GENERAL SPECIFICATIONS

- A. Input specifications** : Two or four electrodes measurement with square wave excitation, using max. 60 m (200 ft) cable (WU40/WF10) and cell constants from 0.008 to 50.0 cm⁻¹
- B. Detection method** : Frequency, read-pulse position and reference voltage are dynamically optimized.
- C. Input ranges**
- Conductivity : 0.000 μS/cm to 1999 mS/cm at 25 °C (77 °F) reference temperature.
 - Minimum : 0.1 μS x C at process temperature (underrange 0.000 μS/cm).
 - Maximum : 500 mS x C at process temperature (overrange 550 mS x C).
 - Resistivity : 0.000 kΩ - 999 MΩ/C at 25 °C (77 °F) reference temperature.
 - Minimum : 0.002 kΩ/C at process temperature (underrange 0.000 kΩ x cm).
 - Maximum : 1 MΩ/C at process temperature (overrange 999 MΩ x cm).
 - Temperature
 - Pt1000 : -20 to +250 °C (0 - 500 °F)
 - Pt100 and Ni100 : -20 to +200 °C (0 - 400 °F)
 - 8K55 NTC : -10 to +120 °C (10 - 250 °F)
 - PB36 NTC : -20 to +120 °C (0 - 250 °F)
- D. Span**
- Conductivity : - min. 0.010 uS/cm, - max. 1999 mS/cm. (max 90% zero suppression)
 - Resistivity : - min. 0.001 kΩ x cm - max. 999 MΩ x cm. (max 90% zero suppression)
 - Temperature : Dependant on temp. sensor type:

| Sensor type | min. | max. |
|--------------------|---------------|-----------------|
| Pt1000 | 25 °C (50 °F) | 250 °C (500 °F) |
| Pt100, Ni100 | 25 °C (50 °F) | 200 °C (400 °F) |
| PB36 NTC, 8K55 NTC | 25 °C (50 °F) | 100 °C (200 °F) |

 The instrument is user programmable for linear or non-linear conductivity ranges.
- E. Transmission Signals**
- : Two isolated outputs of 0/4-20 mA DC with common negative. Maximum load 600 Ω. Auxiliary output can be chosen from conductivity, resistivity, temperature or PI control
 - Burn up (22 mA) or Burn down (0/3.5 mA) to signal failure.
- F. Temperature compensation**
- : Automatic, for temperature ranges mentioned under C (inputs).
 - Reference temp. : programmable from 0 to 100 °C or 30 - 210 °F (default 25 °C).
- G. Compensation algorithm**
- : According IEC 746-3 NaCl tables (default). Two independent user programmable temperature coefficients, from -9.99% to 9.99% per °C (°F) by adjustment or calibration.

- Matrix compensation: with conductivity function of concentration and temperature. Choice out of 5 preprogrammed matrixes and a 25-points user-programmable matrix.

H. Serial Communication

: Bi-directional according to the EIA-485 standard using HART-protocol and PC402 software.

I. Logbook

: Software record of important events and diagnostic data. Available through RS485.

J. Display

: Custom liquid crystal display, with a main display of 3½ digits 12.5 mm high. Message display of 6 alpha-numeric characters, 7 mm high. Warning flags and units (mS/cm, kΩ.cm, uS/cm and MΩ.cm) as appropriate.

K. Contact Outputs

- General : Four (4) SPDT relay contacts with LED indicators. For S1, S2, and S3, the LED is on when relay is powered. NOTE: For S4 (FAIL) LED lights when power is removed (Fail safe). Contact outputs configurable for hysteresis and delay time.
- Switch capacity : Maximum values 100 VA, 250 VAC, 5 Amps. Maximum values 50 Watts, 250 VDC, 5 Amps.
- Status : High/low process alarms, selected from conductivity, resistivity and temperature. Contact output is also available to signal "Hold active"
- Control function : On / Off
PI pulsed - Proportional duty cycle control with integral term.
PI frequency - Proportional frequency control with integral term. In addition FAIL alarm for system and diagnostic errors on S4

L. Contact Input

- : Remote range switching to 10 times the programmed range.
- Contact open : If impedance > 100 kΩ: Range 1
- Contact closed : If impedance < 10 Ω: Range 2 (10 x Range 1)

M. Power Supply

- 230 VAC ±15%, 50/60 Hz, maximum consumption 10 VA.
- 115 VAC ±15%, 50/60 Hz, maximum consumption 10 VA.
- 100 VAC ±15%, 50/60 Hz, maximum consumption 10 VA.
- 24 VDC -20% / +30%, maximum consumption 10 Watts.

N. Input isolation

: 1000 VDC

O. Shipping Details

: Package size w x h x d
290 x 225 x 170 mm.
11.5 x 8.9 x 6.7 in.
Packed weight approx. 2.5 kg (5lb).

OPERATING SPECIFICATIONS

- A. Performance**
- Linearity : $\leq 0.5\% \pm 0.02 \text{ mA}$
 - Repeatability : $\leq 0.5\% \pm 0.02 \text{ mA}$
 - Accuracy : $\leq 0.5\% \pm 0.02 \text{ mA}$
- Performance** : **Resistivity**
- Linearity : $\leq 0.02 \text{ M}\Omega \pm 0.02 \text{ mA}$
 - Repeatability : $\leq 0.01 \text{ M}\Omega \pm 0.02 \text{ mA}$
 - Accuracy : $\leq 0.03 \text{ M}\Omega \pm 0.02 \text{ mA}$
- Performance** : **Resistivity (other ranges, up to 5 M Ω x cm)**
- Linearity : $\leq 0.5\% \pm 0.02 \text{ mA}$
 - Repeatability : $\leq 0.5\% \pm 0.02 \text{ mA}$
 - Accuracy : $\leq 0.5\% \pm 0.02 \text{ mA}$
- Performance** : **Temperature with Pt1000 Ω , Ni100 Ω and PB36 NTC**
- Linearity : $\leq 0.3\text{ }^\circ\text{C} \pm 0.02 \text{ mA}$
 - Repeatability : $\leq 0.3\text{ }^\circ\text{C} \pm 0.02 \text{ mA}$
 - Accuracy : $\leq 0.3\text{ }^\circ\text{C} \pm 0.02 \text{ mA}$
- Performance** : **Temperature with PT100 Ω and 8k55 Ω**
- Linearity : $\leq 0.4\text{ }^\circ\text{C} \pm 0.02 \text{ mA}$
 - Repeatability : $\leq 0.4\text{ }^\circ\text{C} \pm 0.02 \text{ mA}$
 - Accuracy : $\leq 0.4\text{ }^\circ\text{C} \pm 0.02 \text{ mA}$
- Performance** : **Temperature compensation**
- NaCl table : $\leq 1\%$
 - Matrix : $\leq 3\%$
 - Ambient influence : $\leq 0.05\% / ^\circ\text{C}$
 - Step response : 90% (< 2 decades) in ≤ 3 seconds
- B. Ambient operating temperature**
- 10 to +55 $^\circ\text{C}$ (-10 to 130 $^\circ\text{F}$)
 - Excursions to -30 to +70 $^\circ\text{C}$ (10 to 160 $^\circ\text{F}$) will not damage the instrument
- C. Storage temperature**
- 30 to +70 $^\circ\text{C}$ (-20 to 160 $^\circ\text{F}$)
- D. Humidity**
- 10 to 90% RH non-condensing
- E. Housing**
- Cast aluminium case with chemically resistant coating, cover with flexible polycarbonate window. Case color is off-white and cover is moss green. Cable entry is via six 1/2" polyamide glands. Cable terminals are provided for up to 2.5 mm² finished wires. Weather resistant to IP65 and NEMA 4X standards. Pipe wall or panel mounting, using optional hardware.
- F. Data protection**
- EEPROM for configuration and logbook, and lithium battery for clock.
- G. Watchdog timer**
- Checks microprocessor
- H. Automatic safeguard**
- Return to measuring mode when no keystroke is made for 10 min.
- I. Power interruption**
- Less than 50 milliseconds no effect. More than 50 milliseconds reset to measurement.
- J. Operation protection**
- 3-digit programmable password.

K. Regulatory compliance

- EMC : meets council directive 89/336/EEC
- Emission : meets EN 55022 Class A
- Immunity : meets EN 50082-2
- Low voltage : meets council directive 73/23/EEC
- Installation : Designed for installation conforming to IEC 1010-1, Category II.

MODEL AND SUFFIX CODES

| Model | Suffix code | Option code | Description |
|--------------------|-------------|-------------|--------------------------------------|
| SC402G | | | Conductivity/resistivity transmitter |
| | -E | | Always E |
| Supply voltage | -1 | | 115 Volts 50/60 Hz |
| | -2 | | 230 Volts 50/60 Hz |
| | -4 | | 24 Volts DC |
| | -5 | | 100 Volts 50/60 Hz |
| Instruction manual | -E | | English language* |
| Options | /PIN | | Advanced feature access code |
| | /U | | Pipe and wall mounting hardware |
| | /PM | | Panel mounting hardware |
| | /Q | | Quality certificate |
| | /SCT | | Stainless steel tag |

* For other languages contact local sales office

CONTROL AND ALARM FUNCTIONS

Control output (mA) : PI control on the 2nd mA output. The 2nd mA output can be configured to give a P/I (proportional and integral) control output. The setpoint, proportional band and integral time are each fully programmable.

- Adjustable parameters : Setpoint, proportional range and integral time.

Process alarm : The contact will be switched when the process value reaches a limit. This can either be a high or low limit.

- Adjustable parameters : Setpoint for the process value
Hysteresis of the switching action
Delay time of the relay (0 to 200 s)

PI duty cycle control : The contact is used to control the time a solenoid dosing valve is opened. The proportional control is achieved by opening and closing the solenoid valve and varying the ratio of on and off time (t_{on} , t_{off}).

- Adjustable parameters : Setpoint, proportional range and integral time. Total period of the pulse period (5 to 100 s)

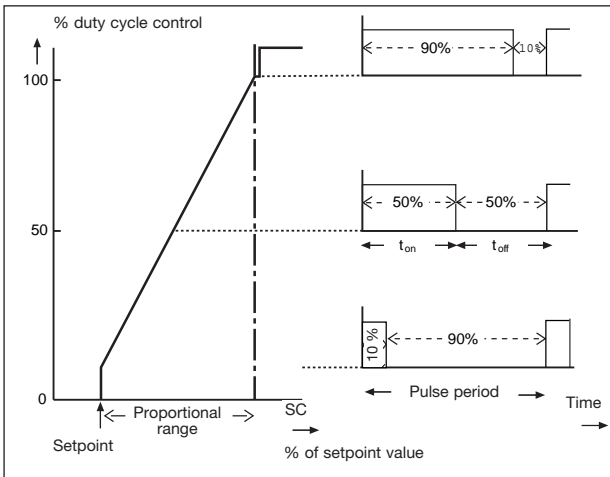

Duty cycle control

Fault alarm : Contact S4 by default set to function as an alarm, indicating that the EXA has found a fault in the measuring loop. If the self diagnostics of the EXA indicate a fault or error, the FAIL contact will be switched. In most cases this will be caused by a malfunction of the measuring loop. The FAIL contact is also closed when the power is removed. The "FAIL" contact may also be configured as a fourth process alarm.

PI pulse frequency control : The contact is used to control a pulse-driven dosing pump. The frequency of pulses regulates the pump speed.

- Adjustable parameters : Setpoint, proportional range & integral time.
Maximum pulse frequency (50 to 120/min.)

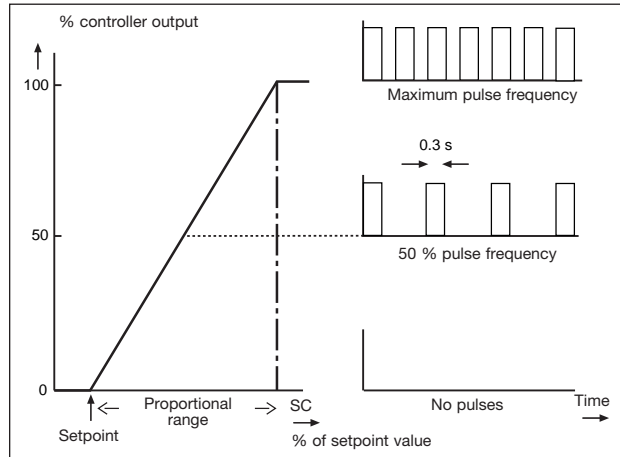

Pulse frequency control

CABLES AND TERMINALS

The SC402G is equipped with terminals suitable for the connection of finished cables in the size range of 0.13 to 2.5 mm² (26 to 14 AWG).

The glands will form a tight seal on cables of outside diameter in the range 7 to 12 mm (⁹/₃₂" to ¹⁵/₃₂").

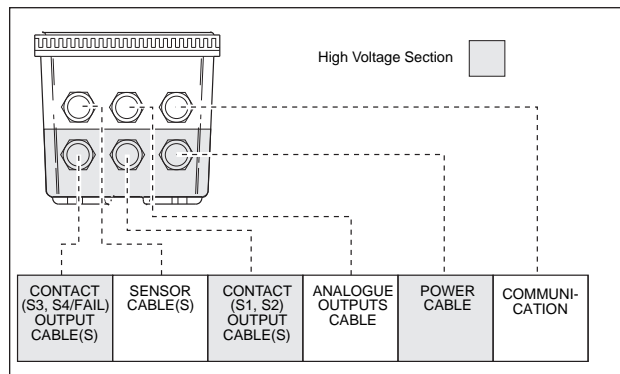

Glands to be used for cabling

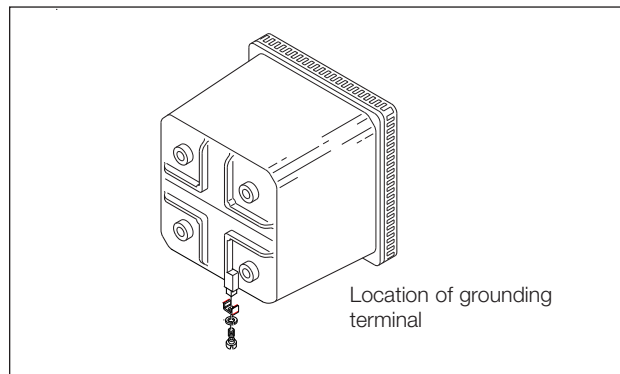

Grounding

SYSTEM CONFIGURATION

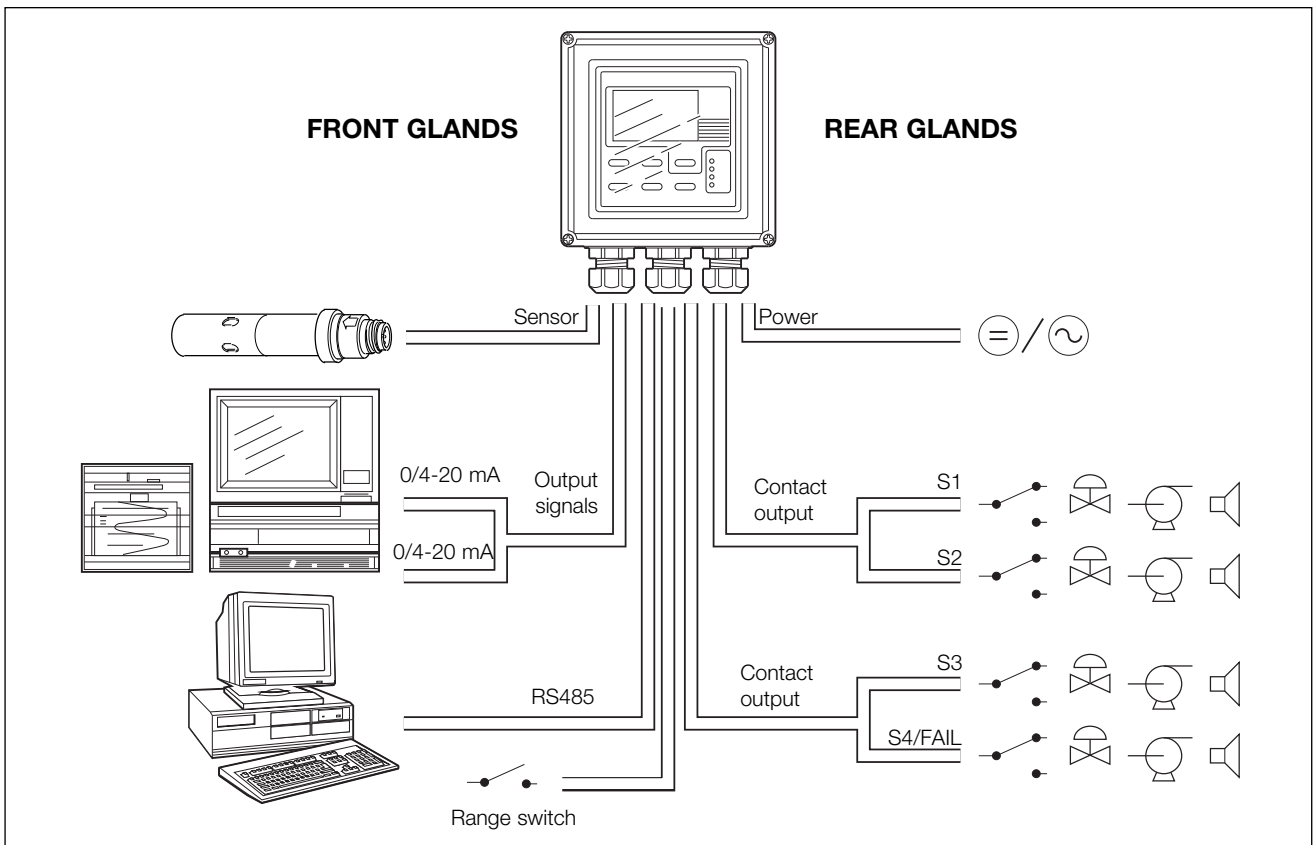

INPUT AND OUTPUT CONNECTIONS

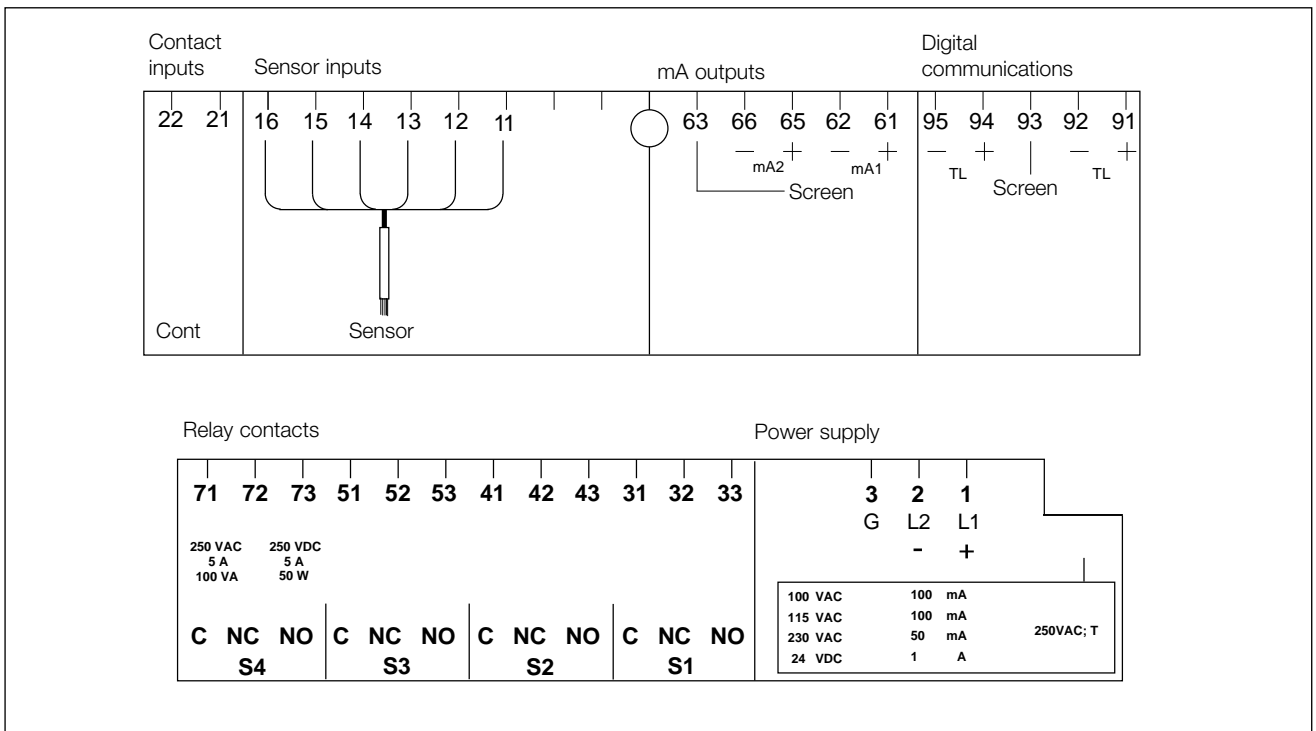

DIMENSIONS AND MOUNTING

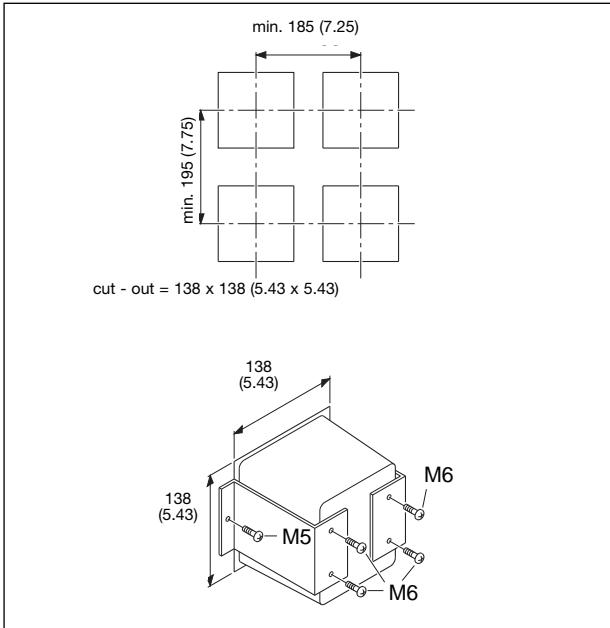



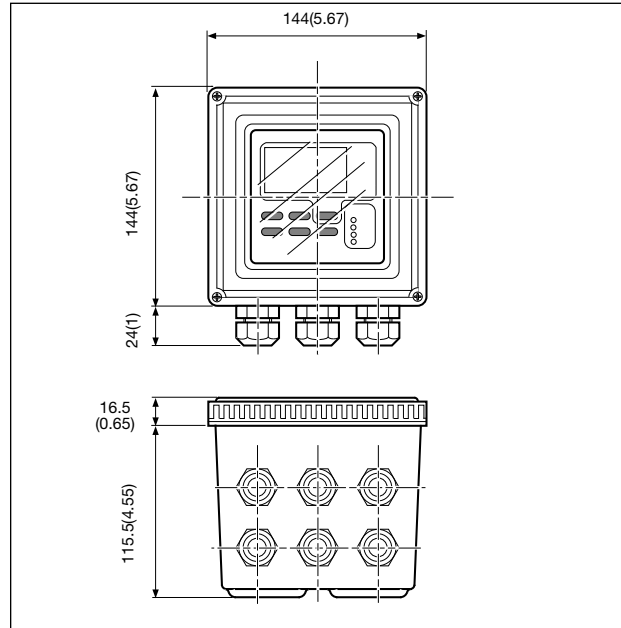

Panel cut-out, spacing and mounting

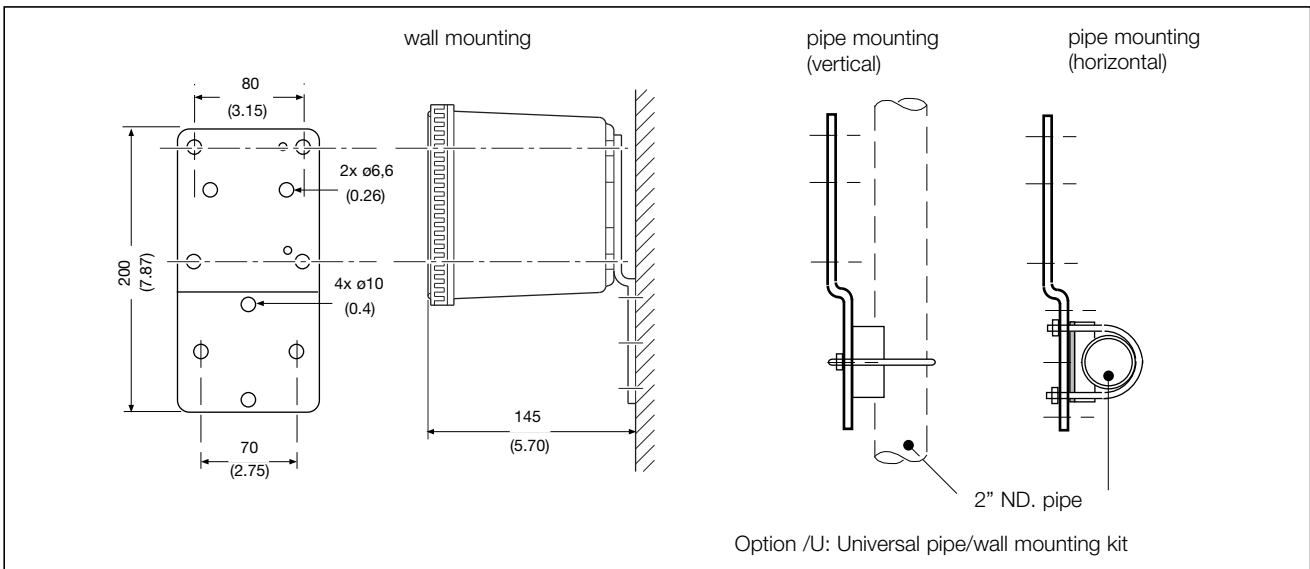

Dimensions



Universal pipe/wall mounting

| | | | | |
|--|--|--|--|---|
| <p>YOKOGAWA </p> <p></p> | | <p>GERMANY Yokogawa Deutschland GmbH Berliner Strasse 101-103 D-40880 RATINGEN Tel. +49-2102-4983 0 Fax +49-2102-4983 22</p> | <p>AUSTRALIA Yokogawa Australia Pty Ltd. Private mail bag 24 Centre Court D3 25-27 Paul Street North NORTH RYDE, N.S.W. 2113 Tel. +61-2-805 0699 Fax +61-2-888 1844</p> | <p>UNITED STATES OF AMERICA Yokogawa Industrial Automation 4 Dart Road NEWNAN, GA 30265-1040 Tel. +1-770-254 0400 Fax +1-770-251 6427</p> |
| <p>EUROPEAN HEADQUARTERS Yokogawa Europe B.V. Vanadiumweg 11 3812 PX AMERSFOORT The Netherlands Tel. +31-33-4641 611 Fax +31-33-4641 610 E-mail: info@yokogawa.nl</p> | <p>AUSTRIA Yokogawa Austria Ges.m.b.H. Franzensbrückenstrasse 26 A-1021 WIEN Tel. +43-1-216 50 43 Fax +43-1-216 50 43 33</p> | <p>ITALY Yokogawa Italia S.r.l. Vicolo D. Pantaleoni, 4 20161 MILANO Tel. +39-2-66 24 11 Fax +39-2-645 57 02</p> | <p>SINGAPORE Yokogawa Engineering Asia Pte. Ltd. 11, Tampines Street 92 SINGAPORE, 528872 Tel. +65-783 9537 Fax +65-786 2606</p> | <p></p> |
| <p>THE NETHERLANDS Yokogawa Nederland B.V. Computerweg 1, 3606 AV MAARSSEN Tel. +31-346-59 12 11 Fax +31-346-56 61 96</p> | <p>BELGIUM Yokogawa Belgium N.V./S.A. Minervastraat 16 1930 ZAVENTEM Tel. +32-2-719 55 11 Fax +32-2-725 34 99</p> | <p>SPAIN Yokogawa España S.A. C/Francisco Remiro, N°2, Edif. H 28028 MADRID Tel. +34-1-724 20 80 Fax +34-1-355 31 40</p> | <p>JAPAN Yokogawa Electric Corporation 2-9-32, Nakacho, Musashino-shi TOKYO, 180 Tel. +81-422 52 5617 Fax +81-422 52 0622</p> | <p>CENTRAL/EAST REGION Via Yokogawa Austria: Czechia, Slovakia, Hungary, Poland, Croatia, Slovenia, Jugoslavia, Bulgaria, Romania, Macedonia, Bosnia & Herzegovina</p> |
| <p>FRANCE Yokogawa Contrôle Bailey S.A. Vélizy Valley 18-20 Rue Grange Dame Rose 78140 VELIZY VILLACOUBLAY Tel. +33-1-39 26 10 00 Fax +33-1-39 26 10 30</p> | <p>UNITED KINGDOM Yokogawa United Kingdom Ltd. Stuart Road, Manor Park, RUNCORN Cheshire WA7 1TR Tel. +44-1-928 597100 Fax +44-1-928 597101</p> | <p>SOUTH AFRICA Yokogawa South Africa (Pty) Ltd. 67 Port Road, Robertsham Southdale 2135, JOHANNESBURG Tel. +27-11-680-5420 Fax +27-11-680-2922</p> | <p>Distributors in: Denmark, Finland, Greece, Norway, Portugal, Russian Federation, Sweden, Switzerland and Turkey.</p> | <p></p> |