

General Specifications

Models SSS7700,
SSS7710, SSS7720
Plant Resource Manager



GS 33Y05Q10-31E

■ GENERAL

Field networks have been developed in recent years, and field devices have become more intelligent. Now that the bidirectional all-digital FOUNDATION Fieldbus has been standardized, the era of digital communications is here. Yokogawa offers field devices as well as systems which support the FOUNDATION Fieldbus. This Plant Resource Manager Package for the fieldbus era efficiently handles field device management and maintenance work, which helps reduce Total Cost of Ownership (TCO) in your plant.

This tool also can support conventional analog devices; it can provide integrated management of both analog and FOUNDATION Fieldbus devices.

PRM R2.01 or later version supports HART devices.

■ FUNCTION SPECIFICATIONS

Plant Resource Manager (PRM) consists of the following three components:

● PRM Server

- Uses the popular, industrial-strength Oracle 8i database.
- Maintains a historical record of device parameters and maintenance records.
- Implements centralized management of device management information such as the device list, inspection record and schedule, and parts lists.
- Automatically acquires device events (e.g. alarms) on a continuous basis, twenty-four hours per day, and saves them in the database. Thus you can continuously monitor the operating status of field devices.

● PRM Client

- User-friendly Windows-based operating environment, with Explorer-like "Navigator" for selecting a specific device.
- Uses bidirectional, all-digital field networks such as FOUNDATION Fieldbus. Performs automatic device recognition and registration (Plug and Play), monitors device status, display device events (e.g. alarms), allows tuning of device parameters, and performs device diagnosis (Methods).
- Display color of device icon changes depending on device status. This provides an easy-to-understand overview of device operating status.
- Allows not merely FOUNDATION fieldbus-compliant devices but also conventional analog field devices to be registered together for true, centralized device management.

● Field Communications Server

Provides open interface functions of OLE for Process Control (OPC) that enable general-purpose software running on Windows 2000 to access field device data. Thus field data can be used in operation support applications such as device diagnostics and equipment diagnostics, and in data processing applications such as optimization.

SYSTEM CONFIGURATION

A single database server is the unit for management (e.g. for search operations). At least one field communications server is required for a CENTUM CS 1000/CENTUM CS 3000 project.

System Configuration When Connecting FOUNDATION Fieldbus

Large-scale CENTUM CS 3000

This section shows a large-scale system configuration for Plant Resource Manager.

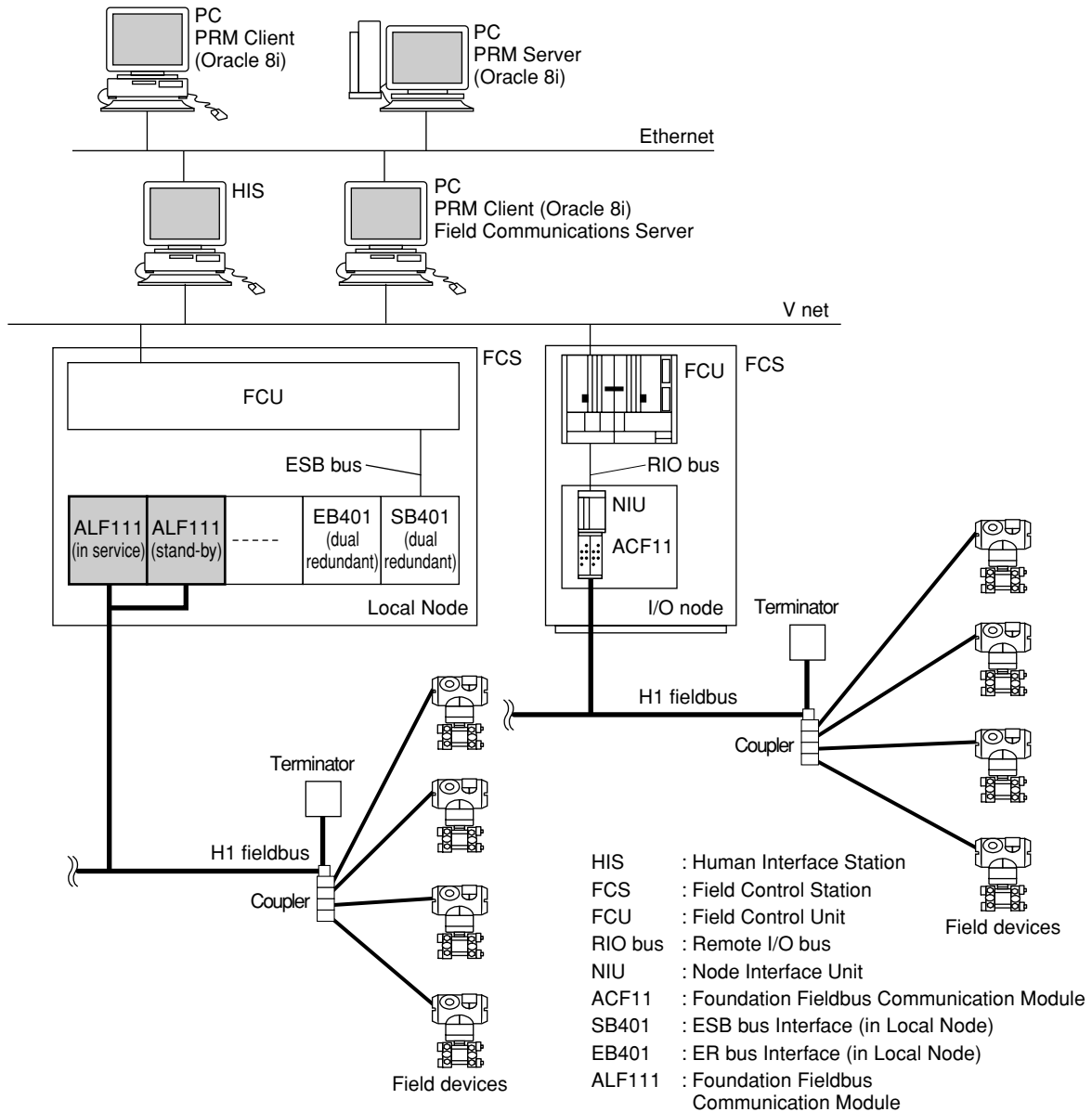

F01E.EPS

Figure: System Configuration (Large scale CENTUM CS 3000 system)

Small-scale CENTUM CS 1000

This section shows a small-scale system configuration for Plant Resource Manager.

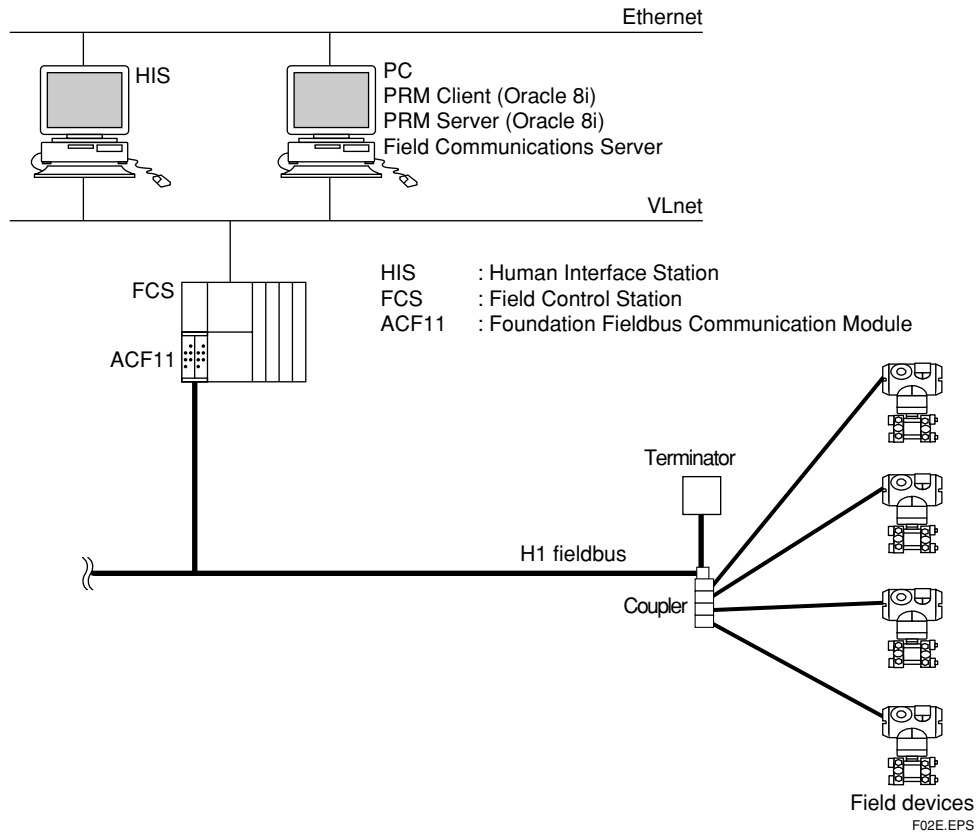

Figure: System Configuration (Small scale CENTUM CS 1000 system)

● **System Configuration When Connecting HART**

Two system configurations are available for managing HART devices as below:

- Vnet connection via HART Modules
- Serial port connection via Multiplexer

V net connection via HART Modules (FCS for FIO)

Field communication server communicates with HART devices via HART modules by using the on-demand communication functions of FCS.

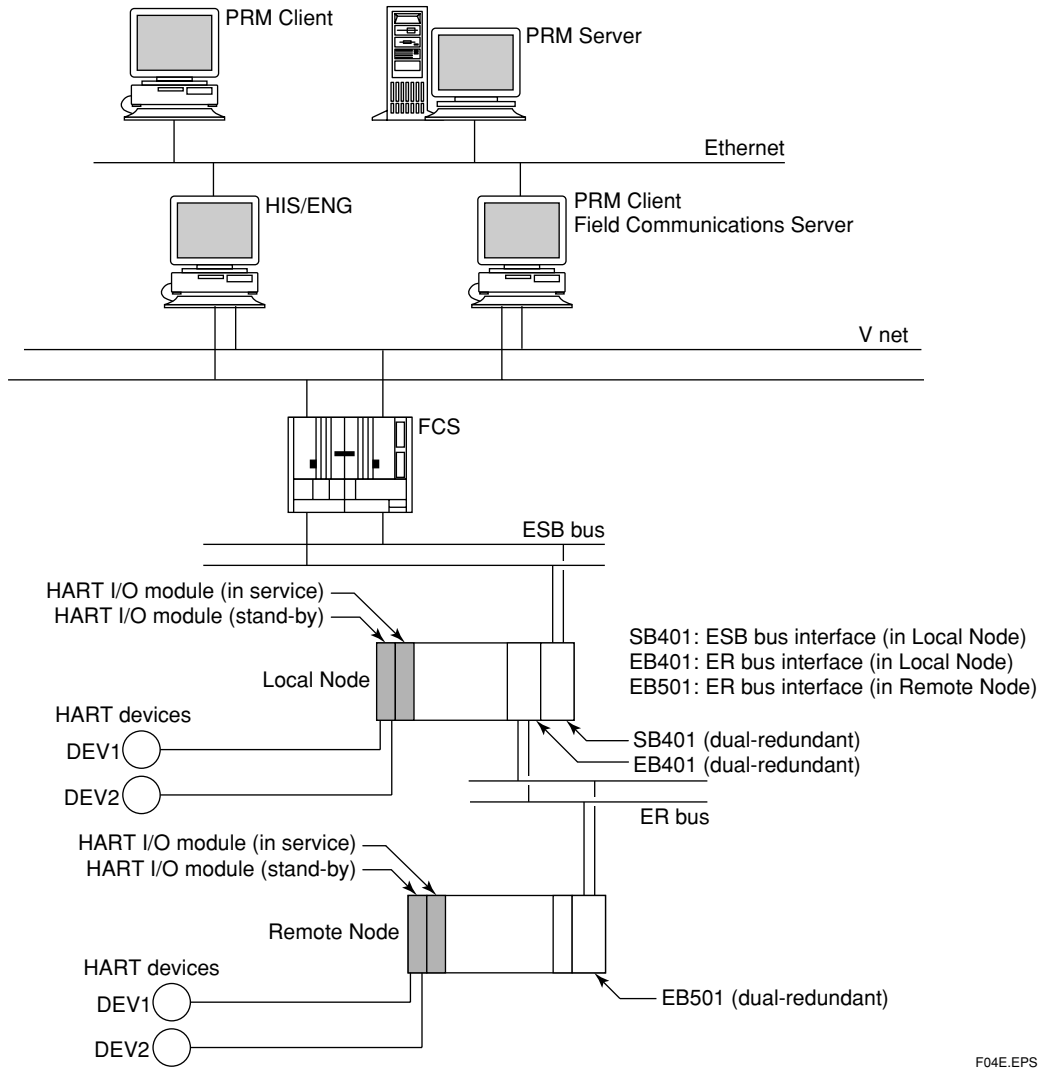

F04E.EPS

Figure V net Connection via HART Modules (FCS for FIO)

Note: PRM server, PRM client, and Field communication server can perform on the same PC.

Serial port connection via Multiplexer (FCS for RIO)

LFCS (SFCS) communicates with HART devices via Multiplexer connected with serial port of Field communication server.

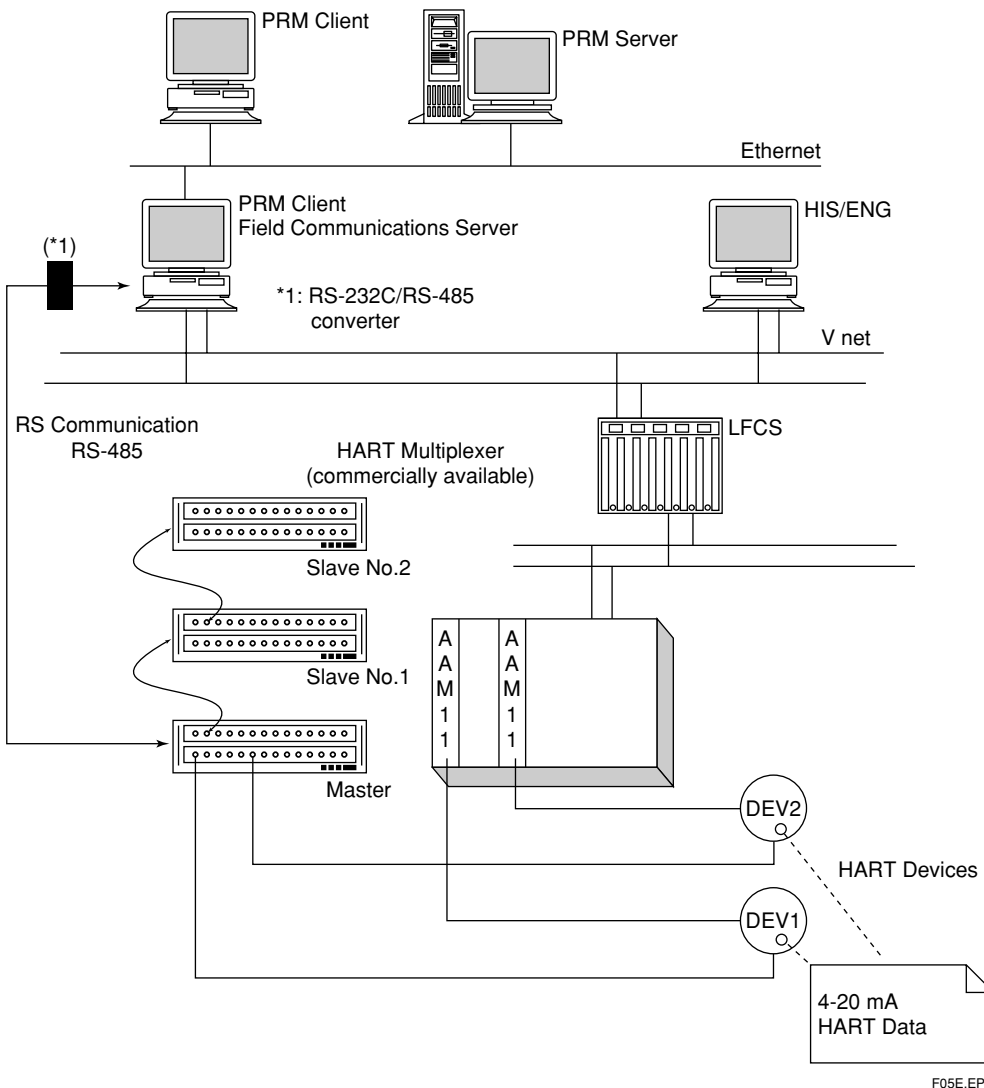
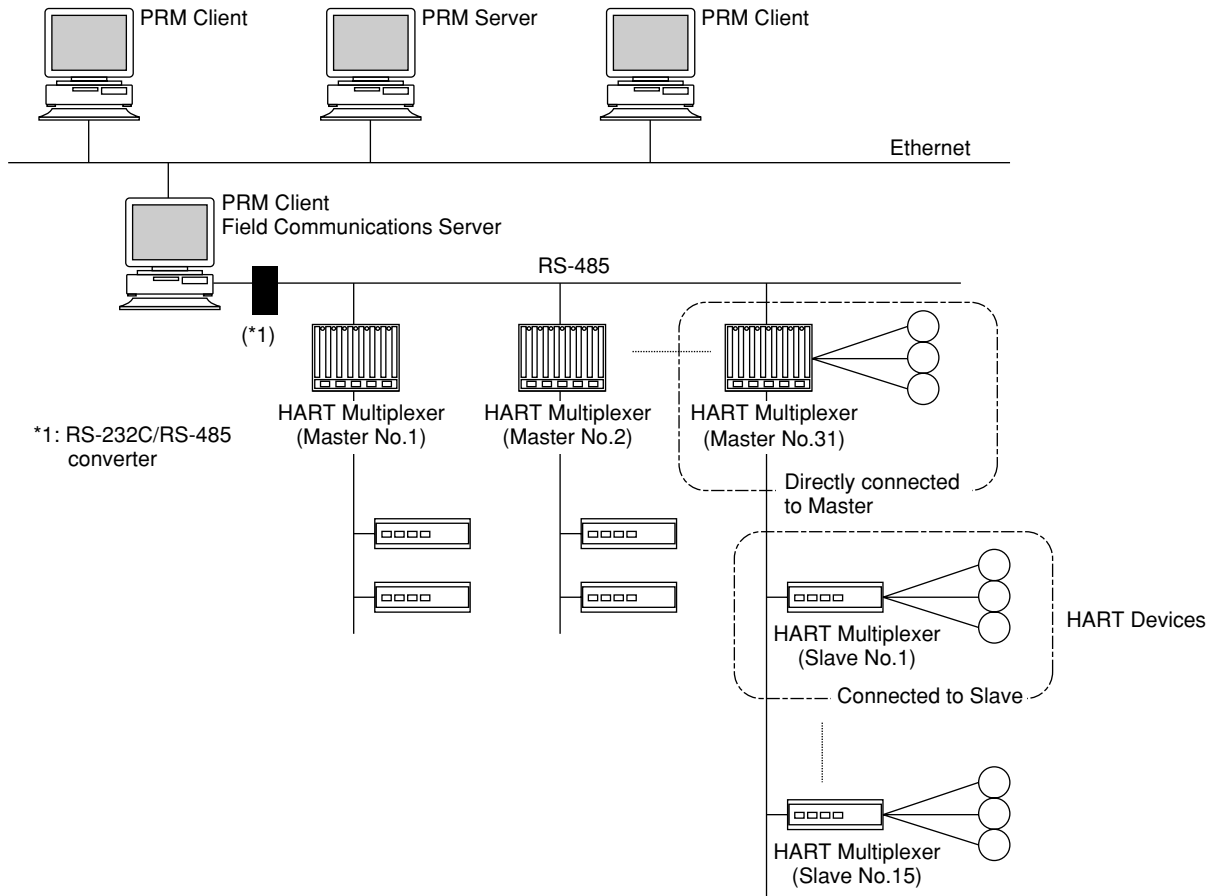

Figure Serial Port Connection via Multiplexer (Parallel Connection and Two Ways Data Flow)

Note: PRM server, PRM client, and Field communication server can perform on the same PC.

Serial port connection via Multiplexer (For using P&F Multiplexer)

When using P&F Multiplexer, can connect as follows without connecting CENTUM system.



F06E.EPS

Figure An Example of P&F Multiplexer Connection

Note: PRM server, PRM client, and Field communication server can perform on the same PC.

FUNCTION SPECIFICATIONS

● Organization of Functions

The following figure shows organization of functions.

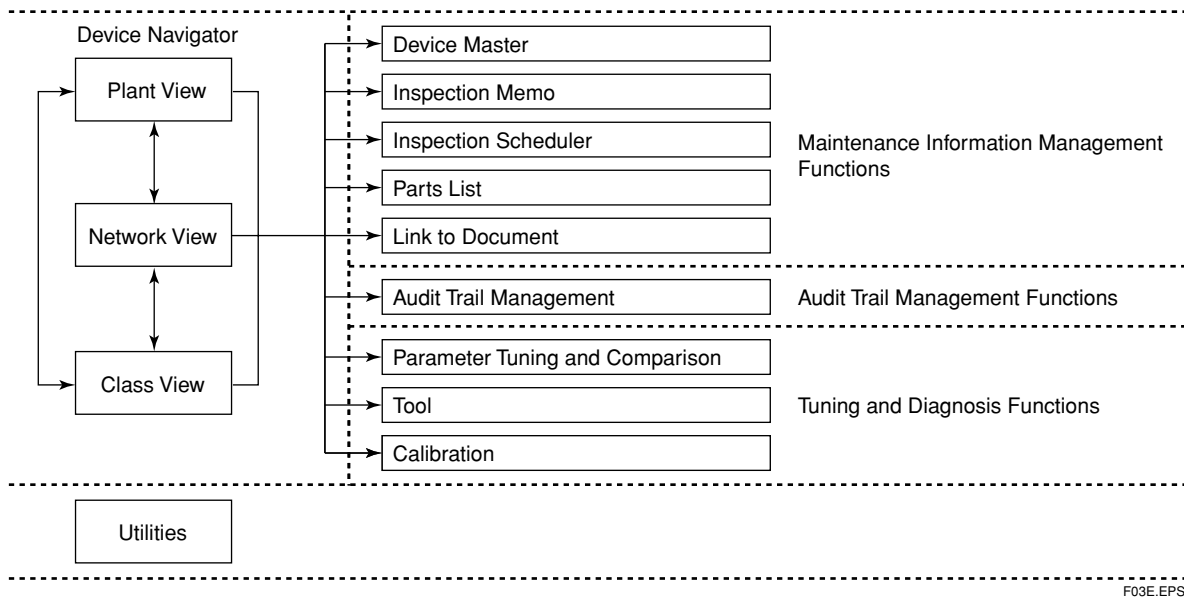

Figure: Organization of Functions

● Device Navigator

The Device Navigator provides Plant View, Network View, and Class View.

Each view displays arrangement of devices in the plant – and physical network configuration – by device type, in hierarchical Explorer-like format. You can select devices and perform plant management functions in these views.

Plant View

Displays the equipment which makes up the plant, and shows its place in the plant hierarchy, in hierarchical Explorer-like format. You can manage plant organization intuitively, based on P & ID diagrams. Unused devices in the plant can be managed by putting them in the “Spare” Folder, and devices which have failed or are under maintenance can be placed in the “Off-Service” (Out of Service) Folder.

Network View

Displays position of device, related to field network physical configuration, in an Explorer-like hierarchical view. The device icon next to the device name shows the operating status of the device – the color of the device icon changes if the device fails, so users have an immediate visual view of operating status.

Class View

Displays devices in an Explorer-like hierarchical view – grouped by supplier, model, and revision. For devices which have failed or are under maintenance, you can check the (e.g. spares) status of devices of the same type at a glance.

● Maintenance Information Management

Manages the maintenance information of all devices.

Device Master

Manages an inventory of all devices. You can display a list of all devices, or detailed information on a single device.

Inspection Memo

Maintains historical records of device inspection memo, and malfunctions. Moreover, maintenance personnel can save notes about how a failure was handled, as well as warnings or reminders about maintenance check items, in the historical record. This function can be used to manage not only device online work records but also device offline work records.

Inspection Scheduler

Manages inspection schedules (checking, tuning, calibration, etc.) for each device.

Parts List

A device may consist of several parts; the parts list displays attributes of each part, and stock information. Enhances efficiency of repair and parts replacement work.

Link to Document

This can display information such as configuration (e.g. P & ID and control drawings), exploded views, online manuals, and graphics, as desired. You can access and display this device-related information using the tag name as a key.

● Audit Trail Management

This keeps a database containing an operation history for devices (parameter setting, parameter data saving, calibration history, inspection memo history), and historical device event messages. Database contents can be displayed in chronological order or by historical message type, in summary or detailed format. You can filter operation records by device ID or device tag name, so can easily display the operation record for a specific device.

● Tuning and Diagnosis Functions

Supports device online tuning and diagnostic functions.

Parameter Tuning and Comparison

Online display and setting of device data. Compares stored device historical records with current device data. Facilitates safe switching of device operating conditions, and resetting to past values, while comparing current and past values – for safety. Can upload device data at any time, and store it in the database.

Calibration

Can execute vendor-specific calibration tool as helper package. Consistent interface to devices from different vendors.

Tool

- For FOUNDATION Fieldbus

Can move to Device Method Window

Device Method:

Using the Method of DD files provided by a vendor enables to perform Tuning and Diagnosis. The specifications are dependent on field devices.

- For HART

HART Devices Maintenance Tool is equivalent to HART Handheld Terminal. Can move to Menu and Offline Parameter Windows.

Menu Window:

Construct and execute the items of Menu in HART DD. Refer/set parameters or execute Method. Record Start/Stop of only this window as operation messages. The executed result of this window is not recorded in the database or the operation message.

Offline Parameters Window:

List and display "Offline Parameters" or "Upload Variables" described in HART DD. Change the parameter values. Record Start/Stop of only this window as operation messages. Specify a file in each device and save the parameter values; read the parameter values from the files.

Will not be archived the saved parameter values in Oracle database. The executed result of this window is not recorded in the database or the operation message.

● Utilities

Browser

Can search for devices using device attribute information such as device ID, device tag name, device tag comment, block name, or parameter value.

Security

During maintenance of field devices, restricts operation to specific user(s) – or restricts range of operations permitted – to prevent system trouble due to operator errors, and to maintain system security.

The user name and operation record of the logged-in operator is recorded in the operation history. User Group can be used to assign user privileges to groups of users (i.e. restrict rights) according to job function.

Export

Can output a list of all devices (such as device ID, device tag, and device tag comment) stored in the database or an operation history, to a text file in CSV format. You can use information managed with PRM on facility management software and the like.

Self-documentation

Automatically creates device documentation for management. Can collectively print out data stored in the database in report format. Device information is managed electronically, and can be printed out on demand. Information on each screen can be printed out as individual reports, so a report can be printed out after maintenance work to provide a maintenance work record. The following print properties can be edited:

- Printing range
- Table of contents
- Header/footer
- Cover page

Helper Package

Activates a device vendor supplied tool, such as a calibration or self-diagnosis tool, as a helper package. Consistent interface to devices from different vendors.

Online Manual (R2.02 or later)

From R2.02, all instruction manuals are provided in PDF format on CD-ROM. This enables to view and print the electronic instruction manual on-demand.

OPC Interface

Provides OPC interface for device data. Windows NT based application software can access online device data for device diagnosis or facility diagnosis.

● Supported Functions

All functions can be performed for FOUNDATION Fieldbus devices, but there are some restrictions for HART devices.

Table Supported Functions

Function		Conventional Devices(*1)	FF-H1	HART	Specification Remarks
Device Navigation Function	Plant View	○	○	○	
	Network View	–	○	○	
	Class View	○	○	○	
Maintenance Information Management Functions	Device Master	○	○	○	HART device's 'Detail' part is different from other devices.
	Plug_&_Play	–	○	○	
	Register from Host_File_Set	–	○	–	
	Inspection Memo	○	○	○	
	Inspection Schedule	○	○	○	
	Parts List	○	○	○	
	Link To Document	○	○	○	
Audit Trail Management Function	Parameter History	–	○	×	
	Inspection Memo History	○	○	○	
	Operation History	○	○	△	Record the Start/Stop of only Menu Window
	Device Event Message	–	○	○	
Tuning and Diagnosis	Parameter Comparison	–	○	×	
	Status Display	–	○	○	Take several ten seconds until this function is executed because of the performance of HART communications.
	Tool	–	○	○	Device Method for Fieldbus Menu and Offline Parameters for HART. The parameter information of HART devices can be acquired by Offline Parameters. The acquired data can be saved in each device in Text format.
	Calibration	–	○	○	
Utility	Browse Function	○	○	○	
	Security	○	○	○	
	Print Function	○	○	○	
	OPC Interface	–	○	△	Support only Plug_&_Play and Operation Status Display
	Helper Package Connection	–	○	○	

○: Supported △: Partly supported ×: Not supported –: Not applicable

T05E.EPS

*1: The conventional device includes the 4 to 20 mA analog devices and the static devices as a motor.

■ OPERATING ENVIRONMENT

● Hardware Requirements

PRM Server

IBM PC/AT-compatible
Main memory: 128 MB or greater, 256 MB or greater recommended.
Disk capacity: 4 GB or greater total disk space (at least 2 GB must be free.)
Other requirements:
DAT device, MO device (for backup).
Ethernet card

PRM Client

IBM PC/AT-compatible
Main memory: 64 MB or greater, 128 MB or greater recommended.
Disk capacity: 1 GB or greater total disk space (at least 200 MB must be free.)
Other requirement: Ethernet card

Field Communications Server

IBM PC/AT-compatible Pentium 300 MHz or higher
Main memory: 64 MB or greater, 128 MB or greater recommended.
Disk capacity: 1 GB or greater total disk space (at least 200 MB must be free.)
Other requirements: VF701 card, Ethernet card
When using P&F Multiplexer:
Multiplexer (Master): KFD2-HMM-16 (P&F)
Multiplexer (Slave): KFD0-HMS-16 (P&F)
Cable (connecting Master or Slave to terminal block):
K-HM 26 (P&F)
Cable (connecting Master to Slave): K-HM 14 (P&F)
Terminal Block: FI-**-PFH-Y... (** is specified depending on user's need) (P&F)
Power Supply: KFD2-EB2 (P&F)
Power Rail (an equipment to be used for fixing Multiplexer to a terminal board)
RS232C/RS485 Converter: IC108A (BLACK BOX)
Cable (connecting Master to converter):
Twisted pair cable (category 5)
Cable (connecting converter to PC):
EVNBMC (BLACK BOX)
DB25 male – DB9 female (inch screw thread), Straght connection

When installing PRM Server, Field Communication Server, and PRM Client in one PC:

IBM PC/AT-compatible: Pentium 300 MHz or higher (Pentium III 1 GHz or higher recommended)
Main memory: 256 MB or greater, 512 MB or greater recommended
Disk capacity: 3 GB or greater must be free

● Software Requirements

PRM Server

OS: Windows 2000 (Professional) Service Pack 1, 2
Internet Explorer 5.0 or later
Oracle 8i: Oracle Database R8.1.6, R8.1.7

PRM Client

OS: Windows 2000 (Professional) Service Pack 1, 2
Oracle 8i: Net 8i

Field Communications Server

OS: Windows 2000 (Professional) Service Pack 1, 2
V net (CS 3000) communications driver
VL net (CS 1000) communications driver

MODELS AND SUFFIX CODES

PRM Server (for new installation)

		Description
Model	SSS7700	Plant Resource Management Server [Media model: SSSSM02-C11]
Suffix Codes	-S	Basic software license
	-C	Multiple software licenses (for 2 or more)
	1	Windows 2000
	1	English version
Option Codes	/N0100	Number of connected devices: 100 or fewer
	/N1000	Number of connected devices: 101-1000
	/N3000	Number of connected devices: 1001-3000

T01E.EPS

- Note: This package is supported by R3.01 and later.
- Note: This package cannot be installed in HIS PC. Prepare a PC separate from HIS PC.
- Note: This package uses Oracle8i for the database. Prepare Oracle8i separately from this package.
- Note: Exaopc OPC Interface Package for HIS is required to acquire device events.

PRM Server (for expansion)

		Description
Model	SSS7700	Plant Resource Management Server [Media model: SSSSM02-C11]
Suffix Codes	-A	Software license for additional devices
	1	Windows 2000
	1	English version
Option Codes	/N0110	Change number of connected devices: "100 or fewer" to "101-1000"
	/N0130	Change number of connected devices: "100 or fewer" to "1001-3000"
	/N1030	Change number of connected devices: "101-1000" to "1001-3000"

T02E.EPS

- Note: This package is supported by R3.01 and later.
- Note: This package cannot be installed in HIS PC. Prepare a separate PC from HIS PC.
- Note: This package uses Oracle8i for the database. Prepare Oracle8i separately from this package.
- Note: Exaopc OPC Interface Package for HIS is required to acquire device events.

PRM Client

		Description
Model	SSS7710	Plant Resource Management Client [Media model: SSSSM02-C11]
Suffix Codes	-S	Basic software license
	-C	Multiple software licenses (for 2 or more)
	1	Windows 2000
	1	English version

T03E.EPS

- Note: This package is supported by R3.01 and later.
- Note: Multiple clients can operate this application with a multiple client package of Oracle8i.

Field Communications Server

		Description
Model	SSS7720	Field Communications Server [Media model: SSSSM02-C11]
Suffix Codes	-S	Basic software license
	-C	Multiple software licenses (for 2 or more)
	1	Windows 2000
	1	English version
Option Code	/HART	For HART devices (*1)

T04E.EPS

- Note: This package is supported by R3.01 and later.
- The function for connecting with FOUNDATION Fieldbus devices is included in the basic specification.
- Note: This package cannot be installed in HIS PC. Prepare a PC separate from HIS PC.
- *1: R3.02 or later version supports this option code.
- When connecting HART devices, specify the option code '/HART'.

Any or all Plant Resource Manager (Field Communications Server, Database Server, and Client) can be installed on a single PC.

■ ORDERING INSTRUCTIONS

Specify model and suffix codes.

■ TRADEMARKS

- CENTUM is a registered trademark of Yokogawa Electric Corporation.
- Pentium is a registered trademark of Intel Corporation.
- Ethernet is a registered trademark of XEROX Corporation.
- Windows is a registered trademark of Microsoft Corporation.
- "FOUNDATION" of "FOUNDATION Fieldbus" is a registered trademark of Fieldbus Foundation.
- Adobe and Acrobat are registered trademarks of Adobe Systems Incorporated.
- Oracle is a registered trademark of Oracle Corporation.
- "HART" is a registered trademark of the HART Communication Foundation.
- Other product and company names appearing in this document are trademarks or registered trademarks of their respective holders.